

STANDARD FEATURES

1. ROTARY LOBE POSITIVE DISPLACEMENT BLOWER (ROOTS, SUTORBILT, M-D, DUROFLOW)
2. 100 HP TO 600 HP MOTOR
3. STRUCTURAL BASE WITH MOTOR SLIDE BASE FOR BELT TENSIONING
4. V-BELT DRIVE (1.5 SAFETY FACTOR) AND OSHA BELT GUARD
5. INTAKE AIR FILTER WITH WEATHER COVER AND REPLACEABLE FILTER ELEMENT
6. VERTICAL INTAKE SILENCER
7. HORIZONTAL DISCHARGE SILENCER
8. 0-30 PSI LIQUID FILLED PRESSURE GAUGE
9. DUAL SET POINT PRESSURE SWITCH
10. PRESSURE RELIEF VALVE
11. CHECK VALVE
12. ALL COMPONENTS AND FRAME ARE PAINTED EITHER CAMCORP STANDARD WHITE OR ENVIROGREEN INDUSTRIAL ENAMEL WITH THE EXCEPTION OF THE BLOWER AND MOTOR WHICH ARE THE MANUFACTURERS STANDARD PAINT

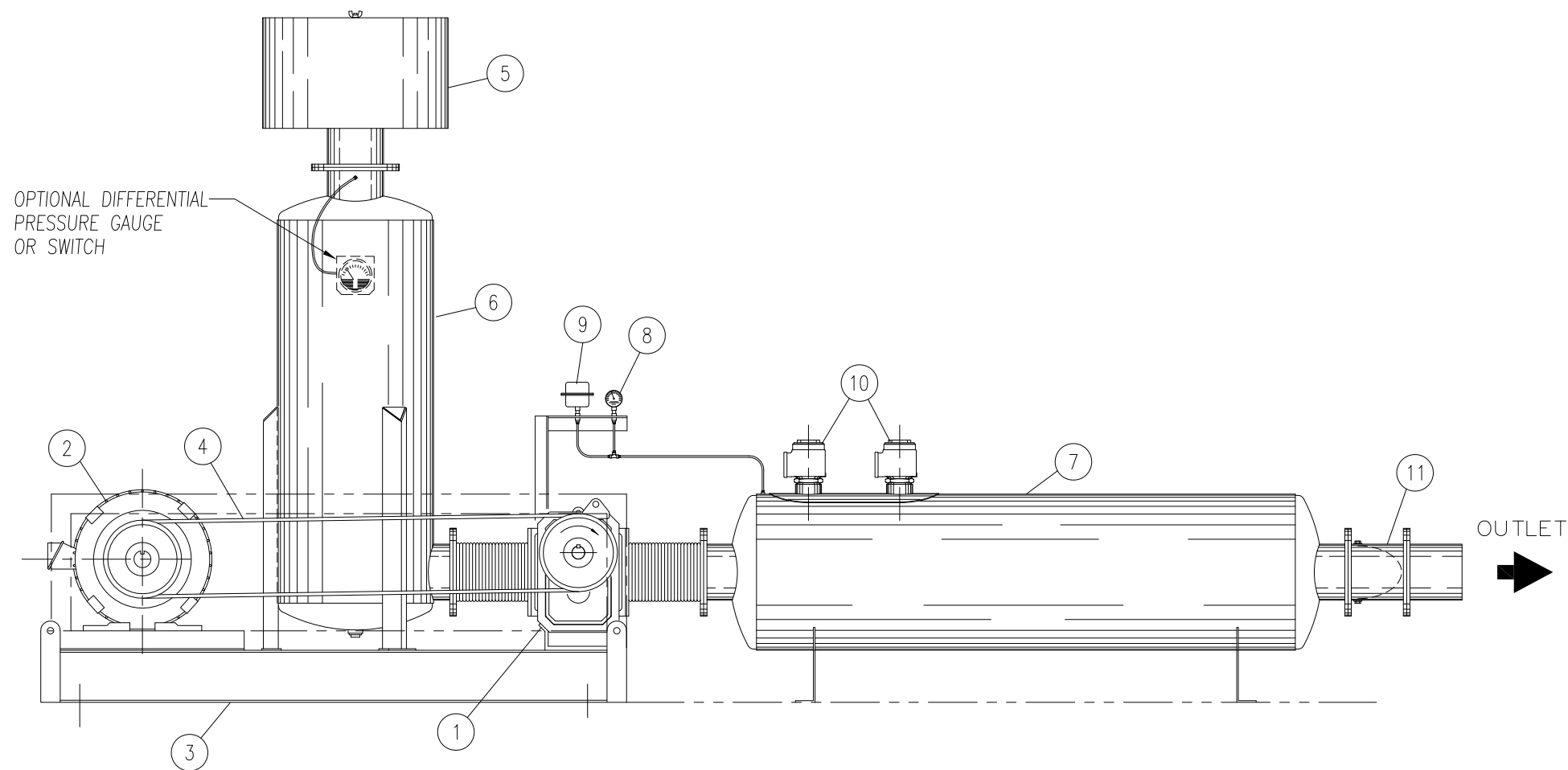

OPTIONAL FEATURES

1. DIFFERENTIAL PRESSURE SWITCH ON THE INLET FILTER
2. DIFFERENTIAL PRESSURE GAUGE ON THE INLET FILTER
3. SOUND ENCLOSURE WITH COOLING FAN AND EXTERNAL GAUGES AND INSTRUMENTS
4. TEMPERATURE GAUGE
5. TEMPERATURE SWITCH
6. WEIGHTED PRESSURE RELIEF VALVE

HORIZONTAL STYLE
PRESSURE BLOWER PACKAGE
(100 HP TO 600 HP)

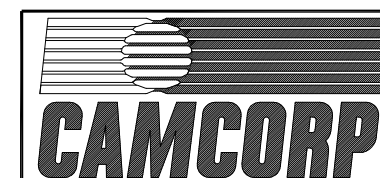

9732 PFLUMM, LENEXA, KS 66215

PHONE: 913-831-0740 • FAX: 913-831-9271

TITLE: PRESSURE BLOWER PACKAGE - HORIZONTAL (100 HP TO 600 HP)				
DATE: 08/04/99	DRN BY: DOTY	DWG. NO.: CAT-PBPHORZ	P.S.: 24-00	REV.: