

HOPPER/DISCHARGE OPTIONS PER APPLICATION REQUIREMENTS

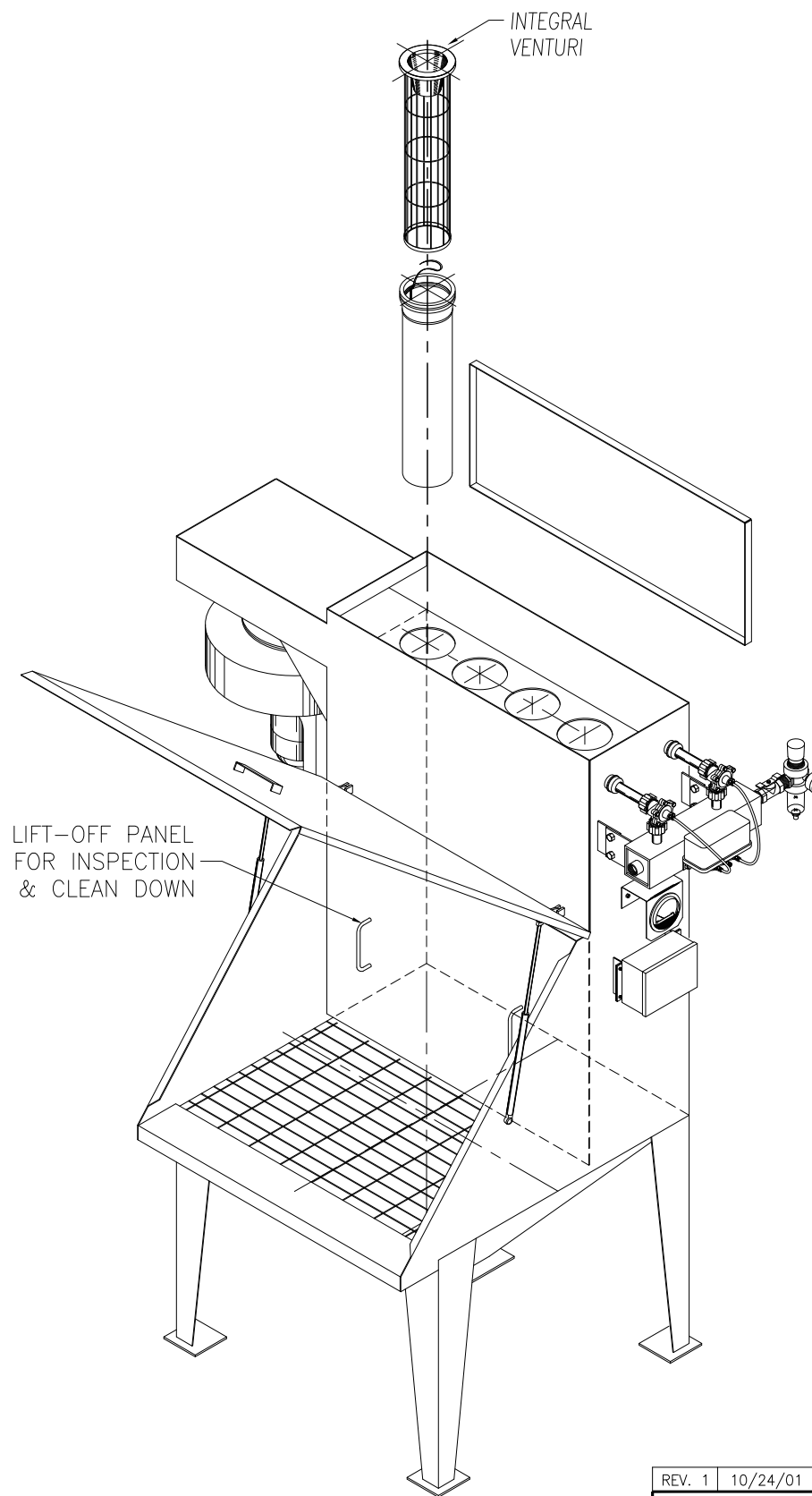
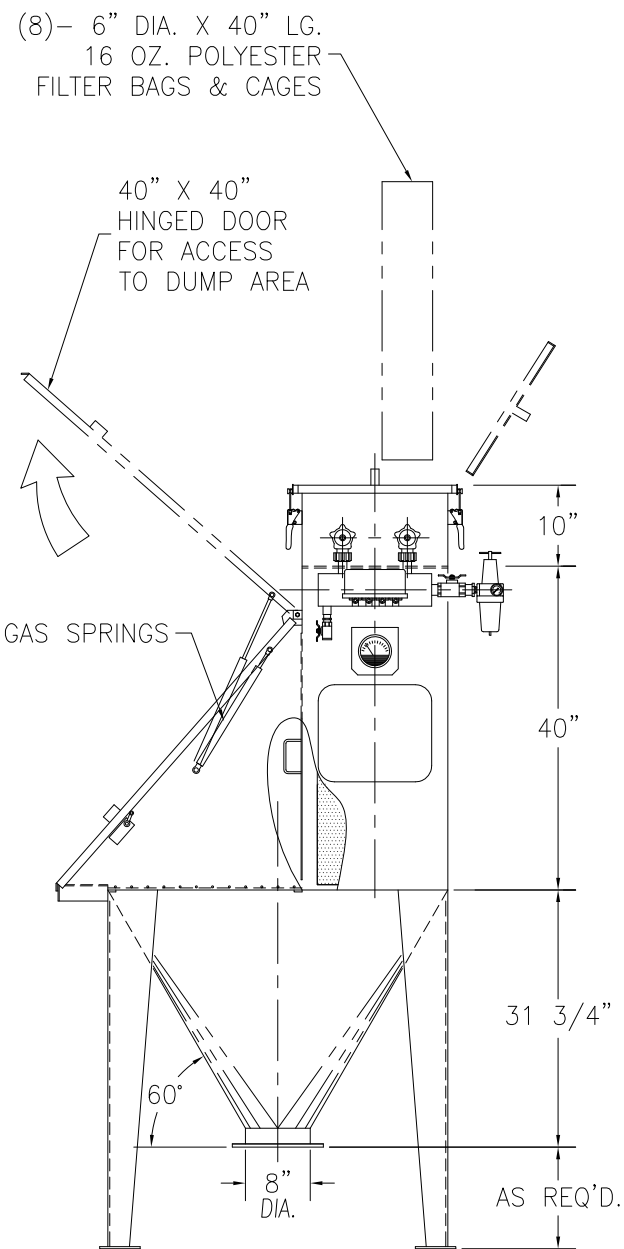

STANDARD FEATURES:

- \* SEQUENTIAL TIMER MOUNTED IN A NEMA 4 ENCLOSURE
- \* MAGNEHELIC GAUGE MOUNTED IN ENCLOSURE
- \* NO TOOL ACCESS
- \* NO TOOL REMOVAL OF FILTER ELEMENTS
- \* AIR FILTER REGULATOR W/0-100 PSIG PRESSURE GAUGE
- \* COMPRESSED AIR INLET ISOLATION VALVE
- \* 16 OZ. FELT POLYESTER FILTER BAGS WITH CAGES
- \* SIDE MOUNT FAN

OPTIONAL FEATURES:

- \* REMOVABLE MESH SCREEN
- \* VIBRATING MESH SCREEN
- \* MAGNETIC GRATE
- \* LIMIT SWITCH
- \* SWING AWAY DOOR
- \* TOP OR SIDE ACCESS TO FILTER ELEMENTS
- \* HIGH EFFICIENCY FILTER BAGS
- \* STRUCTURAL SUPPORT LEGS
- \* EXPLOSION PROOF CONTROLS
- \* MIXER OR BIN MOUNT

MODEL BD40-BSD BAG DUMP STATION

- \* FILTERED DESIGN
- \* FILTER BAGS
- \* SINGLE DOOR

REV. 1	10/24/01	ADDED NOTES			
					
<small>9732 PFLUMM, LENEXA, KS 66215</small>			<small>PHONE: 913-831-0740 • FAX: 913-831-9271</small>		
TITLE:			SINGLE HINGED ACCESS DOOR BAG FILTRATION BAG DUMP		
DATE:	DRN BY:	DWG. NO.:	P.S.:	REV.:	
09/01/99	DOTY	BAGDUMP1	24-00	#1	