

HOPPER/DISCHARGE OPTIONS PER APPLICATION REQUIREMENTS

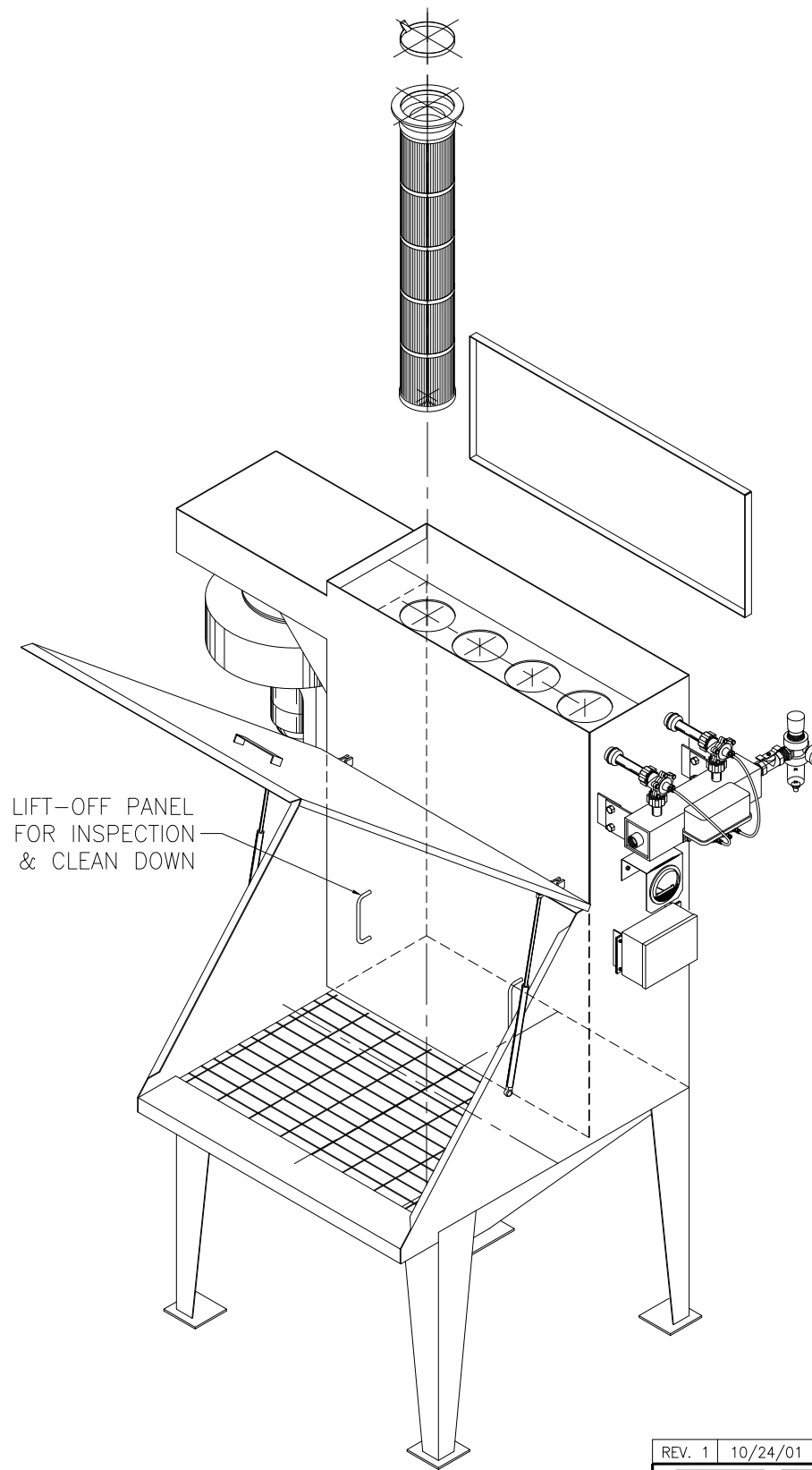
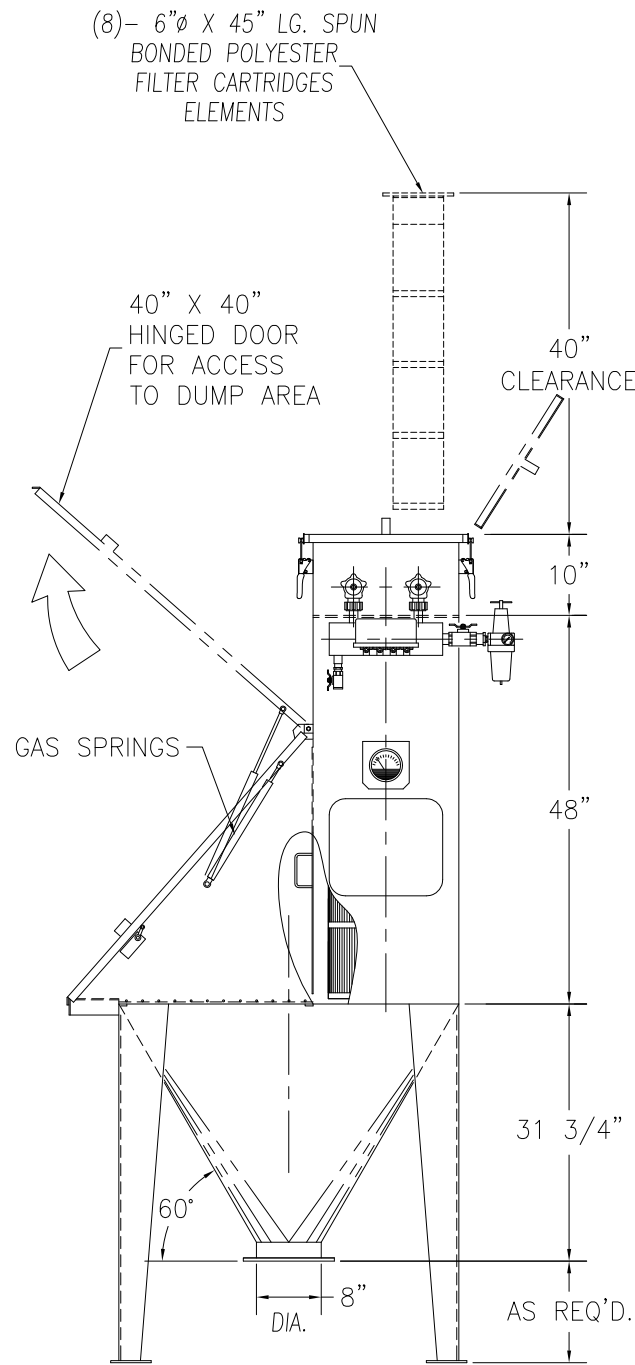

STANDARD FEATURES:

- \* SEQUENTIAL TIMER MOUNTED IN A NEMA 4 ENCLOSURE
- \* MAGNEHELIC GAUGE MOUNTED IN ENCLOSURE
- \* NO TOOL ACCESS
- \* NO TOOL REMOVAL OF FILTER ELEMENTS
- \* AIR FILTER REGULATOR W/0-100 PSIG PRESSURE GAUGE
- \* COMPRESSED AIR INLET ISOLATION VALVE
- \* SPUN BONDED POLYESTER FILTER CARTRIDGE ELEMENTS
- \* SIDE MOUNT FAN

OPTIONAL FEATURES:

- \* REMOVABLE MESH SCREEN
- \* VIBRATING MESH SCREEN
- \* MAGNETIC GRATE
- \* LIMIT SWITCH
- \* SWING AWAY DOOR
- \* TOP OR SIDE ACCESS TO FILTER ELEMENTS
- \* HIGH EFFICIENCY FILTER BAGS
- \* STRUCTURAL SUPPORT LEGS
- \* EXPLOSION PROOF CONTROLS
- \* MIXER OR BIN MOUNT

MODEL BD40-CSD BAG DUMP STATION

- \* FILTERED DESIGN
- \* FILTER CARTRIDGES
- \* SINGLE DOOR

REV. 1 10/24/01 ADDED NOTES



9732 PFLUMM, LENEXA, KS 66215

PHONE: 913-831-0740 FAX: 913-831-9271

TITLE: SINGLE HINGED ACCESS DOOR CARTRIDGE FILTRATION BAG DUMP

DATE: 04/04/01	DRN BY: DOTY	DWG. NO.: BAGDUMP5	P.S.: 24-00	REV.: #1
----------------	--------------	--------------------	-------------	----------