

Crossword puzzles can be fun if you have time to solve the puzzle. But if you need to be correct on your first selection...you need **CAMCORP**. Contact us at 1-877-**CAMCORP** for your first choice in Dust Collection & Pneumatic Conveying Systems & Components.



9732 Pflumm Road • Lenexa, KS 66215

Phone: 913- 831- 0740 • Toll Free 1- 877- 226- 2677 • Fax: 913- 831- 9271

Web Site: camcorpinc.com • E-Mail: info@camcorpinc.com

AIR POLLUTION SYSTEMS • CONSULTING SERVICE • FILTERING AND CONVEYING EQUIPMENT

REPLACEMENT PARTS, COMPONENTS & SYSTEMS

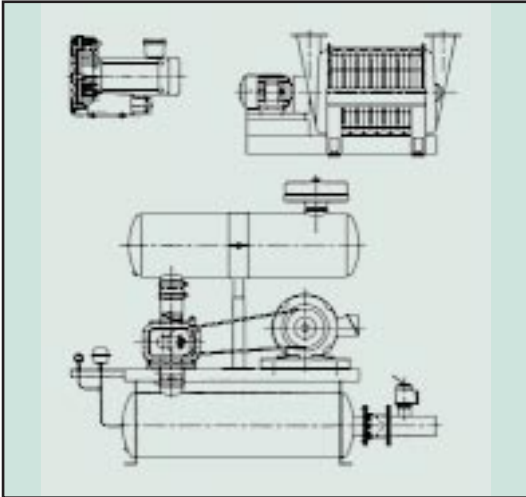

BLOWER PACKAGES

Pressure, vacuum, combination vacuum/pressure positive displacement and regenerative packages are available in a wide variety of configurations for engineered performance. All packages designed to meet your specific design needs for pneumatic conveying and aeration systems. A wide range of Blowers available including Roots, Sutorbilt, DuroFlow, Gardner Denver, M-D, Hoffman & Spencer Turbine.

Contact CAMCORP for all your blower package parts & replacements.

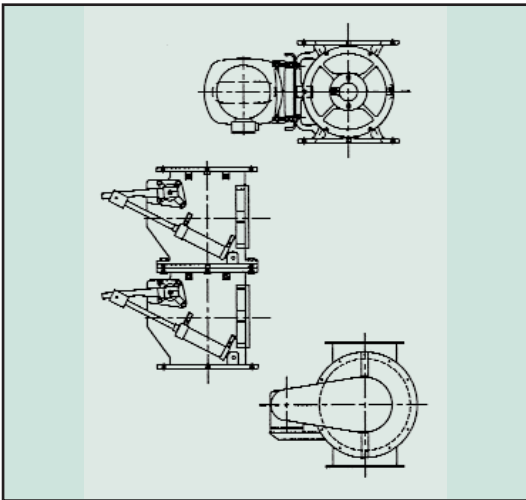

AIRLOCKS & DOUBLE DUMP VALVES

Rotary Airlocks are used to volumetric feed product. They must be suitable for gravity feed conditions and more demanding pneumatic conveying applications as not only a volumetric feeder but also as a seal against pressure or vacuum conditions. The type of valve selected will dictate the efficiency of your system.

Double Dump or Tandem Valves can be used to volumetric feed abrasive products when airlocks are not well suited due to product characteristics or temperature and to maintain critical pressure differentials without leakage.

Contact CAMCORP for all your Airlock & Double Dump Valve parts & replacements.

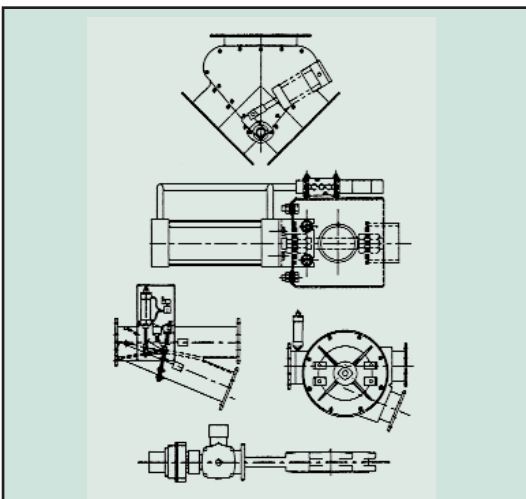

DIVERTER, KNIFE GATE AND BUTTERFLY VALVES

Diverter valves are applied when either product or air is required at multiple destinations, or needs converging into the same process line. Knife gates and Butterfly valves can be utilized as metering, shutoff, or safety valves for product and air depending on their configuration. Product and system knowledge is critical when required to select the correct and most cost effective valve for any given process application. Positive and dependable line switching and metering is critical for an "Optimized" dust collection or product transfer system.

Contact CAMCORP for all your Valve parts & replacements

REPLACEMENT PARTS, COMPONENTS & SYSTEMS

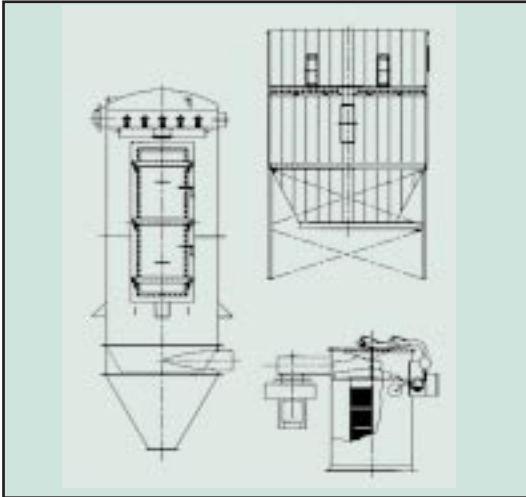

DUST FILTERS, FILTER RECEIVERS & BIN VENT FILTERS

Standard, cataloged pulse jet filters available in sizes up to 960 filters and 18,432 square feet of cloth to meet a wide variety of filtration needs. Filters available in below the tubesheet dirty air plenum removal or above the tubesheet clean air plenum or walk in plenum removal. Both cartridge filter and fabric filter technology available. Our unique BinPal in a Box bin vent filter has been designed and engineered from our customers "wish list" of Safer Working Conditions, Easy Access, Efficiency, Cost Effectiveness & Flexibility.

*Contact CAMCORP for all your
Filter parts & replacements.*

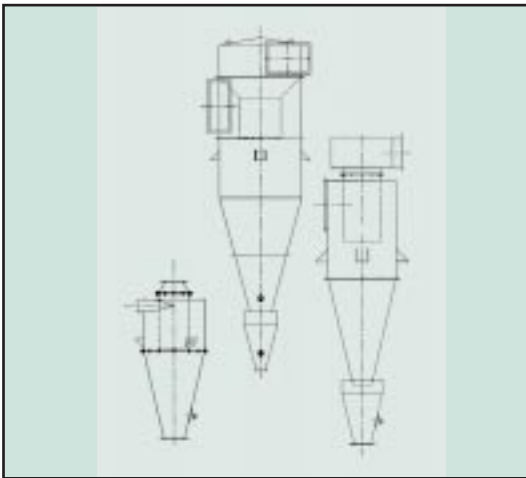

CYCLONES

Three standard series provide up to 12 ft. diameter and 71,600 CFM capability. Cyclones are available with or without disengagement chambers depending on the efficiency expectation, product and gas stream characteristics and downstream equipment. Materials of construction that are available include carbon and stainless steel, aluminum and abrasion resistant plate.

*Contact CAMCORP for all your
Cyclone replacements.*

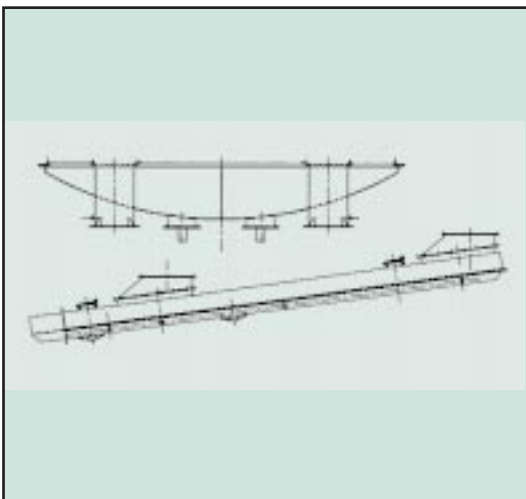

AIRSLIDE CONVEYORS & AIR DISCS

Pneumatic conveying systems are not always the best choice for moving dry bulk solids. Airslide conveyors are economical alternatives – especially when tonnage is high or the product is abrasive. An airslide is an inclined channel in which dry, solid particles will flow under the influence of gravity and aeration. The airslide offers low conveying velocity with high mass flow rates. An open top airslide trough can also be used on the slope angles of conical hoppers as an air assisted flow aid device for dry, bulk solids. Air discs are used on the flat bottom of cone hoppers as an air assisted flow aid device.

*Contact CAMCORP for all your
Airslide parts & replacements.*

REPLACEMENT PARTS, COMPONENTS & SYSTEMS

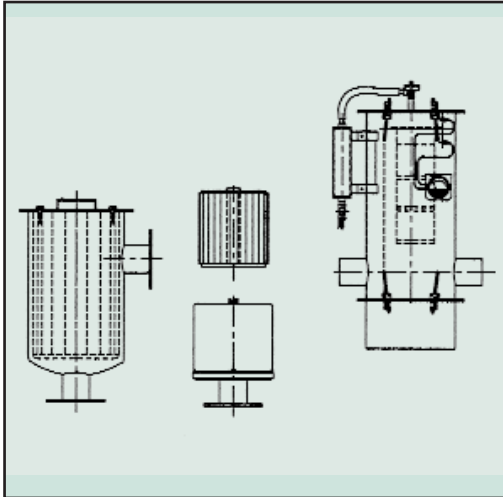

PRE-FILTERS & INTAKE FILTERS

Single cartridge filters are used to clean the air at the air intake of vacuum systems or as a pre-filter to protect close tolerance down stream equipment such as positive displacement blowers. The filters can be static or pulse jet design with or without hoppers. Replacement cellulose filters available for all makes of pressure and vacuum blower packages. Inline filters can be configured with **CAMCORP** Poly-EI pleated cartridge filter media. Filters can be equipped with a dirty filter indicator or a differential pressure gauge for maintenance scheduling.

Contact CAMCORP for your Pre-filter & Intake Filter parts & replacements.

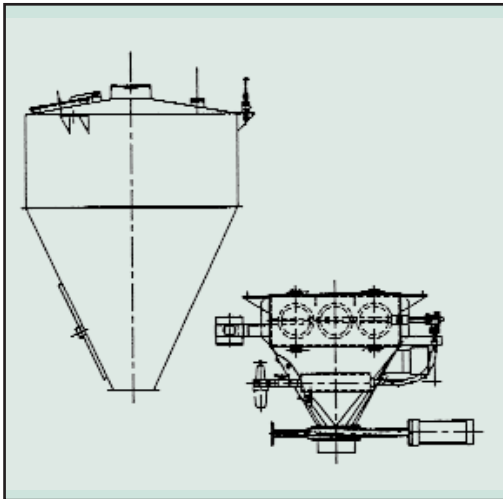

CUSTOM FABRICATION

Actual installation footprints often do not match-up with manufacturer's standard equipment dimensions. **CAMCORP** prides itself in the ability to incorporate unique designs that accommodate the needs of our customers. Low profile filters and fabricated bins, containment filters with davited heads and horizontal storage tanks are just a few of the innovative solutions we have provided to our customers. Filter retro-fits are also available for your outdated or poor performing dust filters.

Contact CAMCORP with your Custom Fabrication challenge

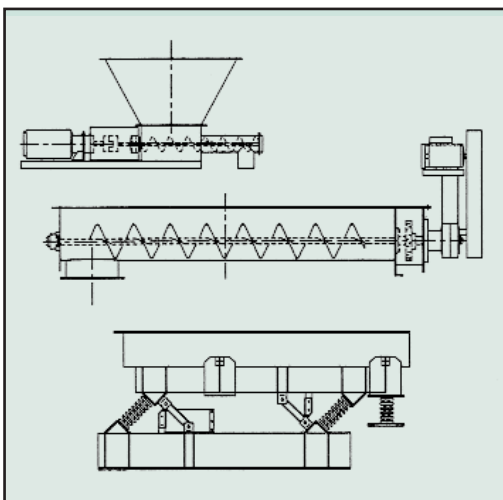

VOLUMETRIC FEEDERS & SCREW CONVEYORS

Volumetric Feeders & Screw Conveyors are integrated into **CAMCORP** systems to unload storage tanks or deliver a uniform volumetric flow of product to scales, mixers and process equipment. Precise measurement can be achieved by configuring the feeder with load cells and operating in Loss-of-Weight mode.

Contact CAMCORP for your Volumetric Feeder & Screw parts & replacements.

REPLACEMENT PARTS, COMPONENTS & SYSTEMS

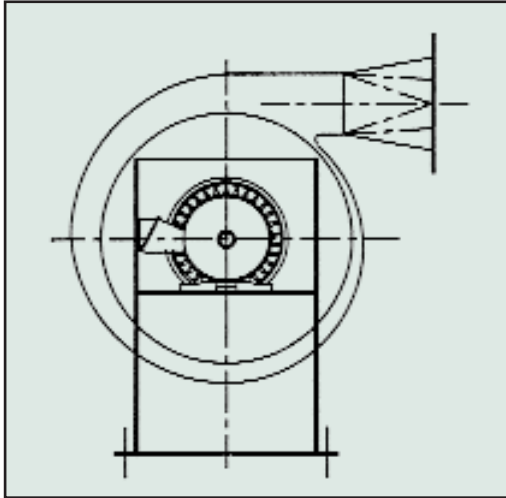

FANS

Industrial duty fans are chosen based on the design criteria of the system including total airflow requirements and pressure drop. The ductwork, hoods, collectors, process machinery and environmental conditions of your system are evaluated to help determine the selection. Typical systems include general aspiration and ventilation, dust collection and material conveying. Drives available include v-belt or direct drive. Materials of construction include stainless steel, carbon steel and aluminum. Wheel types include radial blade, backward inclined and airfoil.

Contact CAMCORP for all your Fan parts & replacements.

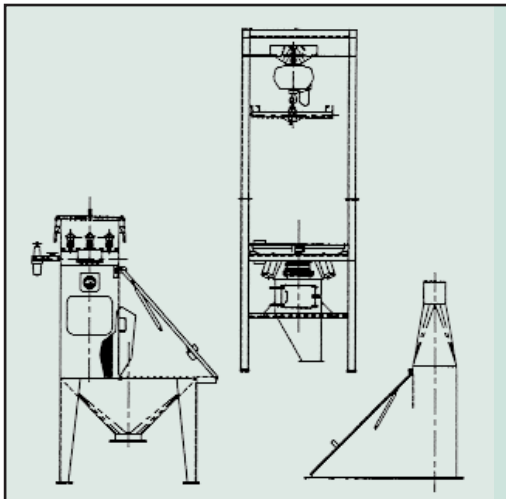

BAG DUMP STATIONS & BULK BAG UNLOADERS

Bag Dump Stations can be designed with an integral dust collection filter and fan or with a dust hood for remote central dust collection. The stations can be designed as free standing or direct mounted as a hood on mixers or surge bins. Door designs include single or dual doors that hinge up or swing to the side. The internal grate area is removable. Custom designs are available to facilitate unloading of super sacks and bags. Bulk Bag Unloaders can be configured with a monorail & hoist assembly or universal fork truck lifting carriage and frame. Integral dust collection is also available.

Contact CAMCORP for your Bag Unloading requirements.

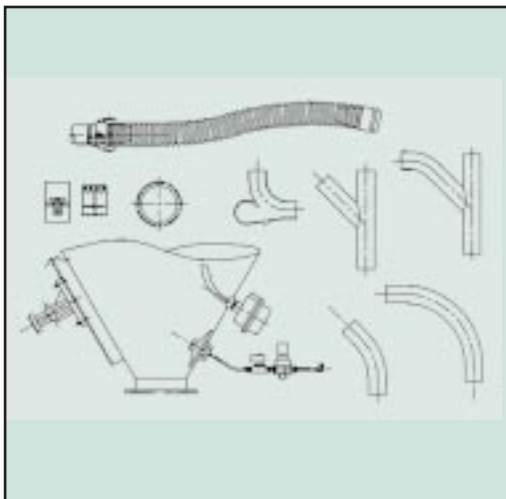

LINE COMPONENTS & HOPPER ACCESSORIES

A wide range of convey line, elbows, sight glass, couplings, flanges, adaptors, laterals, wyes, flex hose and reducers in pipe and tubing sizes are available from **CAMCORP**. We can also supply all your hopper accessories including air piston or rotary electric vibrators, air sweeps and air cannons, flo-cones and air pads, level indicators and multi-point level control & inventory systems, hinged and bolted view ports, hinged and bolted access openings, and special flow aid coatings for new hoppers.

Contact CAMCORP for your Convey Line & Hopper Accessories parts & replacements.

REPLACEMENT PARTS, COMPONENTS & SYSTEMS

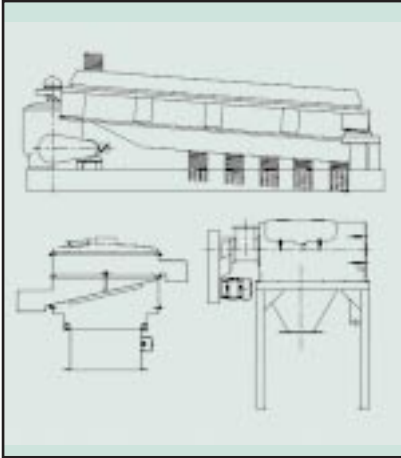

VIBRATING SCREENS & CENTRIFUGAL SIFTERS

Screeners and Sifters are integrated into **CAMCORP** systems for sizing and separation requirements. Vibrating screens are used for scalping coarse

products and sizing finer materials over single or multiple screen decks. Sifters area also used for scalping and sifting of powders and granular materials without the motion or vibration of vibrating screens.

Contact CAMCORP for your Screener & Sifter parts & replacements.

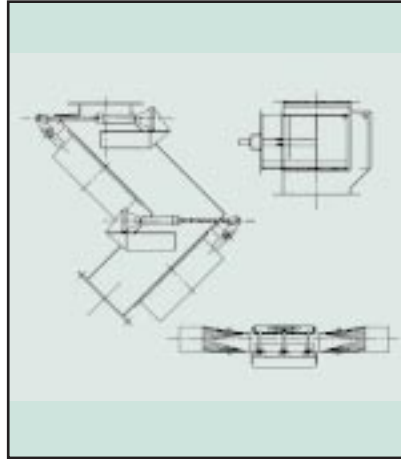

MAGNETS

Magnets are used to remove ferrous tramp metal from dry, bulk materials in both gravity and pneumatic conveying. Drawer-in-housing type magnets are used for gravity flow systems and inline bullet magnets and tube magnets are

used for dilute phase pneumatic convey systems. Magnetic grates can also be incorporated as the grating in **CAMCORP** Bag Dump Stations.

Contact CAMCORP for your Magnet parts & replacements

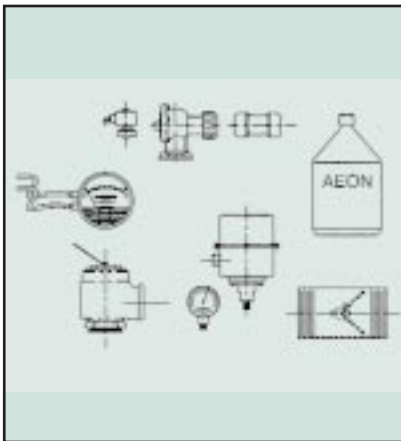

BLOWER ACCESSORIES

A wide variety of accessories are available for blower packages including pressure and vacuum gauges and set point switches, pressure and vacuum relief valves, transducers, temperature gauges

and set point switches, check plate valves, intake & inline filters, and Aeon positive displacement blower lubricant. Vacuum breaker valves and vacuum modulating valves available for vacuum blower packages. Repair kits available for most name brand blowers including Roots, Sutorbilt, MD, Duroflow, Gardner Denver, Kaeser, Rotron and Fuji.

Contact CAMCORP for all your blower package parts & replacements.

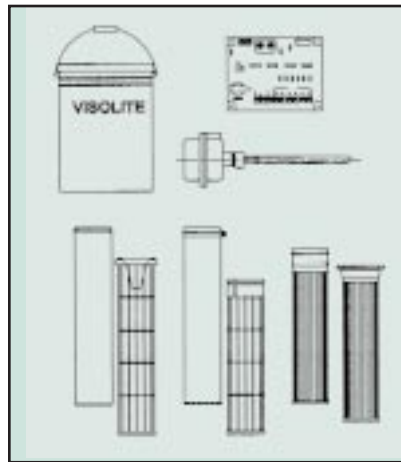

DUST FILTER ACCESSORIES

A broad range of replacement parts and accessories are available for your dust filters. We offer filter bags and cages for top and bottom load, pleated cartridge filters for top and bottom load, cellulose filters, bag

clamps, solenoid & diaphragm valves, timer boards, differential pressure gauges and set point switches, compressed air pressure gauges and regulators. Visolite® leak detection and Broken Bag Detector systems are also available.

Contact CAMCORP for your Dust Filter parts & replacements.