



PRESSURE / VACUUM BLOWER PACKAGE

INSTRUCTION, OPERATIONS & MAINTENANCE MANUAL

CLEAN AIR MANAGEMENT COMPANY, INC.

8224 Nieman Road • Lenexa, Kansas 66214 Phone: 913-831-0740 Fax: 913-831-9271

TABLE OF CONTENTS

General Information -----	2
Principle of Operation -----	3
Installation -----	4
Start-Up-----	5-6
Maintenance -----	7
Troubleshooting -----	8

NOTE:

It is the owner's responsibility to maintain the safety features included with this equipment. The safety features may include, but not necessarily be limited to: guards, access doors and covers, explosion vents, warning decals, caution decals, and advisory decals. Replacement features are available from CAMCORP.

GENERAL COMMENTS:

CAMCORP supplies air pump packages comprised of positive displacement blowers manufactured by various companies. A Service Manual for your specific blower is included as an inset in this manual. For specific maintenance and lubrication information, please refer to this insert.

-READ & UNDERSTAND SAFETY DECALS-

Installation and Operation Cautions:

Be sure that the motor is wired for correct rotation; some models of blower are unidirectional and damage could occur if rotation is reversed. Refer to certified drawing or consult CAMCORP representative for rotation.

Blowers are shipped without lubrication oil, do not operate before lubrication.

All system piping must be clean internally before connecting to blower.

Check lubrication level only when blower is stopped.

Keep inlet and inline filters clean.

Keep belts properly tensioned and aligned.

Use of a check valve on pressure and combination packages will prevent reversing of blower on shutdown.

Keep pressure and/or vacuum relief valves in good condition so that maximum pressure or vacuum is not exceeded.

Never attempt to regulate airflow by restricting intake or exhaust of a positive displacement blower.

PRINCIPLE OF OPERATION

CAMCORP blower packages are set up to provide air to a pressure conveying system or vacuum required for a negative pressure system. Typically the positive displacement blower used on such a package is not capable of supplying air to a pressure higher than 15 psig or vacuum greater than 14" Hg. Depending on the specific blower, it may have a maximum pressure or vacuum capability of somewhat less than that. Because of limitations involved, the blower, motor and line size of the system must be designed specifically to meet the requirements of the system.

Because of the tight clearances used in the design and manufacture of the PD blowers, they require filtered intake air. Proper maintenance of the intake filter will help insure a long service life for your blower.

We recommend you give consideration to building certain precautions into your system. Due to unforeseen circumstances your system may at some point experience an upset condition. By allowing for this when setting up your system, you may minimize the affect of such an occurrence. Three major areas should be considered: the positive displacement blower, the motor and the integrity of the system controls.

Provided, as standard equipment on all of our blower packages is a mechanical relief valve, which is factory set at or below the pressure or vacuum limit of the specific blower. This protects the blower from overheating because flow is decreasing if a line plugs or valve closes at the wrong time. This type of blower is not designed to run at zero airflow.

A properly sized and installed motor starter provides protection for your motor. Hire a qualified electrician to design and install the electrical service to your system.

The integrity of the controls for your system can usually best be maintained during an upset condition by proper use of a pressure or vacuum switch. A pressure/vacuum switch set two to three PSI/Hg. above the expected operating pressure of your system will allow a high pressure or vacuum signal to initiate a preventative action. Check with CAMCORP for expected operating pressure. This may involve stopping the infeed or material to the system to allow it a certain time to clear itself or it may be as simple as triggering an alarm to alert an operation to the condition.

Caution must be taken to be sure that any steps initiated by such an upset condition does not create a problem or even a hazard elsewhere in your process. For example, your upstream equipment may need to be shut down in a very specific sequence. In any case, you need to analyze the affect on your complete process before establishing the actions initiated by an upset condition.

INSTALLATION

CAMCORP's positive displacement blower package consists of a positive displacement blower, a vertical or horizontal frame assembly, a motor, take-up table, or motor slide rails, V-belt drive and belt guard, an air intake or inline filter, intake and discharge silencer, a pressure or vacuum relief valve preset at the maximum pressure or vacuum rating of the blower, flexible connections, a check valve (pressure blower assemblies only), pressure/vacuum gauge and pressure or vacuum switch. (Vacuum blower package does not include an inlet silencer as a standard offering)

Assembly may be accomplished through the following:

1. Locate and anchor the blower base assembly in its permanent location.
2. Check all bolted connections for tightness.
3. Check belts for proper tightness.
4. Zero out pressure or vacuum gauge.
5. Set pressure on pressure/vacuum switch to correct setting.

Lubrication:

CAMCORP uses positive displacement blowers from several manufacturers. General lubrication information is given in the Maintenance Section; for specific information on your positive displacement blower, see the manufacturers manual included with this manual.

CAUTION: All blowers are shipped dry from the factory. Do not attempt to run the blower before following proper lubrication instructions as permanent damage to the gears, bearings and seals will occur.

LOCKOUT / TAGOUT BEFORE PRE – STARTUP CHECK

PRE – START-UP CHECK LIST:

- A. Check alignment of the drive and tension of the belts.
- B. Make sure that the blower and all conveying lines are free of foreign material.
- C. Check pressure relief valve to be sure they are unrestricted.
- D. Check that the blower has been properly lubricated according to the manufacturers insert.
- E. Check the breather-filters on the blower for proper installation.
- F. Turn the blower over by hand to be sure there is no binding.

CAUTION

At this time replace all guards and covers making sure they are securely in place before operating the unit. Never attempt to perform any maintenance on the air pump, drive or conveying system while pump is in operation. System power must be disconnected and locked out prior to servicing.

START-UP

- A. Bump the motor to check for:
 - Freedom of rotation
 - Proper blower rotation
- B. Start unit and operation for fifteen minutes with no load, checking for hot spots, noise and other indications of interference. Allow pump to cool to room temperature and recheck oil level. Add oil if necessary being careful not to overfill.
- C. Start unit and apply load, observe operation for the first hour, monitor pressure/vacuum and air temperature at outlet of the blower.
- D. Check all connections for air leaks.

- E. Check the amp draw of the motor to be sure that the full load amp rating is not exceeded. See motor nameplate.
- Do not operate blower beyond manufacturers recommended limits.
 - Be aware that there are also minimum recommended RPM limitations below which adequate lubrication will not be maintained.
 - Consult the manufacturers insert or factory for the specific limits for this blower.

MAINTENANCE

- A. Check oil level daily
- B. Refer to the general lubrication guidelines in this manual for recommended frequency of oil change and type of oil. For more specific information on blower maintenance and lubrication see the manufacturer's insert (manual) accompanying this manual.
- C. Clean the intake or inline filter every 40 hours or more often if dust conditions are severe. The filter element is washable using luke warm water with mild detergent.
- D. Check the drive belts for tension after the first 24 hours of operations and every 100 hours thereafter. Sheaves and belts should be inspected every 200 hours.
- E. Silencers should be inspected periodically for: 1) being plugged, 2) corrosion, 3) oil coating (discharge silencers) and for any deterioration.

TROUBLESHOOTING POSITIVE DISPLACEMENT ROTARY BLOWERS

<u>Symptom</u>	<u>Possible Causes</u>	<u>Possible Sources</u>
Noisiness	Rotor-to Rotor Contact	Rust Build up or Rotors Rotors Out of Time Excessive Pressure Ratio Failed Bearings (s) Failed Gears
	Failing Bearing (s)	Faulty Installation Non-spec Oil Contaminated Oil Insufficient Oil Improperly Mounted Sheave Over-tightened Belts
	Failing Gears	Insufficient Backlash Non-spec Oil Contaminated Oil Insufficient Oil Sever Torsional Vibration
	Failing Lubricated Coupling or Joint	Non-spec Grease Contaminated Grease Insufficient Grease
	Loose Attached Hardware	Belt Guard Pump Mounting Bracket Frame Members In/Out Piping Supports
	Air Leakage	Improper Relief Valve Setting Blown Gaskets Loose Piping Joints

<u>Symptom</u>	<u>Possible Causes</u>	<u>Possible Sources</u>
	Belt Flutter	Insufficient Static Tension Sheave Misalignment Sever Torsional Vibration
Poor Performance	Restricted Inlet	Clogged Filter Element Collapsed Inlet Hose
	Down Stream Restriction	Clogged Dust Filter Undersized Dust Filter Faulty Check Plate Improperly Installed Check Plate
	Erroneous Pressure or Vacuum Indication	Loose Gauge Connection Gauge Movement Damaged Gauge Inaccurately Calibrated
	Air Leakage	Improper Relief Valve Setting Blown Gaskets Loose Piping Joints
	Insufficient Rotor Speed	Wrong Sheave Set Wrong Motor Speed Slipping Belts
	Excessive Rotor Clearances	Abrasive Wear of Rotor Surfaces Rotor "Lag" Timed
	Change in Conveyed Material	Material More Difficult to Fluidize Material of Higher Density Moisture Content of Material Too High

<u>Symptom</u>	<u>Possible Causes</u>	<u>Possible Sources</u>
Leaking Oil	Failed Oil Seals	Foreign Material in Seal Bores Faulty Installation Non-spec Oil Contaminated Oil Overheated Rotor Shafts
	End Cover Seams Not Tight	Bolts Loose Gaskets Torn
	Oil Foaming	Non-spec Oil Oil Cavities Overfilled
Chronic Fuse Blowing or Circuit Breaking	Excessive Motor Amperage	Excessive Pressure Ratio Excessive Pump Speed Line Voltage Drop Air Density Increase Loose Electrical Connections Foreign Material in Air Box
	Underrated Fuses	
	Premature Heater Strip Actuation	Unusually High Ambient Temperature Underrated Heater Strips
Overheating	Excessive Pressure Ratio	Clogged Filter Element Collapsed Inlet Hose Clogged Dust Vent Filter Undersized Dust Vent Filter Clogged Diffusion Pads Faulty Check Plate Improperly Installed Check Plate
	Insufficient Rotor Speed	Wrong Sheave Set Wrong Motor Speed Slipping Belts

Pressure and vacuum switches contain one or two single pole, double throw switches rated (continuous inductive) for 10 amps at 125 or 250 volts or 3 amps at 480 volts.

The installation and use of this electrical apparatus must be in accordance with the national electrical code and any other applicable local codes and ordinances.

Standard motors supplied by CAMCORP will be 230/460 volt, 3 phase, 60 cycle and control circuits will be 110 volt, single phase, 60 cycle.

Pressure or Vacuum Switch Adjustments: Turn adjustment screw clockwise to lower actuation point.



PARTS LIST OPERATING AND SERVICE MANUAL

LEGEND “P” SERIES BLOWERS

2” – 5” GEAR
DIAMETER

Models

GAA__ P__
GAB__ P__
GAC__ P__
GAE__ P__



SB-7-621
Version 06
April 2, 2007

**MAINTAIN BLOWER RELIABILITY AND PERFORMANCE
WITH GENUINE GARDNER DENVER
PARTS AND SUPPORT SERVICES**

Factory genuine parts, manufactured to design tolerances, are developed for optimum dependability - - - specifically for your blower. Design and material innovations are born from years of experience with hundreds of different blower applications. When you specify factory genuine parts you are assured of receiving parts that incorporate the most current design advancements manufactured in our state-of-the-art blower factory under exacting quality standards.

Your AUTHORIZED DISTRIBUTOR offers all the backup you require. A worldwide network of authorized distributors provides the finest product support in the blower industry.

1. Trained parts technical representatives to assist you in selecting the correct replacement parts.
2. Complete inventory of new machines and new, genuine factory parts.
3. A full line of factory tested AEON™ PD blower lubricants specifically formulated for optimum performance in all blowers.
4. Authorized distributor service technicians are factory-trained and skilled in blower maintenance and repair. They are ready to respond and assist you by providing fast, expert maintenance and repair service.

INSTRUCTIONS FOR DETERMINING BLOWER CONFIGURATION

1. Face the blower drive shaft.
2. In a **VERTICAL** configuration, air flow is horizontal.
3. In a **HORIZONTAL** configuration, air flow is vertical.
4. In a vertical configuration, a **BOTTOM HAND** exists when the drive shaft is below the horizontal center line of the blower. A **TOP HAND** exists when the drive shaft is above the horizontal center line of the blower.
5. In a horizontal configuration, a **RIGHT HAND** exists when the drive shaft is to the right of the vertical center line of the blower. A **LEFT HAND** exists when the drive shaft is to the left of the vertical center line of the blower.

INSTRUCTIONS FOR ORDERING REPAIR PARTS

For pricing, and ordering information contact your nearest AUTHORIZED FACTORY DISTRIBUTOR. When ordering parts, specify Blower **MODEL** and **SERIAL NUMBER** (see nameplate on unit).

Rely upon the knowledge and experience of your AUTHORIZED DISTRIBUTOR and let them assist you in making the proper parts selection for your blower.

For the location of your local authorized Gardner Denver blower distributor refer to the yellow pages of your phone directory, check the Web site at www.gardnerdenver.com or contact:

Gardner Denver Compressor Division
1800 Gardner Expressway
Quincy, IL 62305
Phone: (217) 222-5400
Fax: (217) 221-8780

GARDNER DENVER LUBRICANT ORDER INFORMATION

Re--order Part Numbers for Factory--Recommended Lubricants.

Gear End

AEON PD Synthetic Lubricant or AEON PD--Food Grade Synthetic Lubricant

AEON PD Synthetic Lubricant

<u>Description</u>	<u>Part Number</u>
1 Quart	28G23
Case/12Quarts	28G24
1 Gallon Container	28G40
5 Gallon Pail	28G25
55 Gallon Drum	28G28

AEON PD--Food Grade Synthetic Lubricant

<u>Description</u>	<u>Part Number</u>
1 Quart	28H97
Case/12Quarts	28H98
1 Gallon Container	28H333
5 Gallon Pail	28H99
55 Gallon Drum	28H100

Drive End

AEON PD Grease

<u>Description</u>	<u>Part Number</u>
Case/10 Tubes	28H283

Call your local Sutorbilt Distributor to place your order for Gardner Denver lubricants. Your Authorized Gardner Denver Distributor is:

FOREWORD

Sutorbilt® blowers are the result of advanced engineering and skilled manufacturing. To be assured of receiving maximum service from this machine, the owner must exercise care in its operation and maintenance. This book is written to give the operator and maintenance department essential information for day-to-day operation, maintenance and adjustment. Careful adherence to these instructions will result in economical operation and minimum downtime.



Danger is used to indicate the presence of a hazard which will cause severe personal injury, death, or substantial property damage if the warning is ignored.



Warning is used to indicate the presence of a hazard which can cause severe personal injury, death, or substantial property damage if the warning is ignored.



Caution is used to indicate the presence of a hazard which will or can cause minor personal injury or property damage if the warning is ignored.

NOTICE

Notice is used to notify people of installation, operation or maintenance information which is important but not hazard-related.

SAFETY PRECAUTIONS

Safety is everybody's business and is based on your use of good common sense. All situations or circumstances cannot always be predicted and covered by established rules. Therefore, use your past experience, watch out for safety hazards and be cautious. Some general safety precautions are given below:



Failure to observe these notices could result in injury to or death of personnel.

- **Keep fingers and clothing away** from revolving fan, drive coupling, etc.
- **Do not use the air discharge** from this unit for breathing – not suitable for human consumption.
- **Do not loosen or remove the oil filler plug, drain plugs, covers or break any connections, etc., in the blower air or oil system until the unit is shut down and the air pressure has been relieved.**
- **Electrical shock** can and may be fatal.
- **Blower unit must be grounded** in accordance with the National Electrical Code. A ground jumper equal to the size of the equipment ground conductor must be used to connect the blower motor base to the unit base.
- **Open main disconnect switch, tag and lockout** before working on the control.
- **Disconnect the blower** from its power source, tag and lockout before working on the unit – this machine may be automatically controlled and may start at any time.



Failure to observe these notices could result in damage to equipment.

- **Stop the unit** if any repairs or adjustments on or around the blower are required.
- **Disconnect the blower** from its power source, tag and lockout before working on the unit – this machine maybe automatically controlled and may start at any time.
- **Do not exceed** the rated maximum speed shown on the nameplate.
- **Do not operate unit** if safety devices are not operating properly. Check periodically. **Never bypass safety devices.**

I

TABLE OF CONTENTS

Maintain Blower Reliability And Performance.....	2
Foreword.....	4
Safety Precautions.....	5
Sutorbilt Legend Series Blowers Matrix/Menu.....	8
Introduction.....	9
Section 1, Equipment Check.....	10
Section 2, Installation.....	12
Section 3, Lubrication.....	17
Section 4, Operation.....	20
Section 5, Special Tools Required.....	23
Section 6, Disassembly Instructions.....	25
Section 7, Assembly Instructions.....	28
Section 8, Parts List.....	35

INDEX

Aeon PD Food Grade Lubricant	18	Mechanical Seals Only	28, 29
Aeon PD Synthetic Lubricant	18	Mounting Configurations.....	12
Air Filters And Filter Silencers	16		
Assembly Instructions, Section 7	28	Operation, Section 4.....	20
		Parts List, Section 8.....	35
Blower Startup Checklist.....	21	Piping	14
		Recommended Lubricant	18
Disassembly Instructions, Section 6	25	Removing Protective Materials.....	10
Drive End Lubrication	17	Repositioning The Mounting Feet.....	12
Drive Installation	13		
		Safety Precautions	5
Equipment Check, Section 1		Safety Precautions	22
Equipment Check	10		
		Section 7	
Foundations.....	12	Assembly Instructions.....	28
		Setting Impeller End Clearance With Mechanical Seals.....	33
Gear End Lubrication.....	17	Setting Impeller End Clearances	32
Installation, Section 2.....	12	Special Tools Required Section 5.....	23
Installing The Timing Gears.....	31	Storage	10
Introduction.....	9		
		Trouble Shooting	22
Limitations	20		
Location	12	Warranty.....	44
Lubrication, Section 3.....	17		

LIST OF ILLUSTRATIONS

FIGURE 2-1 – BLOWER MOUNTING CONFIGURATION	13
FIGURE 2-2 – BELT DRIVE OVERHUNG LOAD CALCULATIONS	15
FIGURE 3-1 - LUBRICATION.....	17
FIGURE 3-2 – APPROXIMATE OIL CAPACITIES	18
FIGURE 3-3 – AEON PD SYNTHETIC LUBRICANT	18
FIGURE 3-4 – LUBRICATION RECOMMENDATION	19
FIGURE 4-1 – MAXIMUM OPERATING LIMITATIONS	20
FIGURE 5-1 – PULLER PLATE.....	23
FIGURE 5-2 – GEAR DRIVER – 208GAA074	23
FIGURE 5-3 – MECHANICAL SEAL INSTALLATION TOOL	24
FIGURE 5-4 – BEARING PRESS TOOL – MECHANICAL SEAL UNITS.....	24
FIGURE 6-1 – DISASSEMBLY ILLUSTRATIONS.....	25
FIGURE 6-2 – DISASSEMBLY ILLUSTRATIONS.....	25
FIGURE 6-3 – DISASSEMBLY ILLUSTRATIONS.....	26
FIGURE 6-4 – DISASSEMBLY ILLUSTRATIONS.....	26
FIGURE 6-5 – DISASSEMBLY ILLUSTRATIONS.....	26
FIGURE 6-6 – DISASSEMBLY ILLUSTRATIONS.....	27
FIGURE 7-1 – ASSEMBLY ILLUSTRATIONS.....	28
FIGURE 7-2 – ASSEMBLY ILLUSTRATIONS.....	29
FIGURE 7-3 – ASSEMBLY ILLUSTRATIONS.....	29
FIGURE 7-4 – ASSEMBLY ILLUSTRATIONS.....	30
FIGURE 7-5 – ASSEMBLY ILLUSTRATIONS.....	31
FIGURE 7-6 – ASSEMBLY ILLUSTRATIONS.....	33
FIGURE 7-7 – ASSEMBLY ILLUSTRATIONS.....	33
FIGURE 7-8 – TORQUE (FT-LBS).....	34

SUTORBILT LEGEND SERIES BLOWERS MATRIX/MENU

NOTICE TO CUSTOMER – To find the construction options for Your blower unit, FILL IN THE BALANCE OF LETTERS OR NUMBERS FROM YOUR UNIT NAMEPLATE

	G	A			P																												
COLUMN NUMBER:	1	2	3	4	5	6	7																										
<p>FOLLOW THE LINE DOWN AND OVER FROM EACH SPACE THUS FILLED IN TO FIND THE APPROPRIATE CONSTRUCTION OPTION WITH WHICH YOUR MACHINE IS EQUIPPED.</p> <p>COLUMN 1 – BASIC DESIGNATOR _____</p> <p>COLUMN 2 – PRODUCT FAMILY _____</p> <p>COLUMN 3 – GEAR DIAMETER _____</p> <table style="margin-left: 20px; border-collapse: collapse;"> <tr> <td style="padding-right: 5px;">A</td><td style="border-left: 1px solid black; padding: 0 5px;">2"</td><td style="border-right: 1px solid black; padding: 0 5px;">E</td><td style="border-left: 1px solid black; padding: 0 5px;">5"</td><td style="border-right: 1px solid black; padding: 0 5px;">H</td><td style="padding: 0 5px;">8"</td></tr> <tr> <td>B</td><td style="border-left: 1px solid black; padding: 0 5px;">3"</td><td style="border-right: 1px solid black; padding: 0 5px;">F</td><td style="border-left: 1px solid black; padding: 0 5px;">6"</td><td style="border-right: 1px solid black; padding: 0 5px;"></td><td></td></tr> <tr> <td>C</td><td style="border-left: 1px solid black; padding: 0 5px;">4"</td><td style="border-right: 1px solid black; padding: 0 5px;">G</td><td style="border-left: 1px solid black; padding: 0 5px;">7"</td><td style="border-right: 1px solid black; padding: 0 5px;"></td><td></td></tr> </table> <p>COLUMN 4 – CASE LENGTH _____</p> <table style="margin-left: 20px;"> <tr><td>L</td><td>-</td><td>Low Pressure</td></tr> <tr><td>M</td><td>-</td><td>Medium Pressure</td></tr> <tr><td>H</td><td>-</td><td>High Pressure</td></tr> </table> <p>COLUMN 5 – CONFIGURATION _____</p> <ul style="list-style-type: none"> A Vertical-Top Hand -Central Timed B Vertical-Bottom Hand – Central Timed C Horizontal – Left Hand – Central Timed D Horizontal – Right Hand – Central Timed <p>COLUMN 6 – DESIGN VERSION _____</p> <p>COLUMN 7 – ADDITIONAL DESCRIPTION _____</p> <ul style="list-style-type: none"> A. Lip Seal B. Mechanical Seal 	A	2"	E	5"	H	8"	B	3"	F	6"			C	4"	G	7"			L	-	Low Pressure	M	-	Medium Pressure	H	-	High Pressure						
A	2"	E	5"	H	8"																												
B	3"	F	6"																														
C	4"	G	7"																														
L	-	Low Pressure																															
M	-	Medium Pressure																															
H	-	High Pressure																															

INTRODUCTION

YOUR KEY TO TROUBLE FREE SERVICE

Thank you for investing in Sutorbilt quality. The Sutorbuilt reputation for rugged dependability has been earned by over 50 years of service in demanding, industrial operations where downtime cannot be tolerated and efficient blower performance is expected.

Your Sutorbilt blower is a precision engineered blower that has been carefully manufactured and thoroughly tested at the state-of the art Gardner Denver Blower Factory in Sedalia, Missouri.

As with other precision machinery, there are several relatively simple installation, operation and maintenance procedures that you must observe to assure optimum blower performance. There is no guesswork in the manufacture of your highly advanced Sutorbilt blower and there must be none in preparing the blower to get the job done in the field.

The purpose of this manual is to help you properly install, operate and maintain your Sutorbilt blower. It is essential that you review all sections of this manual in preparation for installing your blower. Follow the instructions for installing your blower. Follow the instructions carefully and you will be rewarded with trouble-free Sutorbilt service year in and year out.

SECTION 1 EQUIPMENT CHECK

Before uncrating, check the packing slip carefully to be sure all the parts have been received. All accessories are listed as separate items on the packing slip, and small important accessories such as relief valves can be overlooked or lost. After every item on the packing slip has been checked off, uncrate carefully.

NOTICE

Register a claim with the carrier for lost or damaged equipment.

WARNING

Customers are cautioned to provide adequate protection, warning and safety equipment necessary to protect personnel against hazards involved in installation and operation of this equipment in the system or facility.

STORAGE

Your Gardner Denver Blower was packaged at the factory with adequate protection to permit normal storage for up to six (6) months.

If the unit is to be stored under adverse conditions or for extended periods of time, the following additional measures should be taken to prevent damage.

1. Store the blower in a clean, dry, heated (if possible) area.
2. Make certain inlet and discharge air ports are tightly covered to prevent foreign material from entering the air box.
3. All exposed, non-painted surfaces should be protected against rust and corrosion.
4. Provide adequate protection to avoid accidental mechanical damage.
5. In high humidity or corrosive environments, additional measures may be required to prevent rusting of the blower internal surfaces.
6. To prevent rusting of gears, bearings, etc., the oil reservoirs may be filled with normal operating oil.

CAUTION

Before running the blower, drain the oil and replace to the proper operating level with clean, fresh lubricant.

7. Rotate the blower shaft (10 to 25 turns) weekly during storage. Inspect the blower shaft (near the shaft seal area) monthly and spray with rust inhibitor if needed.
8. For long term storage (over six (6) months), contact Gardner Denver Compressor Division Customer Service for recommendations.

REMOVING PROTECTIVE MATERIALS

The shaft extension is protected with rust inhibitor which can be removed with any standard solvent.

CAUTION

Follow the safety directions of the solvent manufacturer.

Blower inlet and outlet are temporarily capped to keep out dirt and other contaminants during shipment. These covers must be removed before start-up.

The internal surfaces of all Sutorbilt units are mist sprayed with a rust preventative to protect the machine during shipment. Remove this film upon initial startup, using any commercial safety solvent. Position the blower so that the inlet and discharge connections are in the vertical position (vertical airflow). On vertically mounted units, it will be necessary to lay the unit on its side supporting the ends of the unit so as not to restrict the port on the bottom side. Place a shallow pan on the under side of the unit. With the blower disconnected from power, spray the solvent in the top port, rotating the impellers by spinning the shaft manually. Continue this procedure until the unit is visibly clean.



Rotating components will cause severe injury in case of personal contact. Keep hands and loose clothing away from blower inlet and discharge ports.

SECTION 2 INSTALLATION

LOCATION

Install the blower in a well lit, clean dry place with plenty of room for inspection and maintenance.

FOUNDATIONS

For permanent installation we recommend concrete foundations be provided, and the equipment should be grouted to the concrete. It is necessary that a suitable base be used, such as a steel combination base under blower and motor, or a separate sole plate under each. Before grouting, equipment must be leveled, free of all stains, and anchored so no movement will occur during setting of grout. After grout has completely hardened, a recheck is necessary to compensate for shrinkage, etc. If required, add shims under blower feet after final tightening of foundation anchor bolts to remove strain from the blower housing.

Where jack screws or wedges are used during grouting, they must be backed off and wedges removed before final tightening of anchor bolts. Refer to grouting instructions.

Where a concrete foundation is not feasible, care must be taken to insure that equipment is firmly anchored to adequate structural members, restricting movement and vibration.

MOUNTING CONFIGURATIONS

The blower flex-mount design enables horizontal and vertical mounting configurations with top or bottom hand, right or left hand shaft positioning. The units are center timed allowing rotation in either direction (refer to Figure 2-1). If converting a blower from vertical to horizontal, or horizontal to vertical mounting configuration, additional mounting feet will be required.

REPOSITIONING THE MOUNTING FEET.

1. Position the mounting feet to the desired location and snug the capscrew.
2. Place the blower on its feet on a flat surface.
3. Loosen mounting feet capscrews and level unit up. The bench or blower base flatness should be within .002 of an inch.

NOTICE
If the unit is not flat within .002 of an inch, it will be necessary to shim the blower feet at installation.

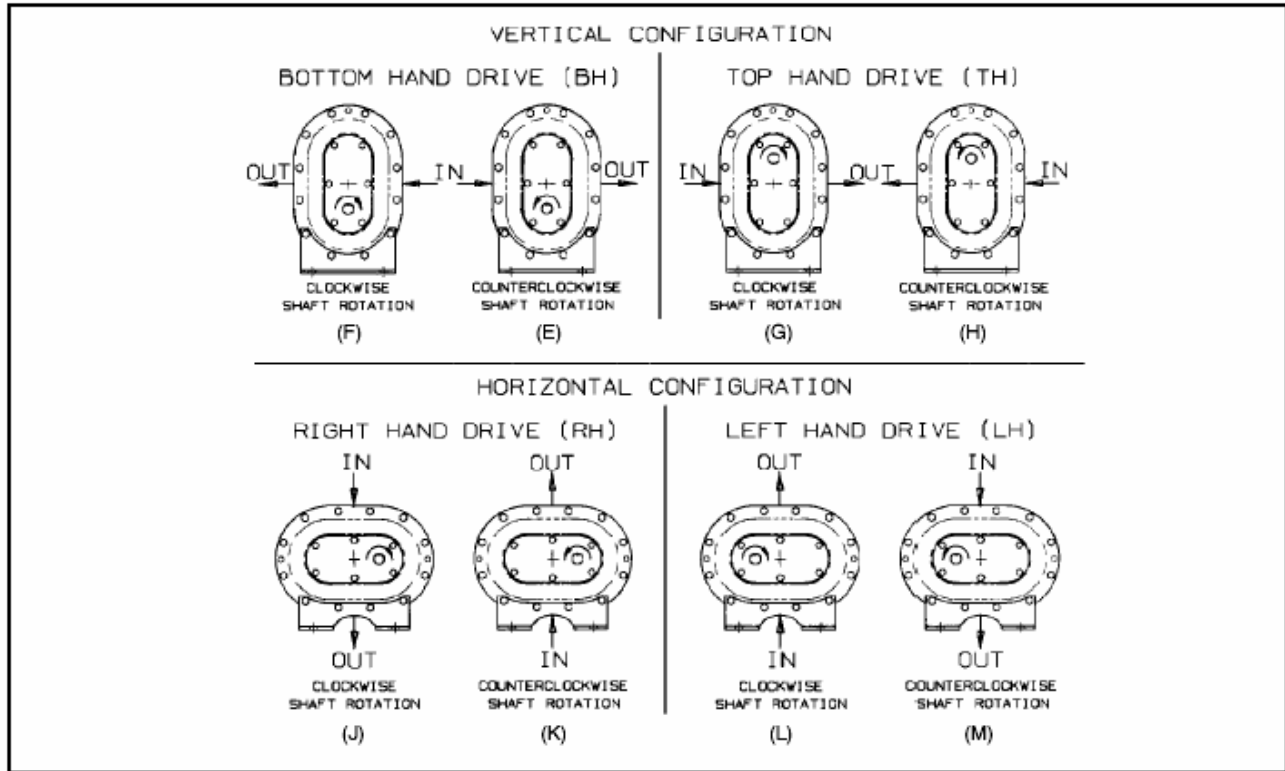

FIGURE 2-1 – BLOWER MOUNTING CONFIGURATIONS

4. Secure the mounting feet capscrews to the torque value in Figure 7-8, page 34.

NOTICE

When changing mounting configuration, it may be necessary to reposition vent plug (B), and drain plug (A). Refer to Figure 3-1, page 17, for correct location.

DRIVE INSTALLATION

When selecting a V-belt drive, check to be sure the shaft overhung load limitation is not exceeded. Refer to FIGURE 2-2, page 15, for overhung load calculations and limitations.

Belt drives must be carefully aligned. Motor and blower pulleys must be parallel to each other and in the same plane within 1/32 inch. Belt tension should be carefully adjusted to the belt manufacturer's recommendation using a belt tension gauge. Check tension frequently during the first day of operation.

⚠ WARNING

Over tightening belts leads to heavy bearing loads and premature failure.

On the direct connected units, alignment and lubrication of couplings to specifications of the coupling manufacturer is very important. When mounted drives are supplied from the factory proper alignment has been established before shipment. However, during shipping, handling and installation, it is likely that the alignment has been disturbed and final adjustment must be made before startup.

 **WARNING**

Exceeding overhung load limitations leads to unwarrantable premature bearing failure and shaft breakage.

The location of the sheave on the blower shaft greatly affects the stress in the shaft. The optimum blower sheave positioning is as close as possible to the blower drive cover, not to exceed dimension “C” in Drive Shaft Illustration, FIGURE 2-2, page 15

The calculated shaft moment must not exceed the maximum allowable moment listed in Maximum Allowable Moment Chart, FIGURE 2-2 page 15. If the calculated shaft moment exceed the maximum allowable moment:

- Increase Sheave Diameters to Reduce Belt Pull
- Use Jackshaft Drive
- Use Direct Coupled or Gearbox Drive

To calculate shaft moment for a given V-Belt Drive Arrangement:

1. Use the formula for Calculation of Belt Pull, FIGURE 2-2, page 15, to calculate belt pull. Refer to Arc of Contact Factor Chart, Figure 2-2, page 15.
2. Insert the calculated belt pull into the formula for Calculation of Shaft Moment, FIGURE 2-2, page 15 to arrive at the calculated shaft moment.

PIPING

Inlet and discharge connections on all blowers are large enough to handle maximum volume with minimum friction loss. Reducing the pipe diameter on either inlet or discharge will only create additional line loss and increase the overall pressure differential. Excessive weight of piping and fittings will cause internal misalignment and premature wear. Never allow the blower to carry the weight of the pipe. If possible, a spool or sleeve-type expansion joint should be installed between the unit and the piping. Where a flexible connection is not practical, the weight of the rigid connection must be separately supported.

All system piping must be cleaned internally before connecting to the blower.

 **WARNING**

Sutorbilt blowers are shipped dry from the factory. Do not attempt to operate the blower before following proper lubrication instructions. Permanent damage to the gears, bearings and seals will occur.

Gear Diameter (Inches)	Dimensions (Inches)			Maximum Allowable Moment (LB-IN)
	A	B	C (Max)	
2	2.76	.80	.38	146
3	2.88	.85	.38	385
4	3.49	1.10	.38	490
5	3.90	1.40	.38	1245

MAXIMUM ALLOWABLE MOMENT

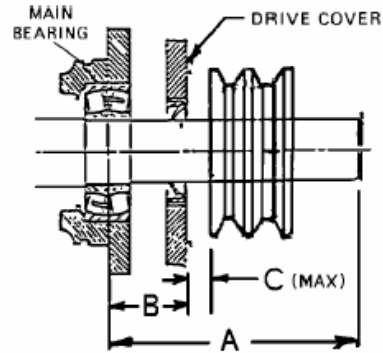

DRIVE SHAFT ILLUSTRATION

Z	Ac	Z	Ac	Z	Ac	Z	Ac	Z	Ac	Z	Ac
0.000	1.000	0.250	0.966	0.500	0.926	0.750	0.879	1.000	0.823	1.250	0.751
0.025	0.997	0.275	0.962	0.525	0.922	0.775	0.874	1.025	0.816	1.275	0.742
0.050	0.994	0.300	0.958	0.550	0.917	0.800	0.869	1.050	0.810	1.300	0.734
0.075	0.990	0.325	0.954	0.575	0.913	0.825	0.864	1.075	0.803	1.325	0.725
0.100	0.987	0.350	0.951	0.600	0.908	0.850	0.858	1.100	0.796	1.350	0.716
0.125	0.983	0.375	0.947	0.625	0.904	0.875	0.852	1.125	0.789	1.375	0.706
0.150	0.980	0.400	0.943	0.650	0.899	0.900	0.847	1.150	0.782	1.400	0.697
0.175	0.977	0.425	0.939	0.675	0.894	0.925	0.841	1.175	0.774	1.425	0.687
0.200	0.973	0.450	0.935	0.700	0.889	0.950	0.835	1.200	0.767		
0.225	0.969	0.475	0.930	0.725	0.884	0.975	0.829	1.225	0.759		

ARC OF CONTACT FACTORS

Belt Pull = $\left[\frac{2.5 - A_c}{A_c} \right] \times \left[\frac{125954 \times H_p \times S.F.}{D \times RPM} \right]$

Key:

- A_c = Arc of Contact Factor (Refer to Arc of Contact Factor Chart above)
- H_p = Blower Horsepower for Operating Conditions
- S.F. = Actual Drive Service Factor
- D = Blower Sheave Pitch Diameter in Inches
- RPM = Blower Sheave Speed
- Z = $\left[\frac{\text{Large Sheave Pitch Diameter (in)} - \text{Small Sheave Pitch Diameter (in)}}{\text{Sheave Center Distance (in)}} \right]$

CALCULATION OF BELT PULL

$$\text{Shaft Moment (LB-IN)} = \text{Belt Pull} \times \left[B + C + \left(\frac{\text{Sheave Width}}{2} \right) \right]$$

CALCULATION OF SHAFT MOMENT

FIGURE 2-2 – BELT DRIVE OVERHUNG LOAD CALCULATIONS

AIR FILTERS AND FILTER SILENCERS



Servicing the air filters is one of the most important maintenance operations to be performed to insure long blower life.

Servicing frequency of filter elements is not time predictable. A differential pressure indicator, with a continuous gauge reading, should be installed across the inlet filter. It will tell how much of the service life of the filter element has been used. It will also eliminate both premature filter servicing and premature blower failure due to a plugged filter when the filter pressure drop is used to establish maintenance points. In all cases refer to the filter manufacturer's service instructions. Due to the many types of filters, it is not practical to give specific instructions covering all models.

NOTICE

No matter what type of filter is used, always make sure all seats, gaskets, clamps and hose connections on the filter and inlet line are absolutely air tight. Each time the filter is serviced, inspect interior of the blower for dirt.

SECTION 3 LUBRICATION

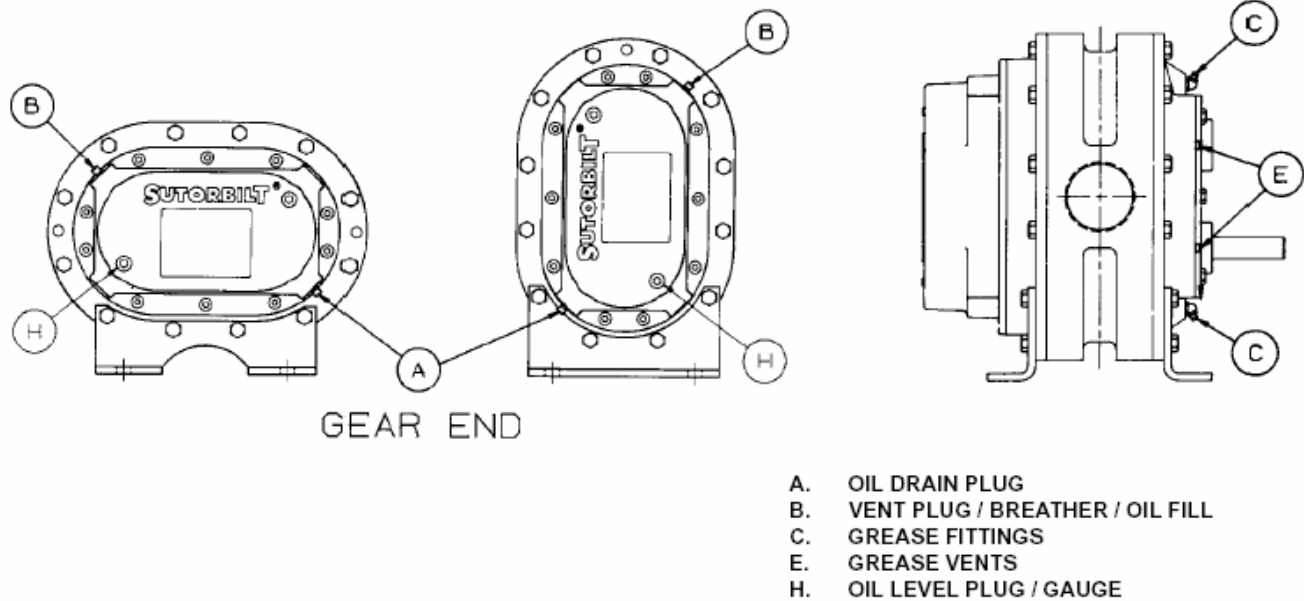

GEAR END

- A. OIL DRAIN PLUG
- B. VENT PLUG / BREATHER / OIL FILL
- C. GREASE FITTINGS
- E. GREASE VENTS
- H. OIL LEVEL PLUG / GAUGE

FIGURE 3-1 - LUBRICATION

DRIVE END LUBRICATION

Drive end bearings are grease lubricated at the factory with Lithium Complex based grease. **For relubrication, use Gardner Denver AEON PD Grease, Part Number 28H283.** AEON PD Grease is a high temperature, high performance grease that is formulated with antiwear additives to provide superior service under the severe operating conditions of positive displacement blowers. It contains rust inhibitors which provide excellent protection against rust and corrosion.

If you choose not to use AEON PD Grease, select compatible base grease. The grease should be NLGI Grade 2 EP, contain rust inhibitors, and be suitable for blower discharge temperatures up to 350° F (177° C). Completely clean or purge the factory--filled grease from the blower. **Do not mix different types of grease as they may not be compatible. Substitutions may cause early bearing failure.**

Re-grease bearings every 500 hours of operation. Lubricate each bearing through the grease fittings located at C in FIGURE 3-1 (2 places). When re-greasing, the old grease will be forced out of the vents (E in FIGURE 3-1). To prevent damage to seals, these vents must be open at all times.



WARNING

Do not over--grease bearings as this could cause premature bearing failure.

GEAR END LUBRICATION

At the gear end, the timing gear teeth are lubricated by being partially submerged in oil. The gear teeth serve as oil slingers for gear end bearings.

Approximate oil sump capacities are listed in FIGURE 3-2, page 18.

RECOMMENDED LUBRICANT

Gear Diameter	Vertical	Horizontal
2"	1/4 PT.	1/2 PT.
3"	1/3 PT.	2/3 PT.
4"	3/4 PT.	1 PT.
5"	1 PT.	2-1/4 PT.

FIGURE 3-2 – APPROXIMATE OIL CAPACITIES

The factory recommended lubricant is **AEON PD Synthetic Lubricant**. AEON PD is formulated especially for positive displacement blowers to provide maximum protection at any temperature. One filling of AEON PD will last a minimum of 4 times longer than a premium mineral oil, depending on actual operating conditions. AEON PD contains a special additive package designed for greater rust and corrosion protection.

AEON PD Lubricant	
Description	Part Number
1 Quart	28G23
Case/12 Quarts	28G24
1 Gallon Container	28G40
5 Gallon Pail	28G25
55 Gallon Drum	28G28
AEON PD Food Grade Lubricant	
Description	Part Number
1 Quart	28H97
Case/12 Quarts	28H98
1 Gallon Container	28H333
5 Gallon Pail	28H99
55 Gallon Drum	28H100

FIGURE 3-3 – AEON PD SYNTHETIC LUBRICANT

NOTICE

Machines are shipped without oil in the sump. Do not operate before adding lubricant.

LUBRICATION INSTRUCTIONS

Filling Procedure (For 2" and 3" sizes)

Refer to FIGURE 3-1, page 17. Remove the oil level plug (H) and the square head vented oil fill plug (B) from the gear cover. Add oil to the gear case until oil drips out of the oil level hole (H). Secure plugs in their correct location.

Filling procedure (For 4" and 5" sizes)

Refer to FIGURE 3-1, page 17. Remove the breather (B) from the gear cover. Add oil to the gear case until oil reaches the center of the oil level gauge (H). Secure breather (B) in the gear cover.

Add fresh oil as required to maintain proper level. The oil level should be at the middle of the sight glass when the machine is not operating.

⚠ WARNING

Do not overfill as this will tend to cause excessive heating of the gears and may damage the unit.

AEON PD Synthetic Lubricant should be drained after 6000 hours of operation. Re-fill with fresh AEON PD oil. If mineral oil is used, perform the above oil—change maintenance every 1500 hours. Recommended service intervals are for normal blower operating conditions. Severe operating conditions may warrant more frequent oil changes. Laboratory analysis of lubricant should be used to help determine the optimum oil change interval.

For best performance and equipment protection, use AEON PD Synthetic Lubricant, which has been specifically formulated for positive displacement blowers. If you choose not to use AEON PD Synthetic Blower Lubricant, select an oil with rust and oxidation inhibitors, anti-foam additives, and the viscosities listed in FIGURE 3-4, page 19. Do not use an oil that contains EP additives.

NOTICE

Flush the oil whenever a change is made from one type of oil to another.

Drain the current lubricant as thoroughly as possible. Refill with the new lubricant. Fill to normal level of the blower, which is at the middle of the sight glass when the machine is not operating. Run the blower for one hour. Shut off the blower and drain the lubricant completely. Refill the blower again with the new lubricant.

Blower Discharge Temperature	Ambient Temperature			
	Less than 10° F*	10° F to 32° F**	32° F to 90° F	Greater than 90° F
Less than 32° F (0° C)	ISO 100 ‡	ISO 100 ‡		
32° F to 100° F (0° C to 38° C)	ISO 100 ‡	ISO 100 ‡	ISO 150 ‡	
100° F to 225° F (38° C to 105° C)	ISO 100 ‡	ISO 100 ‡	ISO 150 ‡	ISO 220 ‡
225° F to 300° F (105° C to 149° C)	ISO 150 ‡	ISO 150 ‡	ISO 220 ‡	ISO 220 ‡
Greater than 300° F (149° C)			*** ‡	*** ‡

* For ambient temperatures less than 10° F, but not less than -20° F, the use of oil sump heaters, heated enclosures or synthetic lubricant is required.

** For ambient temperatures 10° F to 32° F, the use of oil sump heaters, heated enclosures or synthetic lubricant is recommended.

*** The lubricant viscosity must be 70 SUS minimum at the lubricant operating temperature.

The pour point of the lubricant should be at least 5° to 10° F below the minimum expected ambient temperature.

For continuous operation, where the lubricant temperature exceeds 200° F, synthetic lubricant is recommended.

‡ The recommended operating range for AEON PD Synthetic Lubricant.

FIGURE 3-4 – LUBRICATION RECOMMENDATION

**SECTION 4
OPERATION**

Future operating problems can be avoided if proper precautions are observed when the equipment is first put into service.

Before starting under power, the blower should be turned over by hand to make certain there is not binding or internal contact.

Each size blower has limits on pressure differential, running speed and discharge temperature which must not be exceeded. These limits are shown in "Maximum Operating Limitations", FIGURE 4-1, below.

⚠ WARNING
Operating beyond the specified operating limitations will result in damage to the unit.

It is important that the pressures and temperatures are measured directly at the ports of the blower to avoid error that may be caused by intervening pipe runs, fittings, etc.

Relief valves must be used to protect against excessive pressure or vacuum conditions. These valves should be tested at initial startup to be sure they are adjusted to relieve at or below the maximum pressure differential rating of the blower.

NOTICE
Relief valves should be placed as close as possible to the blower inlet or discharge.

In some instances, pressure may be relieved at a lower point than the blower maximum in order to protect the motor or the equipment served by the blower.

Discharge temperature switches are recommended to protect against excessive inlet restriction or inlet temperatures. Check valves in the discharge line on pressure blowers and in the inlet line on vacuum blowers are recommended to protect the blower from motoring backwards when shut down under load.

LIMITATIONS

For information regarding limitations, refer to FIGURE 4-1, below.

MAXIMUM OPERATING LIMITATIONS				
SIZE	RPM	PRESSURE PSI	VAC IN HG	DISCHARGE TEMPERATURE ° F
2LP	5275	7	14	285
2MP	5275	12	15	315
3LP	3600	7	14	260
3MP	3600	12	15	280
3HP	3600	15	16	320
4LP	3600	7	14	260
4MP	3600	10	16	285
4HP	3600	15	16	310
5LP	2850	7	14	260
5MP	2850	13	16	280
5HP	2850	15	16	300

DO NOT EXCEED THESE LIMITS

NOTICE
Blower speed, line losses, elevation, and increased inlet temperatures will affect the maximum operating limitations.

FIGURE 4-1 – MAXIMUM OPERATING LIMITATIONS

BLOWER STARTUP CHECKLIST

This startup procedure should be followed during the initial installation and after any shutdown periods or after the blower has been worked on or moved to new location. It is suggested that the steps be followed in sequence and checked off (v) in the boxes provided.

1. Check the unit and all piping for foreign material and clean if required.
2. Check the flatness of the feet and the alignment of the drive. Feet that are bolted down in a bind can cause housing distortion and internal rubbing. Misaligned V-drives can cause the rotors to rub against the headplates and cause a reduction in the volumetric efficiency of the unit. Misaligned couplings can ruin bearings.
3. If the blower is V-belt driven, check the belt tension and alignment. Over-tensioned belts create heavy bearing/shaft loads which lead to premature failure.
4. Be sure adequate drive guards are in place to protect the operator from severe personal injury and incidental contact.
5. Check the unit for proper lubrication. Proper oil level cannot be over-emphasized. Too little oil will ruin bearings and gears. Too much oil will cause overheating and can ruin gears and cause other damage. Insure that grease lubricated bearings are properly lubricated.
6. With motor electrical power locked out and disconnected, turn the drive shaft by hand to be certain the impellers do not bind.
7. "Jog" the unit with the motor a few times to check that rotation is in the proper direction, and to be certain it turns freely and smoothly.
8. The internal surfaces of all Sutorbilt units are mist sprayed with a rust preventive to protect the machine during the shipping and installation period. This film should be removed upon initial startup.
9. Start the unit and operate 15 minutes at no load. During this time, check for hot spots and other indications of interference.
10. Apply the load and observe the operation of the unit for one hour. Check frequently during the first day of operation.
11. If malfunctions occur, do not continue to operate. Problems such as knocking rotors can cause serious damage if the unit is operated without correction.

SAFETY PRECAUTIONS

1. Do not operate blower with open inlet or outlet port.
2. Do not exceed specified vacuum or pressure limitations.
3. Do not operate above or below recommended blower speed range.
4. Blower is not to be used where non-sparking equipment is specified.
5. Do not operate without belt guard or coupling shield.



Do not exceed sheave or coupling manufacturer's rim speed limit.

6. The blower and blower discharge piping may be extremely hot and cause skin burns on contact.

TROUBLE SHOOTING

No matter how well the equipment is designed and manufactured, there may be times when servicing will be required due to normal wear, the need for adjustment, or various external causes. Whenever equipment needs attention, the operator or repairman should be able to locate the cause and correct the trouble quickly. The Trouble Shooting Chart below is provided to assist the mechanic in those respects.

PROBLEM	POSSIBLE CAUSES	SOLUTION
Knocking	<ol style="list-style-type: none"> 1. Unit out of time. 2. Distortion due to improper mounting or pipe strains. 3. Excessive pressure differential. 4. Worn gears. 5. Worn bearings. 	<ol style="list-style-type: none"> 1. Re-time impellers 2. Check mounting alignment and relieve pipe strains. 3. Reduce to manufacturer's recommended pressure. Examine relief valve, re-set if necessary. 4. Replace timing gears. 5. Replace bearings..
Excessive blower temperature.	<ol style="list-style-type: none"> 1. Too much oil in gear case. 2. Too low operating speed. 3. Dirty air Filter. 4. Clogged filter or muffler. 5. Excessive pressure differential. 6. Worn impeller clearances. 7. Internal contact. 	<ol style="list-style-type: none"> 1. Reduce oil level. 2. Increase blower speed. 3. Clean or replace air filter 4. Remove cause of obstruction. 5. Reduce pressure differential across the blower. 6. Replace impeller. 7. Correct clearances.
Impeller end or tip drag.	<ol style="list-style-type: none"> 1. Insufficient assembled clearances. 2. Case or frame distortion. 3. Excessive operating pressure. 4. Excessive operating temperature. 	<ol style="list-style-type: none"> 1. Correct clearances. 2. Check mounting and pipe strain. 3. Remove cause. 4. Remove cause
Lack of volume.	<ol style="list-style-type: none"> 1. Slipping belts. 2. Worn clearances. 3. Dirty air filter 	<ol style="list-style-type: none"> 1. Tighten belts. 2. Re-establish proper clearances. 3. Clean or replace air filter.
Excessive bearing or gear wear.	<ol style="list-style-type: none"> 1. Improper lubrication. 	<ol style="list-style-type: none"> 1. Correct lubrication level. Replace dirty oil.
Loss of oil.	<ol style="list-style-type: none"> 1. Headplate, gear case or drive cover vents plugged. 2. Worn Seal. 	<ol style="list-style-type: none"> 1. Clean vents. 2. Replace seals.

**SECTION 5
MAINTENANCE**

ORDER SPECIAL TOOLS BY PART NUMBER. SEE PAGE 1 FOR ORDERING INSTRUCTIONS.

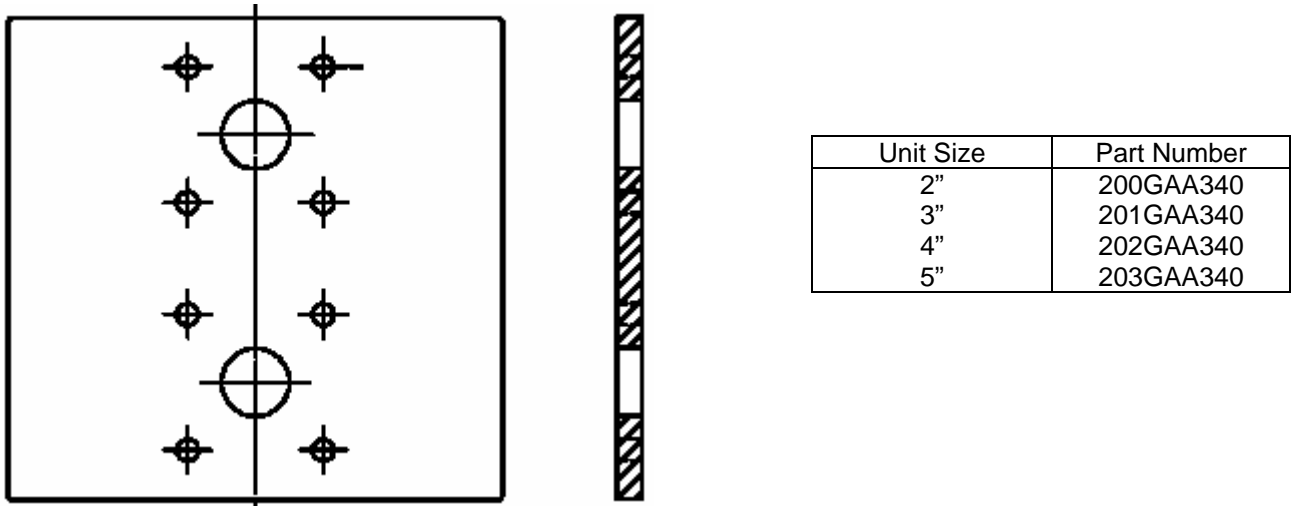

FIGURE 5-1 – PULLER PLATE

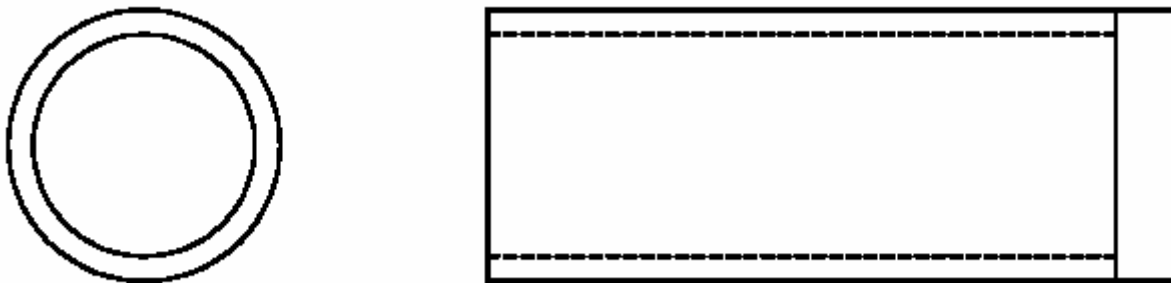
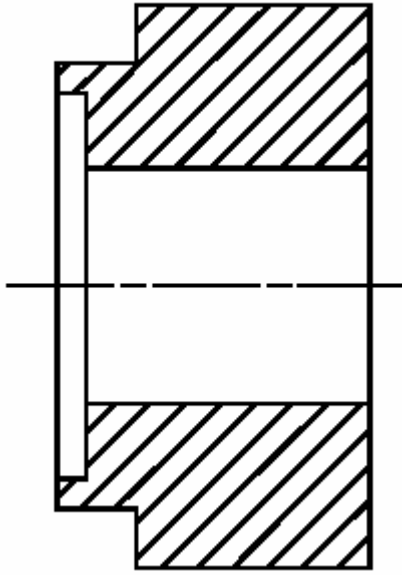
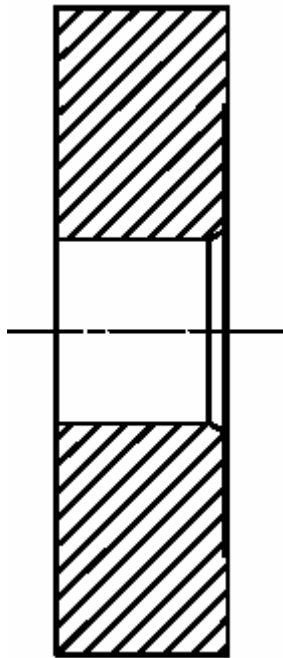

FIGURE 5-2 – GEAR DRIVER – 208GAA074



Unit Size	Part Number
2"	204GAA074
3"	205GAA074
4"	206GAA074
5"	207GAA074

FIGURE 5-3 – MECHANICAL SEAL INSTALLATION TOOL



Unit Size	Part Number
2"	200GAA074
3"	201GAA074
4"	202GAA074
5"	203GAA074

FIGURE 5-4 – BEARING PRESS TOOL – MECHANICAL SEAL UNITS

SECTION 6 DISASSEMBLY INSTRUCTIONS

NOTICE

Numbers in parentheses () refer to key numbers in assembly drawings on pages 35, 37, 39 and 41.

1. Drain oil from gear case by removing drain plug (4).
2. Remove the socket head bolts (5) from the gear cover (3).
3. Remove the gear cover from the gear headplate.

NOTICE

The cover and gear headplate gasket tends to bond tightly to both surfaces. After socket head bolt removal, it is sometimes necessary to take a ball peen hammer and a blunt chisel and drive off the cover.

IMPORTANT:

MARK ALL PARTS WITH A CENTER PUNCH SO THEY CAN BE REASSEMBLED IN THE SAME POSITION (IMPELLERS, HEADPLATES, AND GEARS).

4. If the timing gears appear undamaged, the gear backlash must be checked to see if the gears can be salvaged.
 - A. Mount a magnetic base dial indicator on the gear headplate (see FIGURE 6-1).
 - B. Lock one impeller stationary by wedging a feeler gauge between the impeller and the headplate.
 - C. The tip of the indicator should be placed at the center of the contact surface on a tooth of the gear on the free shaft.
 - D. Rock the impeller back and forth by hand and read the total rotational movement to the nearest .0005 inches. Do this at four gear mesh positions 90 degrees apart.
 - E. Permissible gear backlash is shown below.

GEAR DIA.	GEAR BACKLASH
2"	.0015 - .0025
3"	.0015 - .0025
4"	.0015 - .0025
5"	.002 - .003

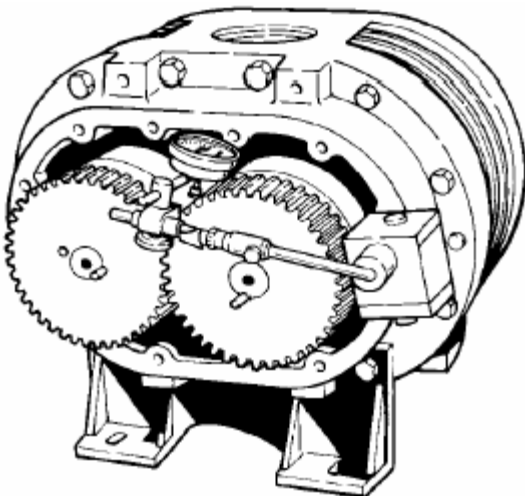

FIGURE 6-1

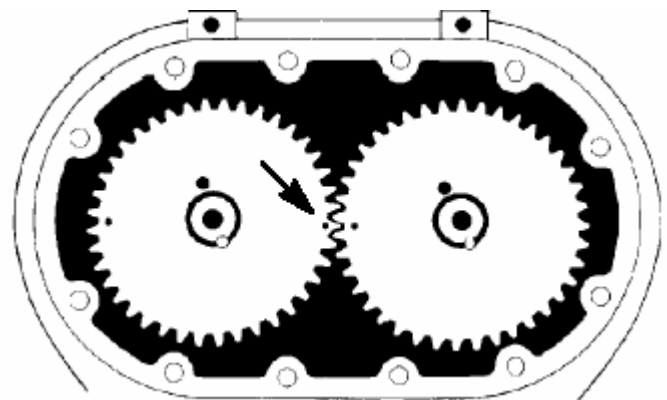

FIGURE 6-2

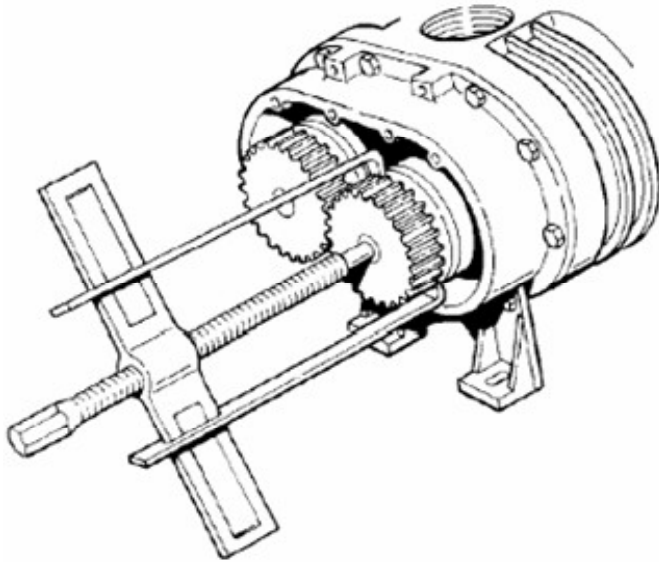

FIGURE 6-3

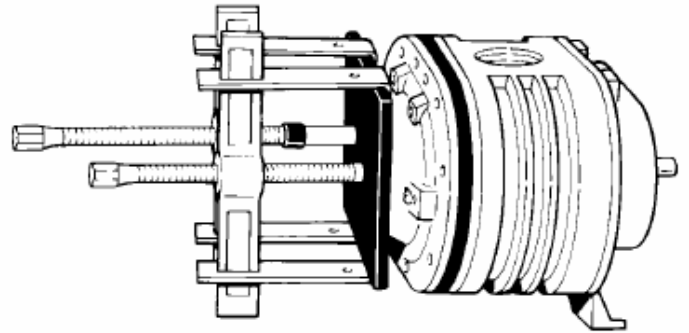

FIGURE 6-4

NOTICE

If backlash is above the specified limit, the gears are not necessarily unusable. Excessive play could be caused by worn bearings.

5. If timing gears appear to be reusable, match mark timing gear toothmesh by making small punch marks on the ends of meshing gear teeth with a pin punch and hammer (see FIGURE 6-2, page 25). The impeller tip to valley (throat) and the case to headplates should also be matchmarked to facilitate blower reassembly.
6. Using a gear puller, remove timing gears. The taper pin should back out with the gear as the gear is being removed (see FIGURE 6-3). Use caution not to damage gear teeth with puller if gears are to be used again.

NOTICE

Blowers with mechanical seals have two wavy washers (28) located between the bearings and the cover on the drive end.

7. Remove the socket head cap screws (30) from the drive end bearing cover (29) and remove the cover. Drive shaft oil seal (31) should come free when cover is removed.

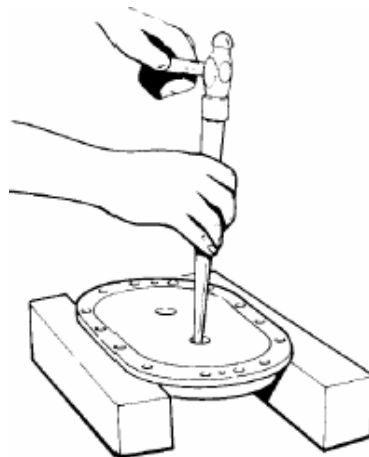

FIGURE 6-5

8. Remove mounting foot (17) from the drive headplate (24) by removing the capscrews (16).
9. Remove the capscrews (21) which secure the drive headplate (24) to the impeller case (22).
10. Using the puller plate shown on page 23, bolt to the drive headplate using the tapped holes used to secure the drive cover.
11. Install a gear puller to each shaft and attach puller arms to the plate. Turn each puller only half a revolution at a time keeping the advance of the shafts as uniform as possible (see Figure 6-4). After the headplate has been removed, detach the puller plate.
12. Remove the two drive end bearings (15) from the drive headplate (24) using a ball peen hammer and punch (see Figure 6-5, page 26).

⚠ CAUTION

Exercise care not to damage the headplate bearing bores when removing bearings.

13. The grease seals can now be driven out of the drive headplate with hammer and punch (see Figure 6-5, page 26). Discard the seals as they will not be reused. Replace grease seals each time the headplate is removed.

NOTICE

Seals and bearings should be replaced during overhaul as a matter of service policy.

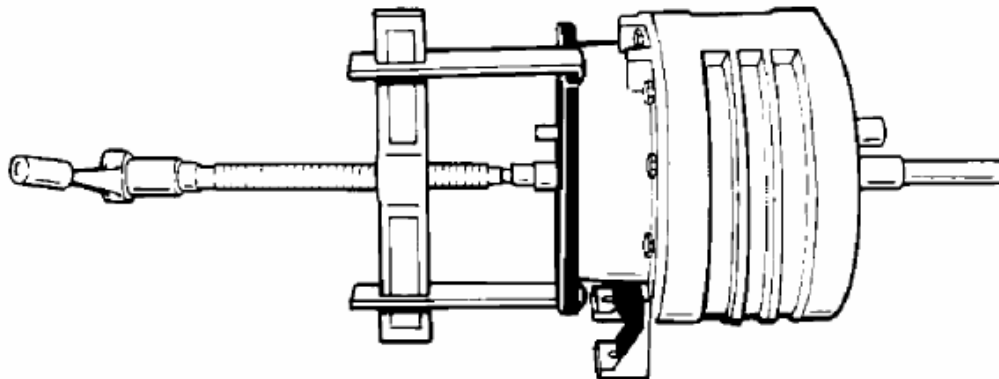

FIGURE 6-6

14. Remove the four cap screws (10), which fasten the bearing retainers (12) to the gear headplate.
15. Attach puller plate to the gear headplate using the tapped holes used to secure the bearing retainers.
16. Install a gear puller to one of the shafts and attach puller arms to the plate (see Figure 6-6).
17. Remove mounting foot (17) from the gear headplate by removing 4 capscrews (16).
18. Push the impeller shaft through the gear headplate and remove the impeller assembly(23) (see Figure 6-6). Remove the other impeller assembly following the same procedure.
19. Remove the cap screws (21) securing the gear headplate to the impeller case. Located near each dowel pin on the headplate is a threaded hole. Insert a 5/16-18 UNC capscrew into each of the threaded holes. Tighten the screws evenly until the headplate separates from the impeller case.
20. Remove the two gear and bearings (14) from the gear headplate (18) as done in step 12.
21. Remove the oil seals (15) from gear headplate (19) as done in step 13.

SECTION 7 ASSEMBLY INSTRUCTIONS

NOTICE

Numbers in parentheses () refer to key numbers in assembly drawings on pages 35, 37, 39 and 41.

1. Make sure all metallic parts are clean and free of any nicks or burrs.
2. Lubricate the outside diameter of the lip seal (15) with a light oil or grease. Install seals in both the drive headplate (24) and gear headplate (18). The seal lip should always face towards the bearing or lubricant. New seals should be installed each time the headplate is removed.

NOTICE

Make sure seals are fully seated. Use extreme care when installing.

MECHANICAL SEALS ONLY

- A. Lightly coat the headplate bores with assembly lubricant.
- B. Refer to Figure 7-1. Install mechanical seal (A) into the headplate bore (C) using a press and the correct driver shown on page 24. Drive the seal securely on to its seat.

CAUTION

Use extreme care when installing seals in the headplate bores. Do not attempt to install the mechanical seals without the use of a press. Blows from a hammer or mallet can damage the fragile seal surface. Too much force can crush the seal casing. Make certain the seal is properly seated and undamaged before proceeding.

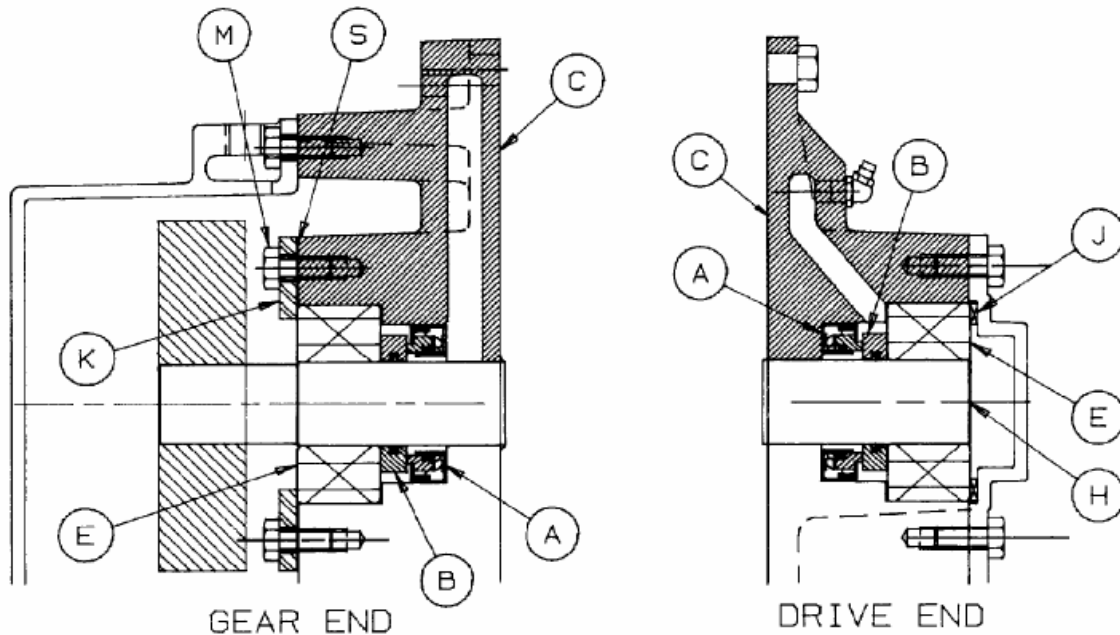

FIGURE 7-1

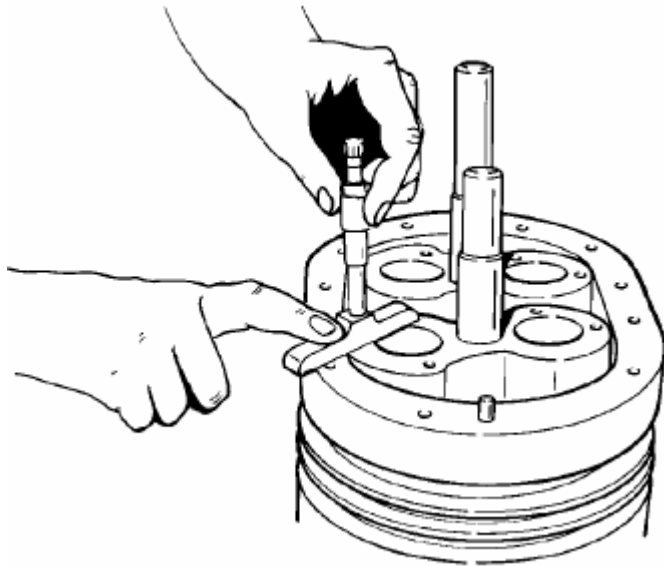

FIGURE 7-2

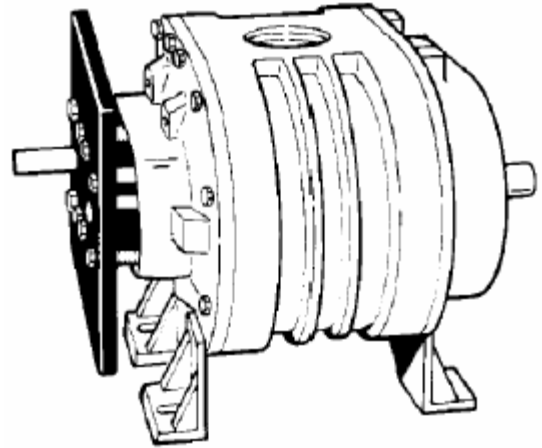

FIGURE 7-3

3. Assemble gear headplate (18) and mounting foot (17) to the impeller case with cap screws (21) and where the mounting foot is secured to the headplate use capscrews (16). The two positioning dowel pins (19) will ensure proper alignment of the headplate and impeller case. Also secure lifting lugs using cap screws (21) (see exploded assembly drawing on page 35. Refer to Figure 7-8, page 34, for torque specifications.

⚠ CAUTION

Seals are delicate; use extreme care when installing impeller shafts in the headplate bores. A piece of light shim stock wrapped around the shaft keyway will prevent cutting the seal lip.

4. Apply a light oil or grease on the shaft seal areas and the bearing areas. Insert impellers into the gear headplate using the same headplate bores as used in the original assembly.
5. Position blower so that impellers are vertical, with the drive end on top. It will be necessary to use blocks in order for the unit to set level. Measure the total end clearance using a depth micrometer (see Figure 7-2).

NOTICE

If more than .007" shim is required, put .007" on the drive end and the remaining on the gear end.

If total clearance is not within the limits specified in Figure 7-4, page 30, it may be necessary to shim the case to obtain the proper total end clearance. The shim should be placed between the drive headplate and impeller case.

6. Assemble drive headplate (24) to impeller case as in step 3 with the gear headplate. If shims were required, place shims between drive headplate and impeller case.

MECHANICAL SEALS ONLY

- A. Refer to Figure 7-1, page 28. Lightly coat the impeller shaft (H) and the inside diameter of the mating ring (B) with assembly lubricant.
- B. Install the mating ring (B) on the shaft only far enough to get the bearing (E) started on the shaft.

⚠ CAUTION

Do not drive the mating ring down to the mechanical seal, as this can damage the seal.

- C. Lightly lubricate the bearing inner race (E) with a light oil or grease.
- D. Using a press, install the bearing on the shaft with the bearing driver shown on page 24.

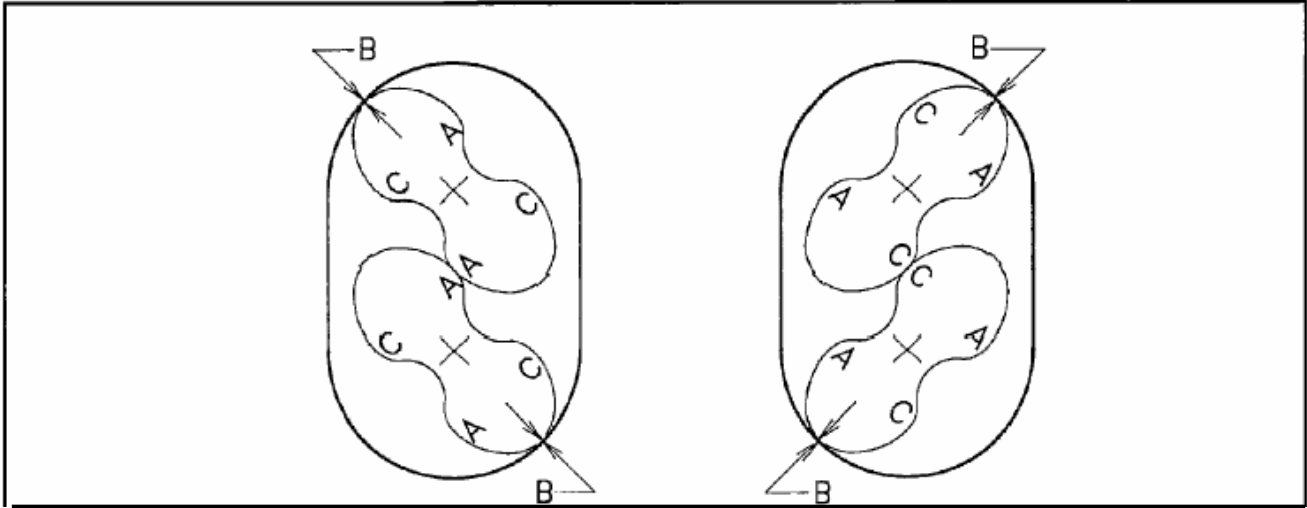

CLEARANCES FOR STANDARD UNITS ONLY

	2M	2L	3H	3M	3L	4H	4M	4L	5H	5M	5L
TOTAL END CLEARANCE	.006-.009		0.007-0.011			0.007-0.011			0.007-0.011		
IMPELLER TO GEAR HEADPLATE	.003-.004		0.003-0.005			0.003-0.005			0.003-0.005		
IMPELLER TIMING (A-A) (C-C)	.005-.008		0.005-0.007	.006-.008		0.006-0.008	.007-.010		.007-.010	.008-.010	
TIP TO CASE CLEARANCE (B-B)	0.002 min.		0.002 min.			0.002 min.			0.002 min.		

FIGURE 7-4

The bearing driver will position the mating ring (B) to the correct depth with respect to the mechanical seal (A).

7. Apply a light oil to the drive headplate bearing bore, bearing inside diameter, and shaft seat. Install the drive end bearings (14) as far as possible without force.
8. Attach the puller plate shown on page 23 to the drive headplate using the tapped holes used to secure the drive cover (see FIGURE 7-3, page 29). Tighten the bolts so that the advance of the bearings stay as uniform as possible. Bearings should be pressed until flush with the drive headplate.
9. Lubricate the gear end bearing fits with a light oil as described previously. Install gear end bearings (14) as far as possible without force. Use the plate, used to install the drive end bearings, to press the bearings on the shafts as described in Step 8. Press bearings into the gear headplate until completely seated in the bearing bore.

NOTICE

Bearings will not be flush with gear headplate bores when completely seated.

10. Impellers should now be checked for free axial movement by hitting the ends of the impeller shafts with the palm of your hand.
11. Push the impellers against the gear headplate and recheck the total end clearance between the drive headplate and the impellers (see FIGURE 7-4).
 - A. If total end clearance is insufficient, loosen impeller case to headplate bolts on either headplate, and move the headplate away from the case far enough to insert a paper shim in the amount equal to the insufficient clearance. Retighten case bolts and again check the total end clearance. Refer to FIGURE 7-4 for correct clearance.
 - B. Excessive end clearances normally will require new impeller assemblies, but in some circumstances the impeller case can be removed and reduced in width by machining off the amount of excess clearance.

CAUTION

These impeller-to-impeller and impeller-to-case clearances are extremely critical. Even though the blower may turn freely by hand when cold, under operating conditions, the parts expand, and the rotors are subject to slight deflection.

If the clearances are not sufficient, the impellers may contact each other or the housing with destructive results. If the clearances are too great, the blower may not develop the pressure or airflow that is required to perform its function.

12. Impeller tip to case clearance should be checked at this time by inserting the correct thickness feeler gauge between the tip and the case and rotating the impeller (see FIGURE 7-4, page 30). Repeat the procedure on both impellers.

NOTICE

When checking the tip to case clearance, move the feeler gauge over the entire length of the impeller to ensure that the tips do not bind along their length.

13. INSTALLING THE TIMING GEARS

- A. Apply a light grease, or oil, on the shaft area where the timing gear will be positioned.
- B. Place feeler stock in the amount of 1/3 of the total end clearance between drive headplate and both impellers. This will stop the impellers from contacting the headplate while the gears are being driven on.

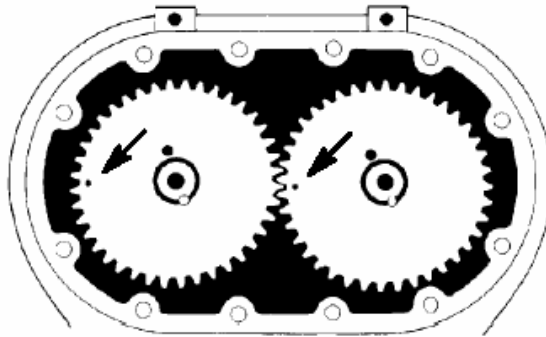

FIGURE 7-5

CAUTION

If installing gears on a blower containing mechanical seals, a press must be used to drive the gears on the shafts. Blows from a hammer or mallet will damage the seal.

- C. Secure the bearing retainer plate (12) to the gear headplate using capscrews (10). Refer to FIGURE 7-8, page 34, for torque specifications.
- D. If reusing the timing gears, the gears should be returned to their original positions. Use taper pin holes and matchmarks for correct positioning.

NOTICE

Replacement gears have minimum backlash marks on the outside diameter of the gear face. These marks should be located 180 degrees from each other (see FIGURE 7-5).

E. Using the driving tool shown on page 23, drive one gear flush with the end of the shaft and re-ream the original hole between the shaft and the gear if movement between the shaft and gear was negligible. If re-reaming fails to eliminate edges set up by re-timing, drill a new hole approximately 90 degrees from the original hole. Apply a thin coat of Loctite 620 to the taper pin and install the taper pin in the reamed hole between the shaft and the gear. Control the depth of the taper pin leaving approximately 1/8 in, taper pin protruding beyond the end of the shaft..

NOTICE

If gears are being replaced, taper pin holes must be drilled after the gears are correctly positioned. Be careful not to let cuttings drop behind the gears and contaminate the bearings.



Be careful not to let cuttings drop behind the gears and contaminate the bearings.

- F. Place impellers in the position shown in FIGURE 7-4, page 30. Check to be sure impellers are in correct position as previously match marked.
- G. Drive the mating gear on the other shaft within 1/2" of being flush with the end of the shaft.
- H. Refer to diagram in FIGURE 7-4, page 30. Use feeler gauges to check clearances between impeller lobes at positions A--A and C--C. Add the clearances, and divide the total clearance evenly between A--A and C--C.
- I. If the lobe clearance is not equal between A--A and C--C, the impellers require shifting relative to the gears. Insert a feeler gauge .010 inch larger than required clearance between the impellers at the tight spot and rotate the impellers wedging the feeler gauge between the lobes. Place the driving tool against the gear that is not flush with the end of the shaft, and strike the driver with a quick blow. This will drive the gear further onto the shaft, causing it to turn relative to the shaft due to the torque value set--up by the oversized feeler gauge wedged between the impeller lobes. Adjust so that the clearance at A--A is equal to C--C within .001 inch. Clearances must be checked on both sides of each impeller lobe over the entire length. This procedure may require repeating several times until the impeller lobe clearance is equal on both sides.

NOTICE

The gear used for adjustment should be flush with its mate on completion of the timing.

- J. Check gear backlash four places at 90 degree intervals as described in the disassembly procedure (Item 4).

NOTICE

If any of the four gear backlash readings are not within the specified limits, the gears must be replaced.

- 14. After timing adjustments are completed, re-ream the original hole between shaft and adjustment gear if movement between the shaft and gear are negligible. If reaming fails a new hole approximately 90 degrees from the original hole. Apply a thin coat of Loctite 620 to the taper pin and install the taper pin in the reamed hole between the shaft and gear.

NOTICE

Replacement gears are not drilled. These holes must be drilled after the gears are in the proper position and the unit retimed.

15. SETTING IMPELLER END CLEARANCES

Refer to FIGURE 7-6, page 33. The outer races of the gear end bearings are clamped against the headplate (F) by the bearing retainer (B).

This is referred to as the "fixed end". The interference fit between the shaft and the bearing inner race (H) keeps the shaft from moving axially. Adjustment is by movement of the shaft through the gear end bearing inner race (H).

- A. Check the total end clearance by adding the clearance between the impellers and the drive headplate to the clearance between the impellers and the gear headplate.

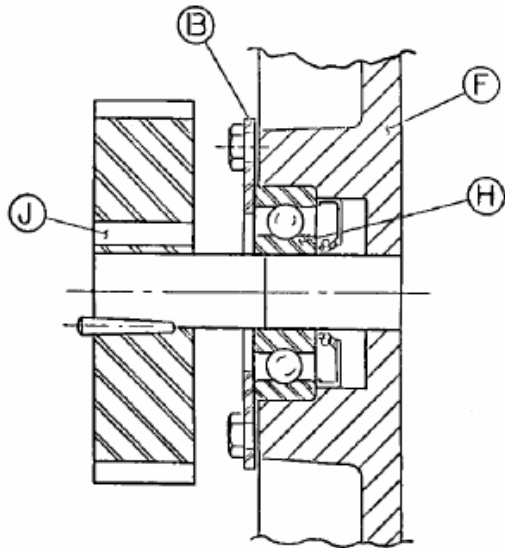

FIGURE 7-6

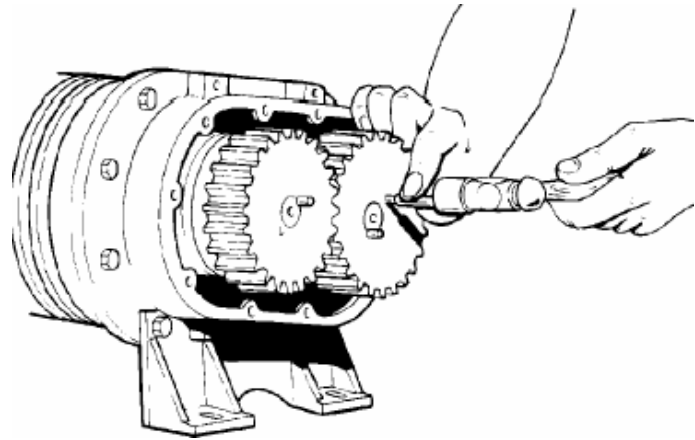

FIGURE 7-7

NOTICE

Check the clearance over the entire width of the impeller and consider the tightest spot.

- B. Divide the total end clearance by 3 and distribute approximately 1/3 on the gear end and the remaining 2/3 on the drive end.
- C. To move the impeller assembly toward the drive end, lightly tap the shaft at the gear end with a soft face mallet.
- D. To set the fixed end, insert the feeler gauge in the amount specified in FIGURE 7-4, page 30, between the headplate and the impeller at the gear end.
- E. Insert a mild steel or soft metal rod thru the small hole in the gear (9). Tap lightly until the feeler gauge is snug. Adjust both impellers using the same procedure. Rotate the impellers checking for clearance through a complete revolution (see FIGURE 7-7).

SETTING IMPELLER END CLEARANCE WITH MECHANICAL SEALS

Refer to FIGURE 7-1, page 28. The gear end bearings are held in position by the force created by the wavy spring (J) on the drive end and the bearing retainer (K) on the gear end. This is referred to as the fixed end. The interference fit between the shaft (H) and the bearing inner race (E) keeps the shaft from moving axially.

End clearance adjustment is by movement of the bearing retainer (K). Tightening the bearing retainer screws (M) moves the bearing to load the wavy spring (J), and the impeller is forced toward the drive end. Relaxing the screws allows the wavy spring to return the impeller toward the gear end.

- A. Assemble drive cover to drive headplate. Refer to Step 16 with the exception of the use of wavy springs (J) installed between the drive end bearings and the drive cover.
- B. Back out retainer screws (M) until both impellers are tight against the gear headplate.
- C. With feeler gauge, measure the clearance between each impeller and the drive headplate. This value is the total end clearance.
- D. Measure the clearance between the gear headplate and bearing retainer (K) at point (S).
- E. Subtract 1/3 of the total end clearance from the clearance measured at point (S). This value is the amount of shim (13) that should be placed between the retainer and the headplate at point (S).
- F. Tighten the bearing retainer screws (M) to the torque value given in FIGURE 7-8, page 34. With the retainer screws secure, approximately 1/3 of the total end clearance should be on the gear end and the remaining 2/3 on the drive end.

16. Replace drive shaft grease seal (31) in the drive end cover (29). The seal lip should always face towards the bearing or lubricant. Pack bearing cavities with recommended grease and secure drive cover with capscrews (30) to drive headplate. Refer to FIGURE 7-8 for torque specifications.

⚠ CAUTION
Exercise care not to damage the seal lip as it passes over the shaft keyway.

17. Assemble the gear cover (3) and gasket (7) to the gear headplate (18) using capscrews (5). Tighten the capscrews alternately and evenly. Refer to FIGURE 7-8 for torque specifications.

18. Place the blower on its feet on a flat surface. Loosen cap screws (16) and level the unit up. The bench or blower base flatness should be within .002 of an inch. Re-tighten cap screws (16) to the specification in FIGURE 7-8.

NOTICE
If the unit is not flat within .002 of an inch, it will be necessary to shim the blower feet at installation.

FASTENERS	GEAR DIAMETER			
	2	3	4	5
CAPSCREW (21)	13 – 17	23 – 30	23 – 30	23 -- 30
CAPSCREW (16)	13 – 17	23 – 30	23 – 30	23 -- 30
SOCKET HD CAPSCREW (5)	6 – 8	6 – 8	13 – 17	13 -- 17
SOCKET HD CAPSCREW (30)	6 – 8	6 – 8	13 – 17	6 -- 8
CAPSCREW (10)	6 – 8	6 – 8	13 – 17	13 -- 17

NOTE: () DENOTES ITEMS IN EXPLODED VIEW DRAWINGS ON PAGES 35, 37, 39 AND 41.

FIGURE 7-8 – TORQUE (FT-LBS)

**SECTION 8
PARTS LIST**

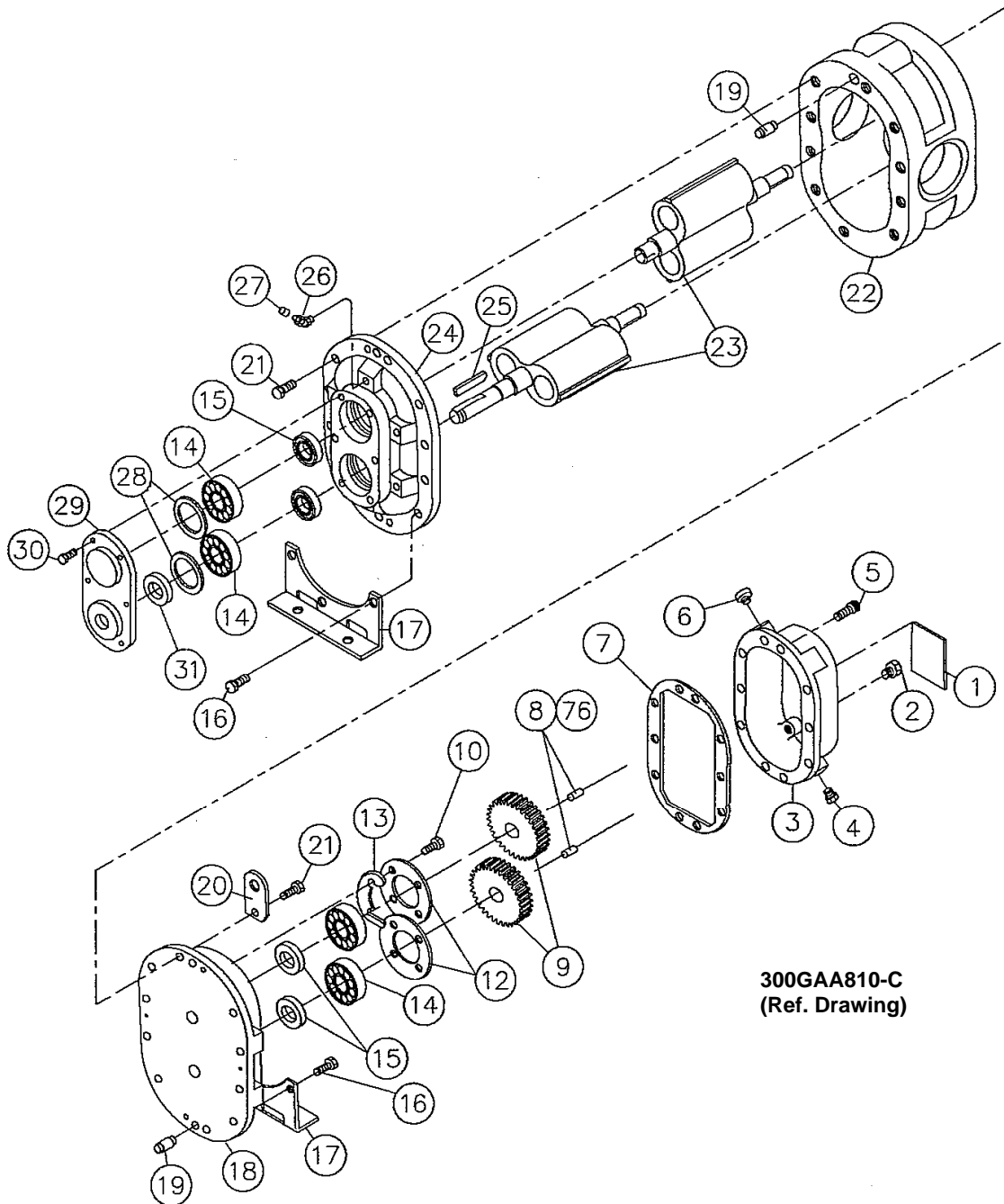

**300GAA810-C
(Ref. Drawing)**

Order by Part Number and Description. Reference Numbers are for your convenience only.

Ref. No.	Description	No. Req'd	MODEL GAA	
			Size -- 2M GAAM_P	Size -- 2L GAAL_P
1	NAMEPLATE.....	1	302GAA496	302GAA496
2	OIL LEVEL PLUG.....	2	64AC1	64AC1
3	GEAR CASE.....	1	900893022801	900893022801
4	DRAIN PLUG.....	1	64AC1	64AC1
5	SCREW--GEAR CASE TO BEARING HOUSING	6	75LM224	75LM224
6	VENT PLUG	1	900639650102	900639650102
O 7	GASKET GEAR CASE	1	200GAA715	200GAA715
O 8	TAPER PIN.....	2	62V73	62V73
9	TIMING GEAR GROUP.....	1	200GAA6008	200GAA6008
O 10	SCREW--BEARING RETAINER TO BEARING	8	75A185N	75A185N
12	BEARING RETAINER	2	900892021801	900892021801
+ 13	SHIM SET.....	1	900891022900	900891022900
O 14	BEARING	4	12BA142	12BA142
O 15	MAIN SEAL--PER APPLICATION BELOW			
	LIP SEAL VERSION.....	4	60DD713	60DD713
	MECHANICAL SEAL VERSION.....	4	900871020002	900871020002
16	SCREW--FOOT TO BEARING HOUSING	6	75A34	75A34
17	FOOT GROUP			
	VERTICAL FOOT GROUP	1	GAA81896	GAA81896
	HORIZONTAL FOOT GROUP	1	GAA81897	GAA81897
18	HOUSING--BEARING (GEAR END)			
	LIP SEAL.....	1	900894021001	900894021001
	MECHANICAL SEAL.....	1	204GAA006	204GAA006
19	DOWEL PIN	4	62M48	62M48
20	LIFTING LUG	2	200GAA451	200GAA451
21	SCREW--BEARING HOUSINGS TO IMPELLER	14	75A34	75A34
22	IMPELLER CASE.....	1	900894021201	900894021401
23	SHAFT ASSEMBLY GROUP (SEAL VENTS).....	1	GAA81899	GAA81898
	SHAFT ASSEMBLY GROUP CONSISTS OF:			
	(1)ASSEMBLY SHAFT – LONG			
	(1) ASSEMBLY SHAFT – SHORT			
24	HOUSING--BEARING (DRIVE)			
	LIP SEAL.....	1	900894020801	900894020801
	MECHANICAL SEAL.....	1	205GAA006	205GAA006
25	DRIVE KEY	1	900891023101	900891023101
26	GREASE FITTING.....	2	900639910304	900639910304
27	GREASE FITTING CAP	2	40P58	40P58
+ 28	WAVY SPRING.....	2	78W65	78W65.
29	DRIVE COVER.....	1	900893021701	900893021701
30	SCREW--DRIVE COVER TO BEARING HOUSING ...	6	75A185N	75A185N
O 31	DRIVE SEAL	1	900639010802	900639010802
*+ 42	PLUGS REQUIRED WITH MECHANICAL SEAL.....	6	64AC1	64AC1
	SHIM--IMPELLER CASE			
	PAPER (.0015/.0020).....	0	202GAA732	202GAA732
	PAPER (.003).....	0	200GAA732	200GAA732
	ALUMINUM (.010).....	0	201GAA732	201GAA732
O	OVERHAUL KIT LIP SEAL.....	0	200GAA6010	200GAA6010
O	OVERHAUL KIT MECHANICAL SEAL.....	0	201GAA6010	201GAA6010
76	LOCTITE 620	1	25BC749	25BC749

* NOT SHOWN

o OVERHAUL KITS CONSIST OF BEARINGS, SEALS, GASKET, SHIMS, TAPER PINS AND BEARING RETAINER SCREWS.

+ MECHANICAL SEAL UNITS ONLY.

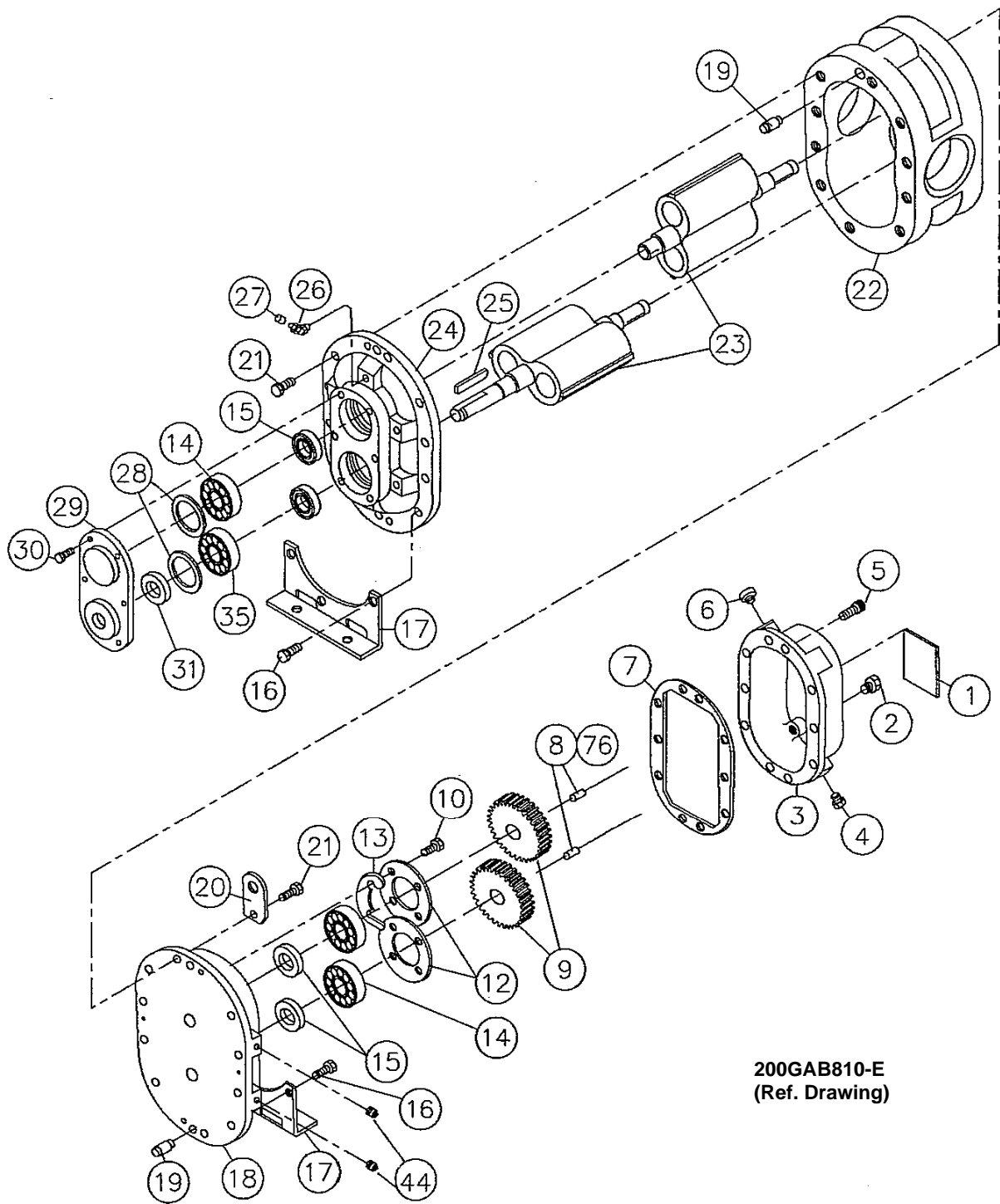

200GAB810-E
(Ref. Drawing)

Order by Part Number and Description. Reference Numbers are for your convenience only.

Ref. No.	Description	No. Req'd	MODEL GAB		
			Size-- 3H GABH_P_	Size -- 3M GABM_P_	Size -- 3L GABL_P_
1	NAMEPLATE	1	302GAA496	302GAA496	302GAA496
2	OIL LEVEL PLUG	2	64AC2	64AC2	64AC2
3	GEAR CASE	1	900873032901	900873032901	900873032901
4	DRAIN PLUG	1	64AC2	64AC2	64AC2
5	SCREW--GEAR CASE TO BEARING HOUSING	10	75LM224	75LM224	75LM224
6	BREATHER	1	5L306	5L306	5L306
o 7	GASKET GEAR CASE	1	200GAB715	200GAB715	200GAB715
o 8	TAPER PIN	2	62V58	62V58	62V58
9	TIMING GEAR GROUP	1	201GAB6008	201GAB6008	201GAB6008
o 10	SCREW--BEARING RETAINER TO BEARING HOUSING	8	75A185N	75A185N	75A185N
12	BEARING RETAINER	2	900883031401	900883031401	900883031401
+ 13	SHIM SET	1	900881032200	900881032200	900881032200
o 14	BEARING	3	12BA143	12BA143	12BA143
o 15	MAIN SEAL--PER APPLICATION BELOW				
	LIP SEAL VERSION	4	900891030601	900891030601	900891030601
	MECHANICAL SEAL VERSION	4	900871020003	900871020003	900871020003
16	SCREW--FOOT TO BEARING HOUSING	8	655ED050	655ED050	655ED050
17	FOOT GROUP				
	VERTICAL FOOT GROUP	1	GAB81903	GAB81903	GAB81903
	HORIZONTAL FOOT GROUP	1	GAB81904	GAB81904	GAB81904
18	HOUSING--BEARING (GEAR END)				
	LIP SEAL	1	900873033301	900873033301	900873033301
	MECHANICAL SEAL	1	900883030101	900883030101	900883030101
19	DOWEL PIN	4	62M48	62M48	62M48
20	LIFTING LUG	2	200GAA451	200GAA451	200GAA451
21	SCREW--BEARING HOUSINGS TO IMPELLER CASE	16	655ED040	655ED040	655ED040
22	IMPELLER CASE	1	900873034301	900873033801	900873034201
23	SHAFT ASSEMBLY GROUP	1	GAB81905	GAB81907	GAB81906
	SHAFT ASSEMBLY GROUP CONSISTS OF:				
	(1) ASSEMBLY SHAFT - LONG				
	(1) ASSEMBLY SHAFT - SHORT				
24	HOUSING--BEARING (DRIVE END)				
	LIP SEAL	1	900873033501	900873033501	900873033501
	MECHANICAL SEAL	1	900883030301	900883030301	900883030301
25	DRIVE KEY	1	900639910304	900639910304	900639910304
26	GREASE FITTING	2	40E9	40E9	40E9
27	GREASE FITTING CAP	2	40P58	40P58	40P58
+ 28	WAVY SPRING	2	900669170203	900669170203	900669170203
29	DRIVE COVER	1	900873033701	900873033701	900873033701
30	SCREW--DRIVE COVER TO BEARING HOUSING	6	75LM224	75LM224	75LM224
o 31	DRIVE SEAL	1	60DD725	60DD725	60DD725
o 35	BEARING DRIVE END DRIVE SHAFT	1	12BA153	12BA153	12BA153
*+ 42	PLUGS REQUIRED WITH MECHANICAL SEAL (Drive End) .	4	64AC1	64AC1	64AC1
44	SCREW--SET	2	76F92	76F92	76F92
*+ 46	PLUGS REQUIRED WITH MECHANICAL SEAL (Gear End)..	2	64AC2	64AC2	64AC2 .
	SHIM--IMPELLER CASE				
	PAPER (.0015/.0020)	0	202GAB732	202GAB732	202GAB732
	PAPER (.003)	0	200GAB732	200GAB732	200GAB732
	ALUMINUM (.010)	0	201GAB732	201GAB732	201GAB732
o	OVERHAUL KIT LIP SEAL	0	203GAB6010	203GAB6010	203GAB6010
o	OVERHAUL KIT MECHANICAL SEAL	0	204GAB6010	204GAB6010	204GAB6010
76	LOCTITE 620	1	25BC749	25BC749	25BC749

* NOT SHOWN

o OVERHAUL KITS CONSIST OF BEARINGS, SEALS, GASKET, SHIMS, TAPER PINS AND BEARING RETAINER SCREWS.

+ MECHANICAL SEAL UNITS ONLY.

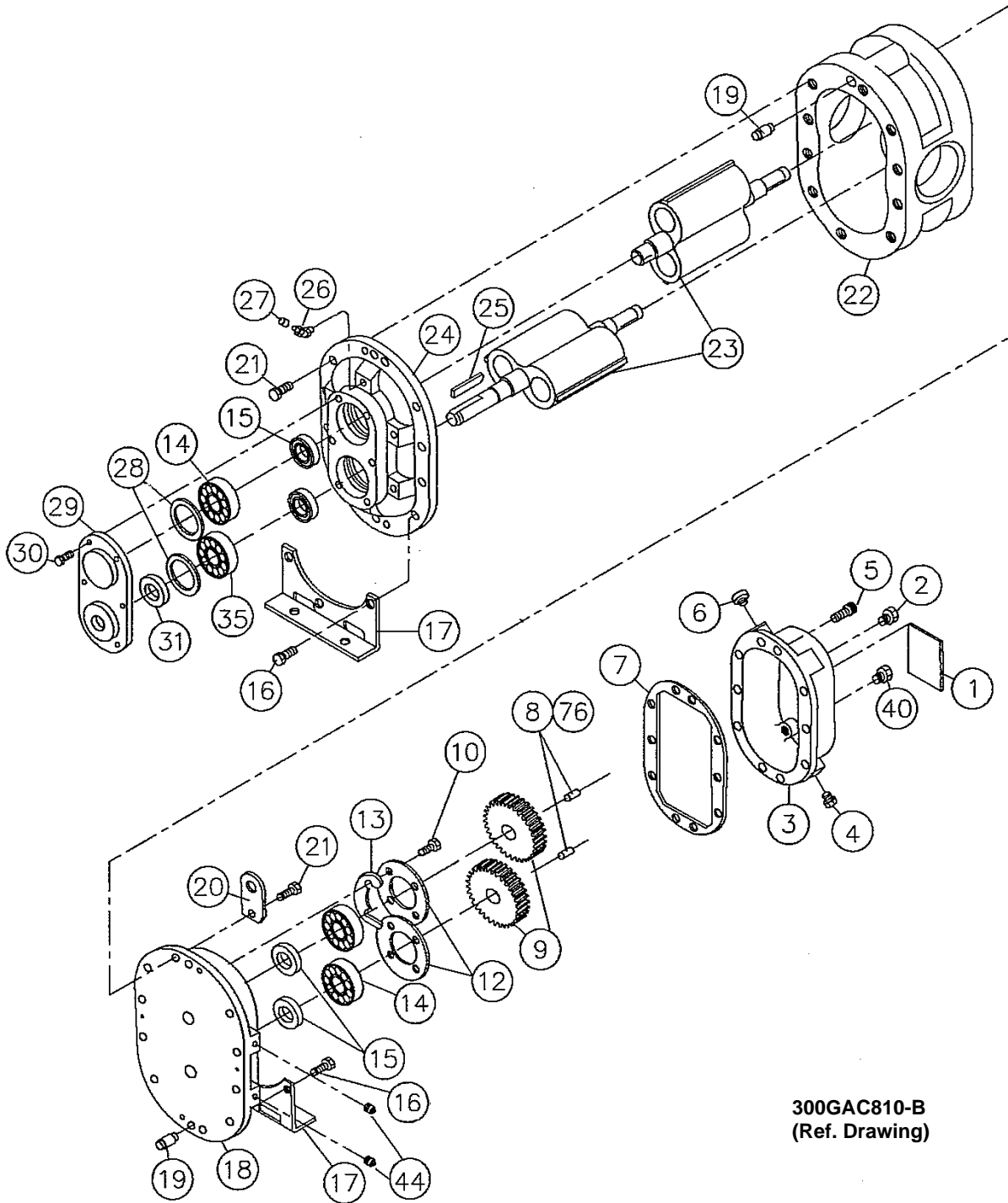

300GAC810-B
 (Ref. Drawing)

Order by Part Number and Description. Reference Numbers are for your convenience only.

Ref. No.	No. Description	Size -- 4H Req'd	Size -- 4M GACH_P_	MODEL GAC	
				Size -- 4L GACM_P_	GACL_P_
	1 NAMEPLATE	1	302GAA496	302GAA496	302GAA496
	2 PLUG FOR ALTERNATE OIL LEVEL CONN.....	1	64AC3	64AC3	64AC3
	3 GEAR CASE	1	900883040701	900883040701	900883040701
	4 DRAIN PLUG	1	64AC2	64AC2	64AC2
	5 SCREW--GEAR CASE TO BEARING HOUSING	12	75LM113	75LM113	75LM113
	6 BREATHER.....	1	5L306	5L306	5L306
O	7 GASKET GEAR CASE.....	1	200GAC715	200GAC715	200GAC715
O	8 TAPER PIN	2	62V58	62V58	62V58
	9 TIMING GEAR GROUP	1	200GAC6008	200GAC6008	200GAC6008
O	10 SCREW--BEARING RETAINER TO BEARING HOUSING.....	8	75A33N	75A33N	75A33N
	12 BEARING RETAINER.....	2	900883040201	900883040201	900883040201
+	13 SHIM SET	1	900881042900	900881042900	900881042900
O	14 BEARING.....	3	12BA144	12BA144	12BA144
O	15 MAIN SEAL--PER APPLICATION BELOW				
	LIP SEAL VERSION.....	4	60DD630	60DD630	60DD630
	MECHANICAL SEAL VERSION.....	4	900871020004	900871020004	900871020004
	16 SCREW--FOOT TO BEARING HOUSING	8	655ED050	655ED050	655ED050
	17 FOOT GROUP				
	VERTICAL FOOT GROUP	1	GAC81911	GAC81911	GAC81911
	HORIZONTAL FOOT GROUP.....	1	GAC81912	GAC81912	GAC81912
	18 HOUSING--BEARING (GEAR END)				
	LIP SEAL	1	900883040501	900883040501	900883040501
	MECHANICAL SEAL.....	1	900883041601	900883041601	900883041601
	19 DOWEL PIN	4	62M48	62M48	62M48
	20 LIFTING LUG	2	200GAA451	200GAA451	200GAA451
	21 SCREW--BEARING HOUSINGS TO IMPELLER CASE	16	655ED040	655ED040	655ED040
	22 IMPELLER CASE.....	1	900883042201	900883041801	900883042001
	23 SHAFT ASSEMBLY GROUP.....	1	208GAC4028	207GAC4028	206GAC4028
	SHAFT ASSEMBLY GROUP CONSISTS OF:				
	(1) ASSEMBLY SHAFT -- LONG				
	(1) ASSEMBLY SHAFT -- SHORT				
	24 HOUSING--BEARING (DRIVE END)				
	LIP SEAL	1	300GAC006	300GAC006	300GAC006
	MECHANICAL SEAL.....	1	900883041201	900883041201	900883041201
	25 DRIVE KEY 1 900639910304.....	1	900639910304	900639910304	900639910304
	26 GREASE FITTING	2	40E9	40E9	40E9
	27 GREASE FITTING CAP.....	2	40P58	40P58	40P58
+	28 WAVY SPRING.....	2	900669170304	900669170304	900669170304
	29 DRIVE COVER	1	900883040301	900883040301	900883040301
	30 SCREW--DRIVE COVER TO BEARING HOUSING	8	75LM113	75LM113	75LM113
O	31 DRIVE SEAL.....	1	60DD716	60DD716	60DD716
O	35 BEARING--ROLLER	1	12BA154	12BA154	12BA154
	40 GAUGE--OIL LEVEL.....	1	40P34	40P34	40P34
*+	42 PLUGS REQUIRED WITH MECHANICAL SEAL (Drive End)....	4	64AC1	64AC1	64AC1
	44 SCREW--SET	2	76F92	76F92	76F92
*+	46 PLUGS REQUIRED WITH MECHANICAL SEAL (Gear End)....	2	64AC2	64AC2	64AC2
	SHIM--IMPELLER CASE				
	PAPER (.0015/.0020).....	0	202GAC732	202GAC732	202GAC732
	PAPER (.003).....	0	200GAC732	200GAC732	200GAC732
	ALUMINUM (.010).....	0	201GAC732	201GAC732	201GAC732
O	OVERHAUL KIT LIP SEAL	0	202GAC6010	202GAC6010	202GAC6010
O	OVERHAUL KIT MECHANICAL SEAL.....	0	203GAC6010	203GAC6010	203GAC6010
	76 LOCTITE 620.....	1	25BC749	25BC749	25BC749

* NOT SHOWN

O OVERHAUL KITS CONSIST OF BEARINGS, SEALS, GASKET, SHIMS, TAPER PINS AND BEARING RETAINER SCREWS.

+ MECHANICAL SEAL UNITS ONLY.

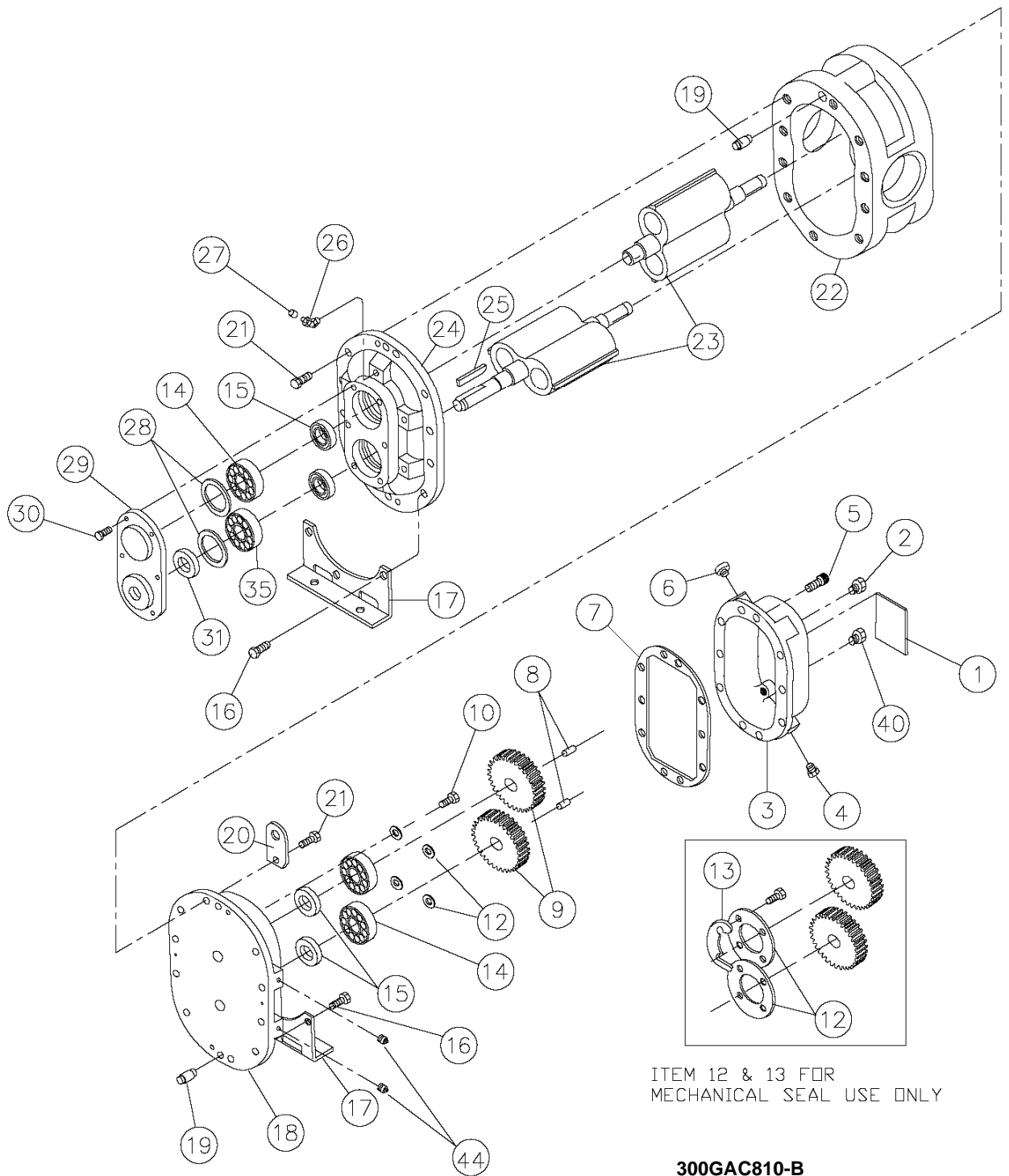

300GAC810-B
(Ref. Drawing)

Order by Part Number and Description. Reference Numbers are for your convenience only.

Ref. No.	Description	No. Req'd	MODEL GAE		
			Size -- 5H GAEH_P_	Size -- 5M GAEM_P_	Size -- 5L GAEL_P_
1	NAMEPLATE	1	301GAE496	301GAE496	301GAE496
2	PLUG FOR ALTERNATE OIL LEVEL CONN.....	1	64AC3	64AC3	64AC3
3	GEAR CASE	1	900883051001	900883051001	900883051001
4	DRAIN PLUG	1	64AC2	64AC2	64AC2
5	SCREW--GEAR CASE TO BEARING HOUSING	2	75LM113	75LM113	75LM113
6	VENT PLUG.....	1	5L306	5L306	5L306
O 7	GASKET GEAR CASE.....	1	200GAE715	200GAE715	200GAE715
O 8	TAPER PIN	2	62V58	62V58	62V58
9	TIMING GEAR GROUP	1	201GAE6008	201GAE6008	201GAE6008
+O 10	SCREW--BEARING RETAINER TO BEARING HOUSING.....	8	75A33	75A33	75A33
10	SCREW.....	4	75A33P	75A33P	75A33P
+ 12	BEARING RETAINER.....	2	900883050501	900883050501	900883050501
12		4	95A2	95A2	95A2
+ 13	SHIM SET	1	900881052900	900881052900	900881052900
O 14	BEARING	3	8500397	8500397	8500397
O 15	MAIN SEAL--PER APPLICATION BELOW				
	LIP SEAL VERSION.....	4	60DD714	60DD714	60DD714
	MECHANICAL SEAL VERSION.....	4	900871020005	900871020005	900871020005
16	SCREW--FOOT TO BEARING HOUSING	8	655ED050	655ED050	655ED050
17	FOOT GROUP				
	VERTICAL FOOT GROUP	1	GAE81922	GAE81922	GAE81922
	HORIZONTAL FOOT GROUP.....	1	GAE81923	GAE81923	GAE81923
18	HOUSING--BEARING (GEAR END)				
	LIP SEAL	1	900883052101	900883052101	900883052101
	MECHANICAL SEAL.....	1	900883050301	900883050301	900883050301
19	DOWEL PIN	4	62M48	62M48	62M48
20	LIFTING LUG.....	2	200GAA451	200GAA451	200GAA451
21	SCREW--BEARING HOUSINGS TO IMPELLER CASE	24	655ED040	655ED040	655ED040
22	IMPELLER CASE.....	1	900883051701	900883051801	900883051901
23	SHAFT ASSEMBLY GROUP.....	1	207GAE4028	206GAE4028	205GAE4028
	SHAFT ASSEMBLY GROUP CONSISTS OF:				
	(1) ASSEMBLY SHAFT -- LONG				
	(1) ASSEMBLY SHAFT -- SHORT				
24	HOUSING--BEARING (DRIVE END)				
	LIP SEAL	1	206GAE006	206GAE006	206GAE006
	MECHANICAL SEAL.....	1	207GAE006	207GAE006	207GAE006
25	DRIVE KEY	1	900639910305	900639910305	900639910305
26	GREASE FITTING	2	911659990606	911659990606	911659990606
27	GREASE FITTING CAP.....	2	40P58	40P58	40P58
+ 28	WAVY SPRING.....	2	900669170405	900669170405	900669170405
29	DRIVE COVER	1	900883050401	900883050401	900883050401
30	SCREW--DRIVE COVER TO BEARING HOUSING	8	75LM113	75LM113	75LM113
O 31	DRIVE SEAL.....	1	60DD726	60DD726	60DD726
O 35	BEARING--ROLLER.....	1	12BA155	12BA155	12BA155
40	GAUGE--OIL LEVEL.....	1	40P34	40P34	40P34
*+ 42	PLUGS REQUIRED WITH MECHANICAL SEAL (Drive End)....	4	64AC1	64AC1	64AC1
44	SCREW--SET	4	76F92	76F92	76F92
*+ 46	PLUGS REQUIRED WITH MECHANICAL SEAL (Gear End)....	4	64AC2	64AC2	64AC2
	SHIM--IMPELLER CASE				
	PAPER (.0015/.0020).....	0	202GAE732	202GAE732	202GAE732
	PAPER (.003).....	0	200GAE732	200GAE732	200GAE732
	ALUMINUM (.010).....	0	201GAE732	201GAE732	201GAE732
O	OVERHAUL KIT LIP SEAL	0	200GAE6010	200GAE6010	200GAE6010
O	OVERHAUL KIT MECHANICAL SEAL.....	0	203GAE6010	203GAE6010	203GAE6010
76	LOCTITE 620.....	1	25BC749	25BC749	25BC749

* NOT SHOWN

o OVERHAUL KITS CONSIST OF BEARINGS, SEALS, GASKET, SHIMS, TAPER PINS AND BEARING RETAINER SCREWS.

+ MECHANICAL SEAL UNITS ONLY.

**SUTORBILT BLOWERS
SUTORBILT LEGEND SERIES****GENERAL PROVISIONS AND LIMITATIONS**

Gardner Denver (the "Company") warrants to each original retail purchaser ("Purchaser") of its new products from the Company or its authorized distributor that such products are, at the time of delivery to the Purchaser, made with good material and workmanship. No warranty is made with respect to:

1. Any product which has been repaired or altered in such a way, in the Company's judgment, as to affect the product adversely.
2. Any product which has, in the Company's judgment been subject to negligence, accident, improper storage, or improper installation or application.
3. Any product which has not been operated or maintained in accordance with normal practice and with the recommendations of the Company.
4. Components or accessories manufactured, warranted and serviced by others.
5. Any reconditioned or prior owned product.

Claims for items described in (4) above should be submitted directly to the manufacturer.

WARRANTY PERIOD

The Company's obligation under this warranty is limited to repairing or, at its option, replacing, during normal business hours at an authorized service facility of the Company, any part which in its judgment proved not to be as warranted within the applicable Warranty Period as follows.

BARE BLOWERS

Basic bare blowers, consisting of all parts within, are warranted for 18 months from date of initial use or 24 months from date of shipment to the first purchaser, whichever occurs first.

Any disassembly or partial disassembly of the blower, or failure to return the "unopened" blower per Company instructions, will be cause for denial of warranty.

OTHER COMPONENTS

All other components are warranted for 12 months from date of initial use or 18 months from date of shipment to first purchaser, whichever comes first.

The Company reserves the right to withdraw the Warranty where evidence indicates application outside the stated performance area, or where there is evidence of abuse.

LABOR TRANSPORTATION AND INSPECTION

The Company will provide labor, by Company representative or authorized service personnel, for repair or replacement of any product or part thereof which in the

Company's judgment is proved not to be as warranted. Labor shall be limited to the amount specified in the Company's labor rate schedule.

Labor costs in excess of the Company rate schedule amounts or labor provided by unauthorized service personnel is not provided for by this warranty.

Transportation of Company's choice, within the continental United States, is covered by this warranty for replacement of any blower which in the Company's judgment proved not to be as warranted. For user locations outside the continental United States, the Company will provide transportation, by the carrier of its choice to and from the nearest Authorized Distributor and the Company's designated facility. The Company may require the return of any blower claimed not to be as warranted to one of its facilities as designated by the Company, transportation prepaid by Purchaser, to establish a claim under this warranty.

Replacement parts provided under the terms of the warranty are warranted for the remainder of the Warranty Period of the product upon which installed to the same extent as if such parts were original components thereof.

DISCLAIMER

THE FOREGOING WARRANTY IS EXCLUSIVE AND IT IS EXPRESSLY AGREED THAT, EXCEPT AS TO TITLE, THE COMPANY MAKES NO OTHER WARRANTIES, EXPRESSED, IMPLIED OR STATUTORY, INCLUDING ANY IMPLIED WARRANTY OF MERCHANTABILITY.

THE REMEDY PROVIDED UNDER THIS WARRANTY SHALL BE THE SOLE, EXCLUSIVE AND ONLY REMEDY AVAILABLE TO PURCHASER AND IN NO CASE SHALL THE COMPANY BE SUBJECT TO ANY OTHER OBLIGATIONS OR LIABILITIES. UNDER NO CIRCUMSTANCES SHALL THE COMPANY BE LIABLE FOR SPECIAL, INDIRECT, INCIDENTAL OR CONSEQUENTIAL DAMAGES, EXPENSES, LOSSES OR DELAYS HOWSOEVER CAUSED.

No statement, representation, agreement, or understanding, oral or written, made by any agent, distributor, representative, or employee of the Company which is not contained in this Warranty will be binding upon the Company unless made in writing and executed by an officer of the Company.

This warranty shall not be effective as to any claim which is not presented within 30 days after the date upon which the product is claimed not to have been as warranted. Any action for breach of this warranty must be commenced within one year after the date upon which the cause of action occurred.

Any adjustment made pursuant to this warranty shall not be construed as an admission by the Company that any product was not as warranted.

Gardner Denver[®]

For additional information contact your local representative or
Gardner Denver, 1800 Gardner Expressway, Quincy, IL 62305
Customer Service Department
Telephone: (800) 682-9868 Fax: (217) 221-8780
Sales and Service in all major cities.
www.gardnerdenver.com pd.blowers@gardnerdenver.com

© 2007 Gardner Denver, Inc. Litho in U.S.A.



Member



This document was created with Win2PDF available at <http://www.win2pdf.com>.
The unregistered version of Win2PDF is for evaluation or non-commercial use only.
This page will not be added after purchasing Win2PDF.

Installation & Maintenance Instructions

ASCO® TRIPPOINT® SWITCH UNITS
TWO-STAGE FIXED DEADBAND SWITCH UNITS

PC-SERIES

OPEN-FRAME TYPE, GENERAL PURPOSE, OR WATERTIGHT SWITCH ENCLOSURE

Form No.P7050R1

DESCRIPTION

The PC-Series Two-Stage Fixed Deadband Switch Units are used with transducer units to make Tripoint Pressure Switches or Temperature Switches. The switch units are made of aluminum alloy and designed for rugged use. The switch unit may be provided as open-frame type or with a general purpose or watertight enclosure. All wiring terminals, adjustments, and visual scales are accessible from the front of the switch.

The switch may be supplied as a complete unit, with the switch unit and transducer unit completely assembled. The components may be separate units to be assembled upon installation. The two-stage switch unit has two adjusting nuts which provide independent adjustment of the two electrical switches. Each switch has an adjustable (set) point and non-adjustable (reset) point. The difference between the set point and the reset point is the fixed deadband. The actuation points of the electrical switches cannot be identical but require a minimum separation. The switch assembly can be mated with a wide selection of pressure and temperature transducers to cover a broad range of pressure, fluids, and temperatures. The switch will control electrical circuits in response to change in pressure and temperature signals.

IMPORTANT: These instructions cover the installation and use of this switch on pressure and temperature transducers. Select the paragraphs that apply to your particular installation and application. The word *signal* is used in place of pressure or temperature changes.

INSTALLATION

Check the nameplate for the correct catalog number, pressure range, temperature range, media, and proof pressure or rated overrange temperature. Never apply incompatible fluids or exceed the pressure or temperature rating of the switch. Installation and inspection to be performed by qualified personnel.

Nameplates are located on the switch (or switch cover) and on the bottom of the transducer. Check to be sure the third digit in each number is the same. If not, the unit should not be used (Refer to Figure 4).

IMPORTANT: All internal adjustments have been made at the factory. Any adjustment, alteration or repair to the internal parts of the switch other than stated herein voids all warranties. The signal setting adjustments required are made by the adjusting two nuts on the top of the switch.

Temperature Limitations

Switch ambient temperature limits are -4°F (-20°C) to 122°F (50°C). To determine fluid temperature limitations, see Form No. P7051 for pressure transducer catalog numbers and construction materials, then refer to chart below.

TRANSDUCER CONSTRUCTION MATERIALS	RATINGS FLUID TEMPERATURE
Buna N or Neoprene	-4°F (-20°C) to 180°F (82°C)
VITON*	-4°F (-20°C) to 250°F (121°C)
316 Stainless Steel	-50°F (-45°C) to 300°F (149°C)
All Nylon	Maximum 180°F (82°C)
All Nylon For Water Service	Maximum 130°F (55°C)

For stream service, the fluid temperature with a pigtail (siphon tube or condensate loop) installed directly into the transducer will be below 180°F (82°C).

Assembly Of Switch And Transducer Units (Refer to Figure 4)

IMPORTANT: The switch unit and transducer unit may be purchased as a complete assembly or as separate units. If separate units are purchased, refer to Form No. P7051 for a complete listing of switch unit and transducer unit combinations. Form No. P7051 is provided to ensure that the proper switch unit is assembled to the proper transducer unit.

Pay careful attention to exploded view provided in Figure 4 for assembly of switch unit and transducer unit. Proceed in the following manner:

CAUTION: The third digit in the catalog number on both the switch unit and the transducer unit must be identical. If not, do not assemble to each other. If the same, proceed.

1. Remove bolts (4) from base of switch unit. On general purpose or raintight constructions, remove switch cover.
2. Remove instruction label and pressure or temperature switch range scale from the transducer unit.
3. Place transducer unit on base of switch unit and assemble. Start bolts (4) approximately two turns by hand to avoid the possibility of cross threading. After initial engagement, torque bolts (4) in a crisscross manner to 80 ± 10 in-lbs [9.0 ± 1.1 Nm].
4. Remove backing paper from range scale and install on the front of the switch body over the opening for the adjusting indicator point.

Positioning

Switch may be mounted in any position.

Mounting

Refer to Figures 1 and 2 for mounting.

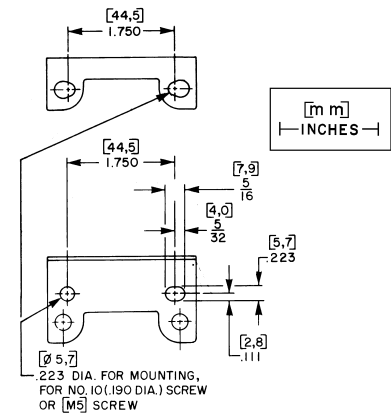

Figure 1. Optional Mounting Bracket

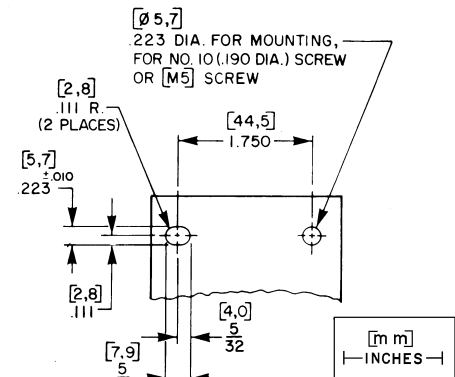

Figure 2. General Purpose Enclosure

Piping/Tubing (Pressure Transducer)

Adequate support of piping and proper mounting of switch should be made to avoid excessive shock or vibration. To minimize the effect of vibration on a switch, mount perpendicular to vibration. Connect piping or tubing to switch at base of transducer. It is recommended that flexible tubing be used whenever possible. Apply pipe compound sparingly to male pipe threads only. If applied to female threads, it may enter the transducer and cause operational difficulty. Avoid pipe strain on switch by properly supporting and aligning piping. When tightening pipe, do not use switch as a lever. Wrenches applied to transducer body or piping are to be located as close as possible to connection point.

IMPORTANT: For steam service, install a condensate loop (pigtail or steam syphon tube) directly into the pressure transducer.

CAUTION: To avoid damage to the transducer body, DO NOT OVERTIGHTEN PIPE CONNECTIONS. If TEFLON* tape, paste or similar lubricant is used, use extra care due to reduced friction.

IMPORTANT: To eliminate undesirable pressure fluctuations in the system, install a surge suppressor.

Wiring

Wiring must comply with local codes and the National Electrical Code. The general purpose switch enclosure is provided with a 7/8" diameter hole to accommodate 1/2" electrical hub or connector. The watertight switch enclosure has a 1/2" conduit hub. It is recommended that a flexible conduit connection be used. If rigid conduit is used, do not consider it or use it as a means of supporting (mounting). Use No. 14 AWG copper wire rated for 60°C minimum. Electrical connections are .187" (3/16) spade type quick connect terminals. Snap switches accept MOLEX INCORPORATED's connector (Order No. 05-06-0304) and connector housing (Order No. 06-02-3031).

IMPORTANT: Electrical load must be within range stated on nameplate. Failure to stay within the electrical range of the switch rating may result in damage to or premature failure of electrical switch.

CAUTION: Do not exert excessive screw driver force on snap switch when making terminal connections. When connections are made, be sure there is no stress on the wire leads. Either condition may cause malfunction of switch.

ELECTRICAL RATINGS		
Switch Unit	Ratings for Limit Controls and Pressure Operated Switches	Ratings for Industrial Controls and Temperature Indicating and Regulating Equipment
Standard Switch Rating	2 Amps Res., 125/250 VAC 1/8 HP 125 VAC 1/4 HP 250 VAC 1/2 Amp Res., 125 VDC 1/4 Amp Res., 250 VDC	10 Amps Res., 125/250 VAC 1/3 HP 125/250 VAC 1/2 Amp 125 125 VDC 1/4 Amp 250 VDC 125 VA PILOT DUTY 120/240 VAC

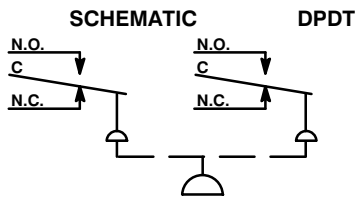

ELECTRICAL TERMINALS

Electrical terminals are .187" spades arranged as:

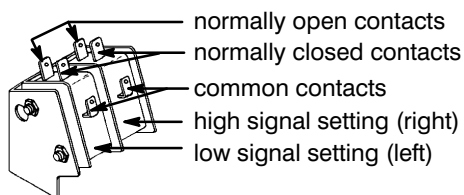

*DuPont's Registered Trademark

INSTALLATION OF TEMPERATURE TRANSDUCERS

Direct Probe

The direct probe (local) temperature transducer is provided with 1/2" NPT connection. When installing, do not use switch unit as a lever for tightening. Use wrenching flats provided at base of transducer for tightening.

Capillary and Bulb

The capillary and bulb (remote) temperature transducers are provided with a length of capillary and a 3/8" diameter sensing bulb.

CAUTION: Do not bend capillary at sharp angles. For proper operation, be sure sensing bulb is completely immersed in fluid and not in contact with heating element or anything that would directly affect the temperature of the fluid being sensed.

Thermal Well (Optional Feature)

A thermal well may be used for capillary and bulb (remote) or direct probe (local) temperature transducers. The thermal well affords protection for the sensing bulb and allows removal of the sensing bulb while maintaining a pressure tight vessel. When installing sensing bulb in thermal well, be sure that it is fully inserted. Where a thermal well already exists, jam nuts may be obtained to adapt the capillary and bulb to the existing thermal well. The existing thermal well must be for a 3/8" diameter sensing bulb.

Union Connector (Optional Feature)

A union connector will allow direct mounting of the sensing bulb in the fluid being controlled. Install union into piping connection before tightening union onto bulb. For maximum performance, the bulb should be inserted in the union connection so that the end of the sensing bulb is even with the end of the union connector nut. Do not apply excessive torque when tightening union connector nut.

Adjustment (Signal Setting) of Two-Stage Fixed Deadband Switch

When facing switch in the upright position, the adjusting nut on the highest point controls the high signal setting. The adjusting nut at the lowest point controls low signal setting (Refer to Figure 3). To make adjustments, a 1/4" wrench and a pressure or temperature gage (within suitable range) are required. If electrical connection (to line of final application) of the switch is not desirable, a battery-powered test lamp or ohmmeter may be used. Pressure or temperature range scales may be used for initial signal settings. These will be accurate within 5%. Adjust switch until pointer is in the middle of the solid red line below the desired range. For exact signal settings, proceed as follows:

Adjustment (Signal Setting) of Normally Closed or Normally Open Switch, Increasing Signal (Refer to Figure 3)

1. If the switch is in the line of final application when adjustment (signal setting) is made, be sure switch can be test operated without affecting other equipment.
2. On general purpose and watertight constructions, remove switch cover.
3. Turn high signal adjusting nut until high signal setting indicator is fully up. Then turn low signal adjusting nut until low signal setting indicator is fully up. Use a 1/4" wrench for adjusting nuts.

CAUTION: Adjusting nut will turn easily until it hits a stop. Do not over torque. Over torquing may cause damage.

4. Follow the steps in the chart below to make signal settings. Test one snap switch at a time. Be sure to start with low signal side.

MAINTENANCE

⚠ WARNING: To prevent the possibility of personal injury or property damage, turn off electrical power and depressurize switch unit before inspection or removal.

IMPORTANT: Switch is not field repairable. The switch must be returned to the factory (Automatic Switch Company, Florham Park, New Jersey) or serviced only by an authorized factory representative. Address all service inquiries to Automatic Switch Company, 50–60 Hanover Road, Florham Park, New Jersey 07932, Valve Service Department. The only maintenance which may be performed on the switch is changing the setting of the adjusting nuts and replacement of the transducer unit. Replacement of transducer should be done only if external leakage is evident.

Adjustment Procedures	NORMALLY CLOSED		NORMALLY OPEN	
	Switch Terminal	Test Lamp On–Off	Switch Terminal	Test Lamp On–Off
1. Starting with zero signal, connect test lamp to common.	NC	On (Closed Circuit)	NO	Off (Open Circuit)
2. Apply desired actuation signal. Then back off signal adjusting nut until switch actuates.	NC	Off (Open Circuit)	NO	On (Closed Circuit)
3. Lower signal to check reactuation signal.	NC	On (Closed Circuit)	NO	Off (Open Circuit)

5. To adjust high signal setting, repeat steps of adjustment in chart above.
6. Cycle between actuation and reactuation signals and make minor adjustments to nuts as required to achieve the exact signal setting.
7. After settings have been made, make permanent electrical connections.

Adjustment (Signal Setting) of Normally Closed or Normally Open Switch, *Decreasing Signal* (Refer to Figure 3)

1. If the switch is in the line of final application when adjustment (signal setting) is made, be sure switch can be test operated without affecting other equipment.
2. On general purpose and watertight constructions, remove switch cover.
3. Turn low signal adjusting nut until low signal setting indicator is fully down. Then turn high signal adjusting nut until high signal indicator is fully down. Use a 1/4" wrench for adjusting nuts.

CAUTION: Adjusting nut will turn easily until it hits a stop. Do not over torque. Over torquing may cause damage.

4. Follow the steps in the chart below to make signal settings. Test one snap switch at a time. Be sure to start with the high signal side.

Adjustment Procedures	NORMALLY CLOSED		NORMALLY OPEN	
	Switch Terminal	Test Lamp On–Off	Switch Terminal	Test Lamp On–Off
1. Starting with initial signal above desired actuation setting, connect test lamp to common.	NC	Off (Open Circuit)	NO	On (Closed Circuit)
2. Decrease signal to desired actuation. Then advance adjusting nut until switch actuates.	NC	On (Closed Circuit)	NO	Off (Open Circuit)
3. Increase signal to check reactuation signal.	NC	Off (Open Circuit)	NO	On (Closed Circuit)

5. To adjust low signal setting, repeat steps of adjustment in chart above.
6. Cycle between actuation and reactuation signals and make minor adjustments to nuts as required to achieve the exact signal setting.
7. After settings have been made, make permanent electrical connections.

Testing of Installation

If the adjustment of the switch has been made outside of the line of final application, the switch should be retested when installed in the line of final application. Follow adjustment instructions. Be sure switch can be test operated without affecting other equipment.

Preventive Maintenance

- While in service, operate the switch (cycle between desired signals) at least once a month to insure proper operation. If necessary, electrical wiring and pipe connection should be made so that switch can be test operated without affecting other equipment.
- Periodic inspection of the switch, external surfaces only, should be carried out. Switch should be kept clean and free from paint, foreign matter, corrosion, icing, and freezing conditions.
- Keep the medium entering the transducer as free as possible from dirt and foreign material.

Causes of Improper Operation

Switch will not actuate or actuates and reactuates undesirable.

- **Incorrect Electrical Connection:** Check leads to switch. Be sure they are properly connected. Switch is marked *NO* for Normally Open, *NC* for Normally Closed and *C* for Common.
- **Faulty Control Circuit:** Check electrical power supply to switch. Check for loose or blown fuses, open–circuited or grounded wires, loose connections at terminal block or switch. See nameplate for electrical rating and range.
- **Incorrect Adjustment:** Check adjustment nuts for proper setting. Refer to adjustment instructions.
- **External Leakage:** Check to see that bolts (4) holding transducer to pressure switch are properly torqued to 80 ± 10 in–lbs [9.0 ± 1.1 Nm]. If bolts are tight and leakage is still evident, replace transducer. Refer to paragraph on *Assembly of Switch Unit and Transducer Unit*.
- **Excessive Vibration or Surges Causing Switch to Actuate and Reactuate:** Check for fluctuations in system and install pressure surge suppressor. Check switch mounting and be sure there is no excessive vibration.
- **Incorrect Pressure:** Check pressure in system with suitable pressure gage. Pressure must be within range specified on nameplate.
- **Incorrect Temperature:** Check temperature in system with suitable thermometer. Temperature must be within range specified on nameplate. Check location of capillary and bulb for incorrect mounting. Refer to paragraphs on *Installation of Temperature Transducers*.

If the operation of the switch cannot be corrected by the above means, the entire switch unit should be replaced or an authorized factory representative consulted.

FOR SERVICE, REPLACEMENT, OR NEW TRANSDUCER

Consult Factory, or Authorized Factory Representative or Distributors

ORDERING INFORMATION

For Two–Stage Fixed Deadband Switch or New Transducer When Ordering, Specify Catalog Numbers, Fluid, Pressure Range, Temperature Range, Serial Numbers, and Proof Pressure or Rated Overrange Temperature.

NAMEPLATES ARE LOCATED ON SWITCH COVER AND BOTTOM OF TRANSDUCER.

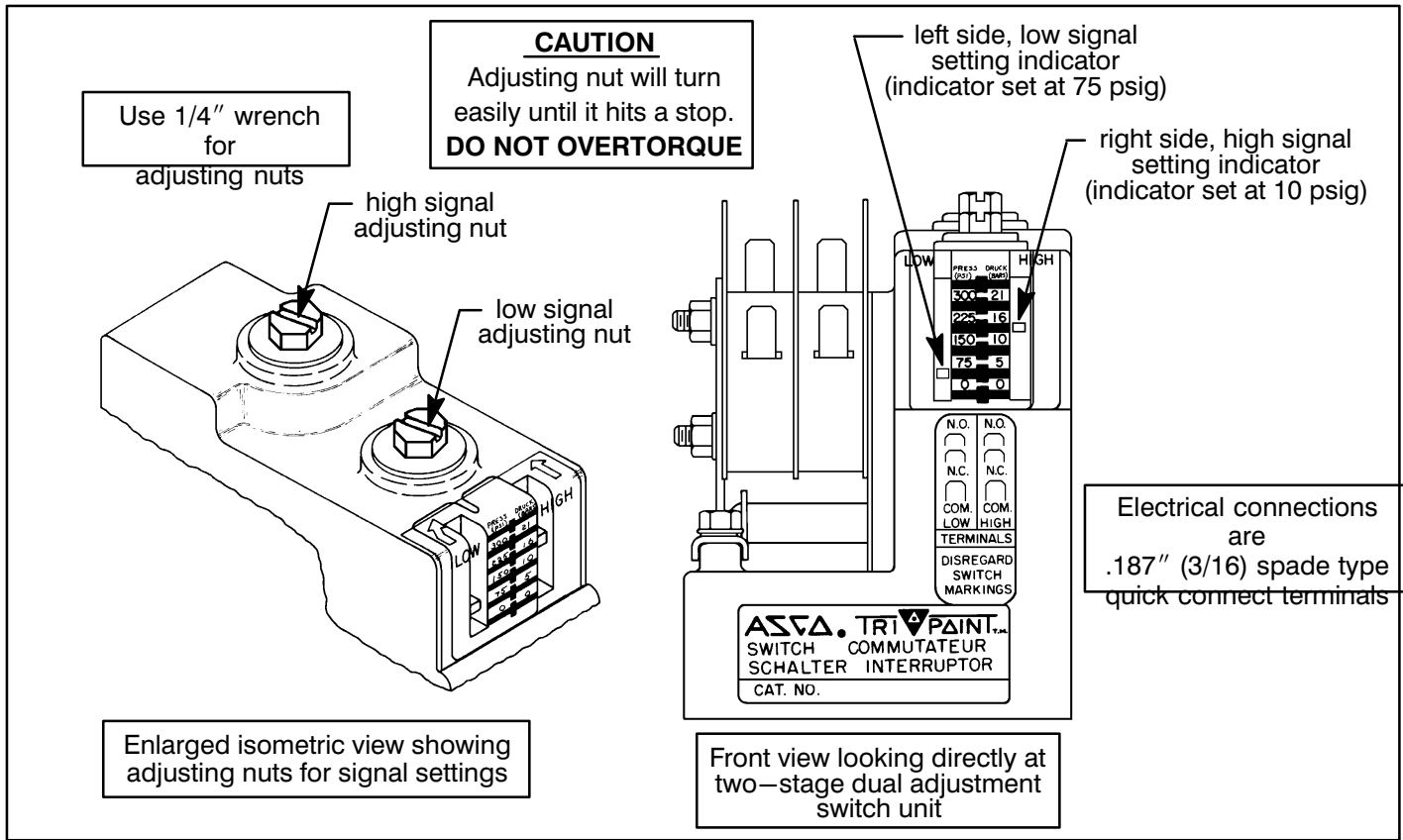

Figure 3. Adjustment (Signal Setting) of Two-Stage Dual Adjustment Switch Unit.

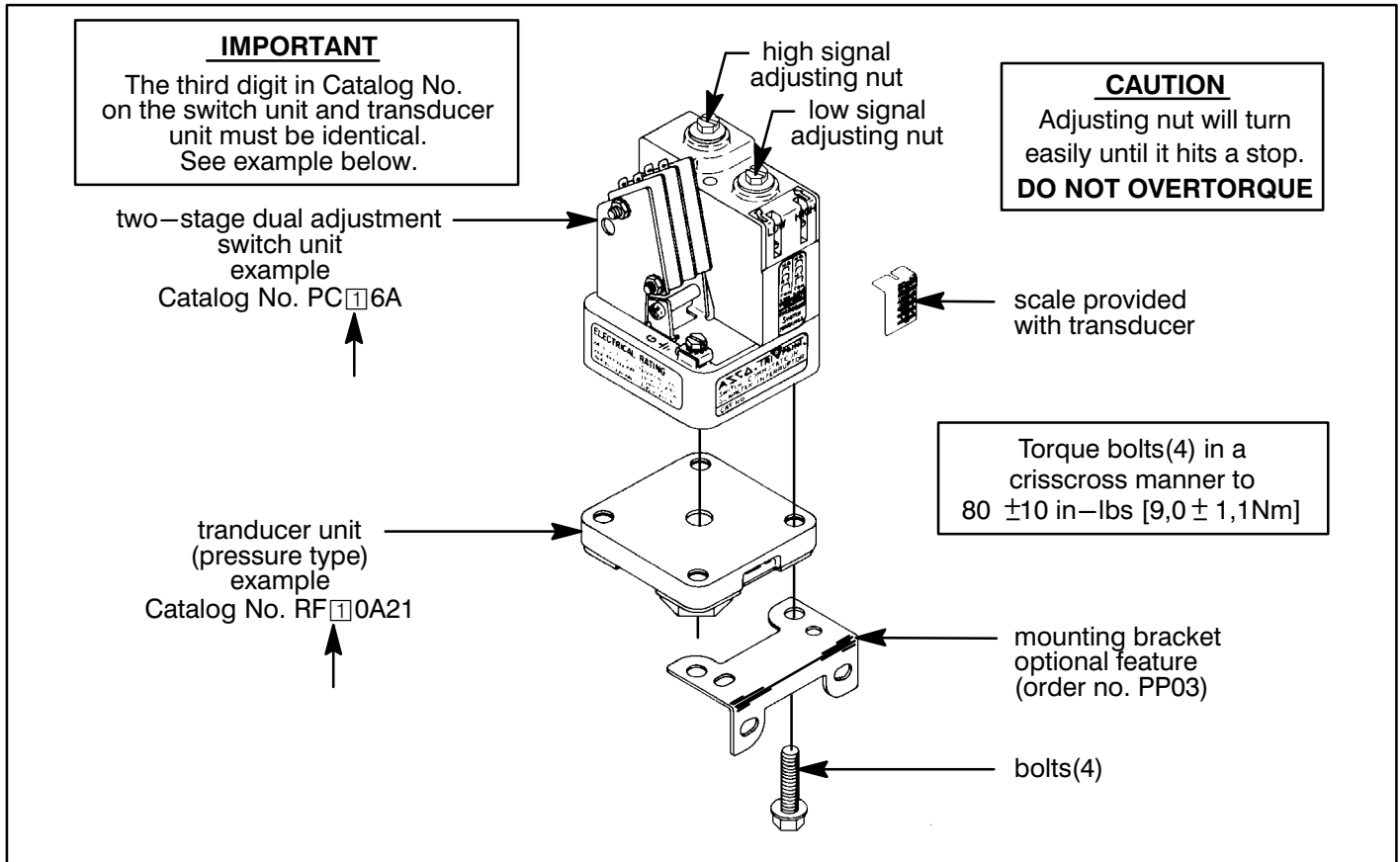

Figure 4. Open Frame Switch (Switch Unit and Transducer Unit to be assembled).