



REVERSE AIR - MODEL SWF DUST COLLECTOR BAGHOUSE

INSTRUCTION, OPERATIONS & MAINTENANCE MANUAL

CLEAN AIR MANAGEMENT COMPANY, INC.

8224 Nieman Road • Lenexa, Kansas 66214 Phone: 913-831-0740 Fax: 913-831-9271

TABLE OF CONTENTS

OPERATING PRINCIPLE & SECTION/PARTS DETAIL.....	1-1
RECEIVING & INSPECTION OF UNIT	2-1
ON SITE STORAGE RECOMMENDATIONS	3-1
SETTING UP YOUR UNIT.....	4-1
BAG & CAGE INSTALLATION	5-1
START-UP CHECK LIST	6-1
START-UP DUST CONTROL SYSTEMS	7-1
SHUTDOWN PROCEDURES.....	8-1
TROUBLE SHOOTING THE DUST COLLECTOR.....	9-1
TOUBLESHOOTING THE CLEANING MECHANISM.....	10-1
SAFETY RECOMMENDATIONS.....	11-1
ROUTINE MAINTENANCE.....	12-1
COMPONENT IOM MANUALS	13-1

OPERATION PRINCIPLE

- A. Solids laden air or gases enter the unit at the hopper or housing inlet.
- B. Air passes through the filter media.
- C. Solids are retained on the filter media surface.
- D. Cleaning consists of a rotating sweep arm with nozzles positioned over the bags that continuously blows a reverse flow of air into the bags.
 - 1. This momentarily takes a row of bags off stream through pressure reversal.
 - 2. Flexing filter bags.
 - 3. Solids are released to fall towards hopper and through rotary valve or other discharge equipment.

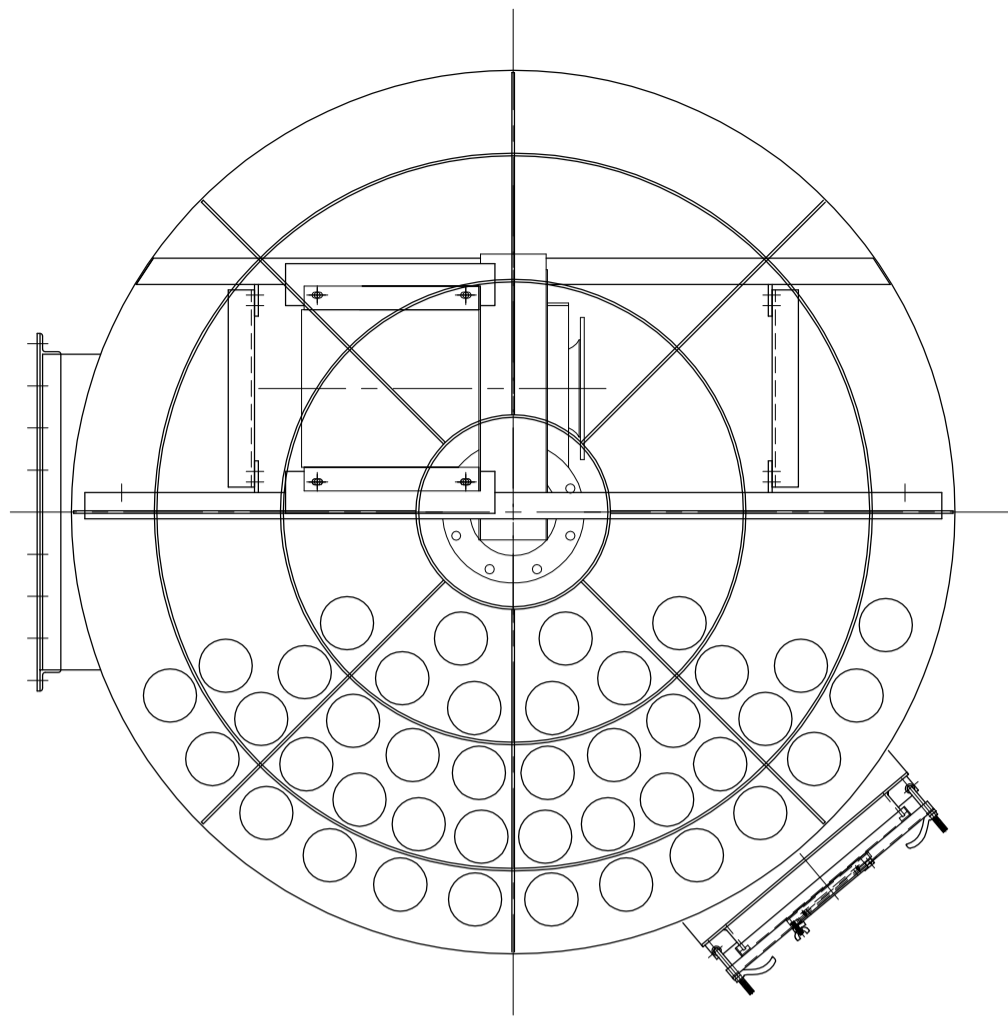

VIEW A-A

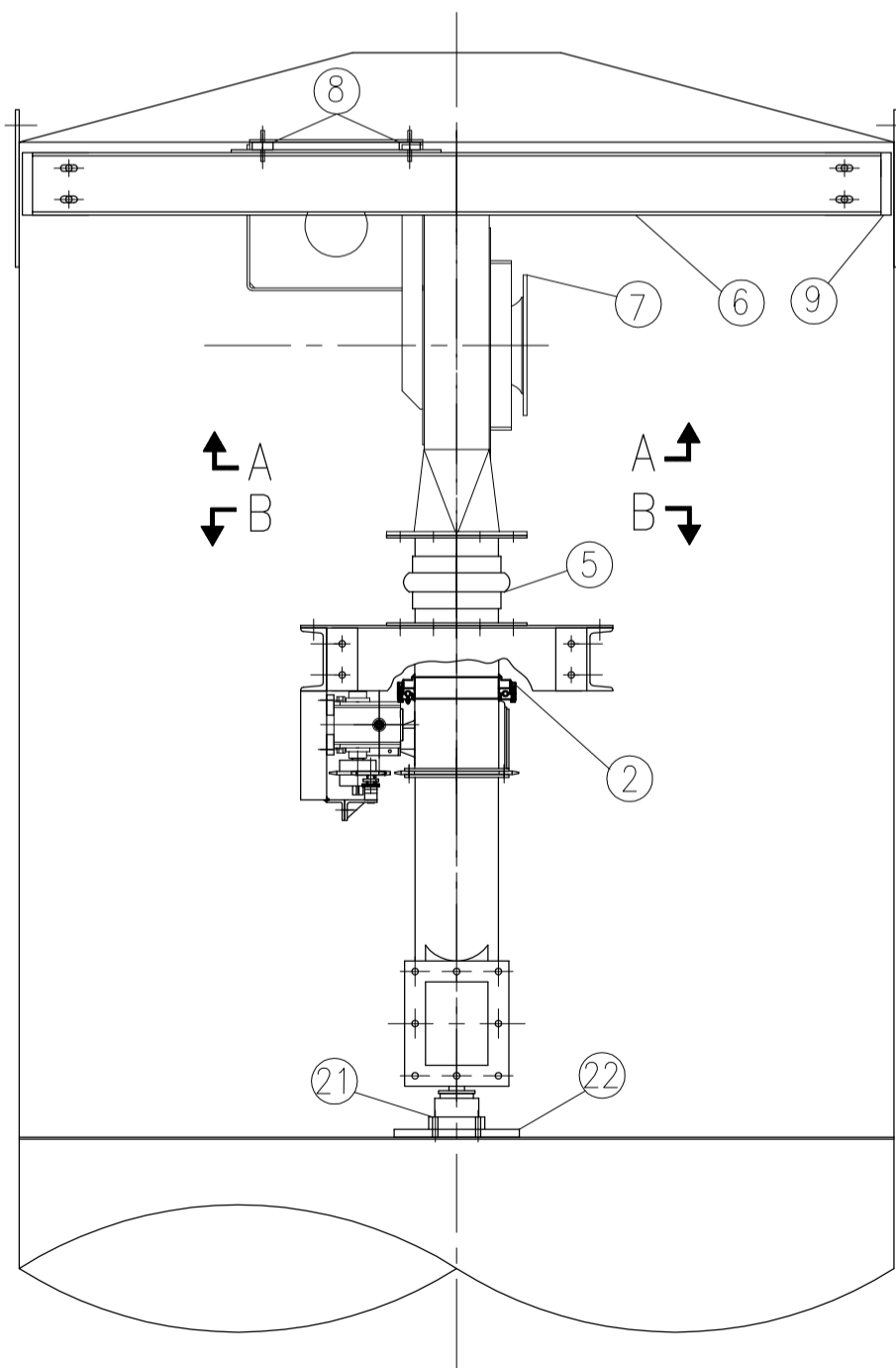

TYPICAL REVERSE AIR SWEEP
ARM DRIVE & FAN ARRANGEMENT
VIEW A-A



Camcorp Reverse Air Components		
Item	Quantity	Description
1A	1	Sweep Arm (Size Determined by Unit)
1B	1	Sweep Arm (Size Determined by Unit)
2	1	8" OD Rotary Spool Section
3	1	8" OD Arm Rotation Support
4	1	8" OD Fan Exhaust Air Stub
5	1	8" Straight Rubber Hump
6	1	Fan Channel Support
7	1	Reverse Air Fan (Size Determined by Unit Size)
8	4	Vibration Isolation Supports
9	2	Fan Support Wall Bracket
10	4	Drive Mount Table Wall Brackets
11	2	Drive Mount Table Support Channel
12	1	50TTA2635 x 1" Sprocket & TTA35BS x 1 " Torque Limiter Clutch
13	1	50A58 Drive Sprocket
14	1	Roller Chain Tensioner
15	1	206 Gearbox Drive Shaft
16	3	Motor, ½ HP, TEFC 1,800 RPM, 56C, 208-230/460/3/60
17	1	Primary Gear Reducer, 133Q56R20, 20:1 Ratio
18	1	Secondary Gear Reducer, 206Q56L40, 40:1 Ratio
19	1	Bracket Kit, 206S-BK (Secondary Reducer)
20	1	Drive Mount Support Table
21	1	4-Bolt Flange Thrust Bearing, 1 ½"
22	1	Bearing Mounting Plate

Visit our Website at: www.camcorpinc.com

CLEAN AIR MANAGEMENT COMPANY, INC.

8224 Nieman Road • Lenexa, Kansas 66214 • Phone 913-831-0740 • Fax 913-831-9271

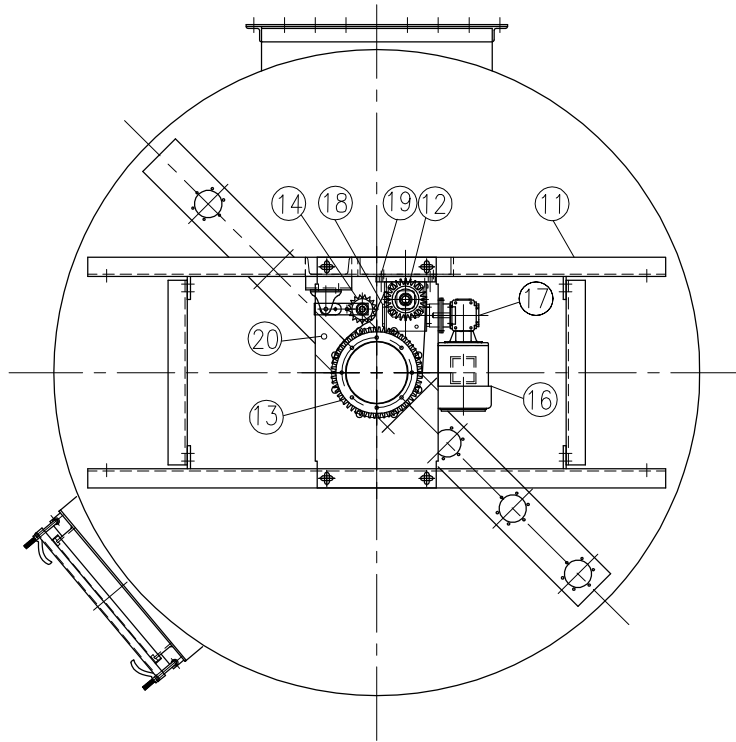

VIEW B-B

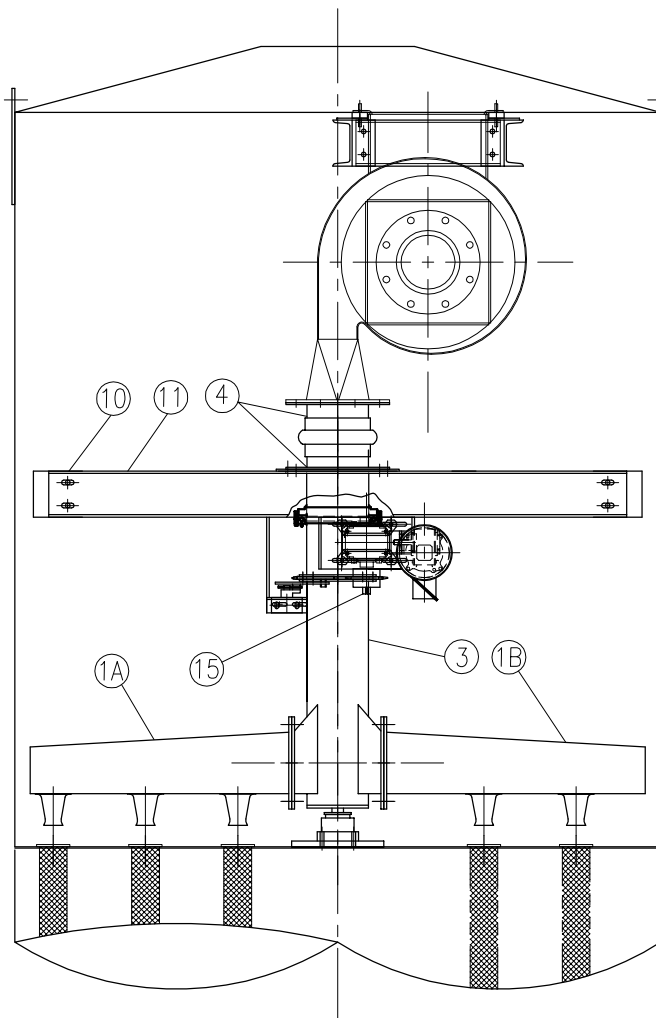

TYPICAL REVERSE AIR SWEEP
ARM DRIVE & FAN ARRANGEMENT
VIEW B-B

RECEIVING YOUR UNIT

Prior to accepting shipment, care must be taken to inspect all equipment received both for proper count and for damage. Any and all irregularities must be noted on the carriers' copy of the shipping receipt to assist in settling any claims for damage or shortages. All equipment is shipped FOB point of origin whether on a prepaid or collect freight basis.

ANY CLAIM FOR DAMAGE IN TRANSIT OR SHORTAGES MUST BE BROUGHT AGAINST THE CARRIER BY THE PURCHASER.

Once your claim has been filed with the carrier contact CAMCORP to notify us of the problem(s), and then we will advise the appropriate repair procedure or recommend it to be returned to the factory depending on the extent of damage.

INSPECTION OF UNIT

Housing: Particular attention should be paid to the sheet metal housing of your collector. The unit should be inspected for dents, cracks, or rips. A dented housing may seriously affect the structural integrity of the unit. If any of these signs are present, note them on the shipping receipt and notify CAMCORP immediately. The entire unit should be checked against the certified drawings for correctness and the manufacturer notified immediately if there are any discrepancies. No corrections may be made without the expressed written consent of the manufacturer.

Components: A count should be made of all pieces received and this should be verified against the carrier's manifest. Boxes should be inspected for rough handling, which may have resulted in hidden damage.

ON SITE STORAGE RECOMMENDATIONS

I. Baghouse and Housing

1. Housing can be stored outside.
2. Equipment must be blacked up to keep the flanges out of the dirt.
3. Many units are supplied with a plain finish bare steel interior. If storage of more than two week is anticipated, the interior should be prime coated before storage.
4. Covering the unit with a tarp is recommended to keep the interior from rusting or corroding as well as keeping the finish in new condition. However, the tarp is not absolutely necessary.

II. Bags & Cages

1. Bags must be stored inside a cool dry area protected from rodents and insects.
2. For extended storage the boxes for the bags should be wrapped with plastic wrap or stretch wrap to protect from moisture.
3. If the bags get wet for any reason, immediately lay them out with adequate ventilation to dry in order to prevent mold and mildew.
4. It is recommended to store the cages inside a dry area if at all possible.
5. If an inside location is not available, cages can be stored outside as long as they are covered by a tarp.
6. Cages are generally stored horizontally on pallets to keep off the ground.
7. If cages can be stored horizontally, do not stack over three boxes high.
8. If the job site is in an area that may receive a significant snow load, the cages must be stored vertically in order to prevent being crushed by the weight of the snow. Do not stack more than one box high.

III. Accessory Parts

1. This includes all gauges, bag clamps, nylon or copper tubing, gaskets, and other ports not specifically called out.
2. These items should be stored inside a cool dry place protected from insects and rodents.

ON SITE STORAGE RECOMMENDATIONS (continued)

IV. Fan and Fan Accessories

1. Fans can be stored outside on a pallet or skid to keep out of water and dirt.
2. Equipment should be covered with a tarp to protect from the bags.
3. Fan silencers, outlet dampers, and inlet boxes should also be tarped and stored on a pallet or skid.

V. Ducting

1. Ducting can be stored outside on a pallet or skid to keep it off the ground. It should be positioned so that water does not sit in the equipment.
2. If ducting is unpainted steel, it should be at least primed coated before storage.
3. If ducting is already finish coated, it should be tarped to protect the finish but is not absolutely necessary.

VI. Knife Gate

1. All limit switches, solenoids, and air cylinder ports must be capped and taped to prevent any moisture or dirt from entering.
2. Equipment can sit outside provided it is covered with a tarp and is on a pallet or skid to keep it out of the water and dirt.

VII. Isolation Dampers

1. All limit switches, solenoids, and air cylinder ports must be capped and taped to prevent any moisture or dirt from entering.
2. Equipment can sit outside provided it is covered with a tarp and is on a pallet or skid to keep it out of the water and dirt.

VIII. Rotary Valve

1. Rotor and interior of valve should be well oiled with vegetable oil to prevent rust and to maintain compatibility with product.
2. Unit can be stored outside provided it is covered with a tarp and is on a pallet or skid to keep it out of the water and dirt.

ON SITE STORAGE RECOMMENDATIONS (continued)

IX. Butterfly (Wafer Valve)

1. All limit switches, solenoids, and air cylinder ports must be capped and taped to prevent any moisture or dirt from entering.
2. Unit can be stored outside provided it is covered with a tarp and is on a pallet or skid to keep it out of the water and dirt and sunlight.

X. Level Indicators

- ❖ Store these items inside a cool dry area protected from rodents

XI. AC Inverters

- ❖ Store these items and all other electrical controls inside a cool dry area protected from rodents.

SETTING UP YOUR UNIT

CAMCORP dust collectors are shipped in various states of assembly depending on the size and configuration of the unit. Before attempting to move the dust collector or any of its sections, review both the certified general assembly drawing supplied with your unit and the rigging and lifting guidelines included in this manual. Become familiar with the size and number of sections to be assembled, the orientation of inlet(s), outlet(s), access door(s), and fan as well as the number and location of lifting lugs.

Dust collectors of this type are manufactured from steel sheets and are quite flexible. Therefore, even though care has been taken to maintain dimensional accuracy and squareness, some difficulty should be anticipated, and temporary bracing in the field may be required.

Rigging and Lifting Guidelines

1. Do not lift the dust collector by any attachments other than the lifting lugs provided.
2. Use all of the lifting lugs provided on the dust collector, or a section of the dust collector, when making a lift.
3. If the lifting lugs are located below the roof line of the dust collector or below the top of the section of the dust collector, a vertical pull must be made to avoid crushing the top of the unit. Use spreader beams to accomplish this vertical pull.
4. Attach tag lines at several locations to be able to control the unit when lifted and to prevent spinning or swinging.
5. The dust collector should be lifted and lowered at a slow, uniform rate and not allowed to bounce or joggle since this can cause excessive impact stresses at the lift points.

Doors and Flanges: Hold-downs on doors should only be hand tightened. Excessive pressure can distort the door panel itself resulting in leakage. All bolts on flanges should be tight. All holes in the dust collector must be plugged prior to start-up if not being connected.

Platform Installation: The platform, ladder, handrail, and bracing are to be installed as shown on the special platform detail provided. Use the part ID's to locate the parts in the proper location.

Explosion Vents (where applicable):

1. Figure 6 – The explosion vents are attached with a minimum of standard steel fasteners for shipment. **THESE MUST BE REMOVED** and the PVC Bolts installed that are included in the shipment. Extreme care should be exercised when installing the PVC Bolts as they are very fragile. A gasket is factory installed that will provide a seal between the vent panel and the frame. **DO NOT** use silicone sealer or any other sealer or adhesive at this joint as this will prevent the vent from operating properly.
2. The area around the vents should be clear of any personnel or obstructions to prevent injury or damage.

Electrical: A 120 volt 60 Hertz circuit is required to operate the dust collector's ½ HP swep arm drive motor. A 230/460V 3 phase circuit is required to run the reverse air fan.

Gauges: Check the pressure differential gauge to make sure that the high-pressure tap is connected below the tube sheet and the low-pressure tap is connected above the tube sheet. Verify that the gauge have been zeroed prior to connection when it is in its permanent mounting position.

Auxiliary Equipment: All auxiliary equipment must be installed according to its manufacturer's specifications and interlocked with the entire system as needed. Direction of rotation of each item must be checked prior to start-up of the entire system.

TOP LOAD BAG AND CAGE INSTALLATION

1. Inspect the cage for any signs of damage, warping, bent wires, or missing welds.
2. Inspect the filter bag for any signs of mold, mildew, ripped seams, or holes.
3. Lower the closed end of the bag through the hole in the tube sheet.
4. With your hands, “kidney shape” the snap band bag top in order to fit and align it within the tube sheet hole.
5. Fit the groove of the snap band to the I.D. of the tube sheet hole and allow it to expand and audibly snap into place. If the band will not snap into place initially, do **not** push on the “dimple” as doing this will permanently damage the snap band. Instead, kidney shape the snap band from the opposite side of the band. Then you can allow the band to expand and audibly snap into place.
6. Check the fit of the snap band to the tube sheet. It should be even in height above the tube sheet around the entire circumference, which will confirm to the installer that the tube sheet is centered and well secured into the middle groove of the snap band.
7. Lower the cage into the bag and press that cage top down into the bag’s snap band I.D. When in position, the rolled flange of the cage top will rest on the tube sheet and the bag and cage assembly will be rigidly mated. The O.D. of the cage top provides a compression fit to the I.D. of the snap band.
8. Disconnect the drive chain to allow the sweep arm to rotate freely to access the holes under the sweep arm if necessary.
9. Replace access doors and tighten accordingly. You are ready to begin start-up procedures if all other preceding tasks and hook-ups are completed.

BEADED SNAPBAND FILTER BAG DESIGN FOR FLAT TUBESHEET HOLE

The snapband was developed to improve sealing efficiency. This design eliminates multiple parts, minimizing labor expenses. Camcorp provides a uniform double beaded gasket in the cuff assembly. This assures a leakproof seal for flat plate tubesheet holes. When installing the bags, follow instructions provided.

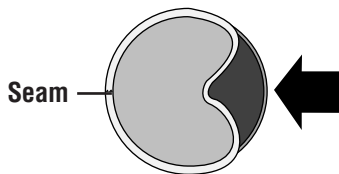

Top View

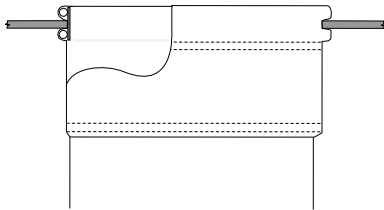

Flat Plate Tubesheet Hole

PROPER INSTALLATION OF THE CUFF

1. Form the snapband into the shape of a kidney. The vertical seam in the cuff should be on the outer radius of the kidney shape.
2. Seat the seam of the cuff into the hole first with the tubesheet fitting between the beads, with one above and one below it .
3. Release the band and it will spring securely into place. Use caution, and ensure all fingers are out of the tubesheet opening when the snapband is released. Make sure the snapband fits squarely in the hole and there are no kinks in the metal band.

NOTE: If you are converting to a snapband bag from some other type of sealing method, the tubesheet holes must be inspected carefully to ensure that proper sealing will result. The surface finish on the inside diameter must be relatively smooth. Any deep grooves or protrusions will cause leakage. A hole that was flame cut, but not ground smooth is one example. The tubesheet holes must be consistent in circumference from one hole to another.

If the circumference difference is determined by measuring, the holes should be checked to the nearest 0.001 in. Slight out-of-roundness is acceptable. Take three measurements for each hole and record the average of these three measurements. Compare all the hole averages. The difference between the largest average and smallest average hole size should not exceed 0.020 in. Try sample cuff in largest and smallest hole to confirm proper fit.

When checking the sample snapband in the hole for fit, push on the edge of the snapband slightly with your thumb to try and move it inward. If a gap occurs easily between the snapband and the edge of the tubesheet hole, leakage may result. If the inside surface of the hole is smooth, check the cuff fit by trying to spin the cuff in the hole. If it spins easily, it may leak.

START-UP CHECKLIST

1. Installation

Make sure the unit is secured to grade. The ladder(s) and platform(s) must be tightened and set up according to OSHA requirements. Ducting and piping must be secured and routed out of the way of traffic whenever possible to avoid injury. Ducting must also be free of all debris including moisture.

2. Interior of the dirty air plenum

A. Make sure that the filter bag assemblies hang straight and the bottoms do **not** touch each other or any part of the collector interior. If this occurs, the bags will have holes worn in them wherever they contact and will require replacement.

B. High-level alarms should be connected sufficiently below the air inlet(s) to avoid a plugged up inlet or blinded off filter bags.

3. Clean air plenum

A. All bolts on the flanges must be in place and properly tighten.

B. Verify that the reverse air fan and sweep arm drive are properly installed.

4. Exterior of dust collector

A. Access doors, inspection ports, and relief vents should seat effectively to prevent leakage.

B. All bolts must be properly tightened.

C. Operate any equipment connected to the dust discharge of the dust collector. Check the rotation of any motor driven equipment such as rotary airlocks, horizontal unloading valves, live bottom bin activators, and screw conveyors. Check slide gates and butterfly valves for binding.

5. Explosion relief panels – shear bolt style (where applicable)

A. Inspect for broken or missing bolts.

START-UP DUST CONTROL SYSTEMS

1. Fan or blower system
 - A. Start the fan or blower and check rotation.
 - B. Check dust pickup points for proper suction; balance airflow in individual ducts.
 - C. Check for air leakage at all flanged connections.
2. Equipment start-up sequence
 - A. Start the sweep arm drive motor (direction of rotation is not critical).
 - B. Start the reverse air fan motor and check rotation.
 - C. Dust take away equipment such as rotary airlocks, screw conveyors, horizontal unloading valves, live bottom bin activators, and pneumatic conveying systems can now be started in their correct sequence.
 - D. Check that all access doors, hatches, ports, and other openings are closed and latched or bolted.
 - E. The main exhaust fan can now be started and brought up to speed.
 - F. Start the dust laden air through the collector. The collector should be started under partial load to allow the bags to become slowly and evenly coated with dust particles.

On pneumatic conveying systems, watch the differential pressure gauge closely for the first hour or so. If unstable, the collector discharge system may be too small for the volume it is seeing. A quick fix is to reduce the material feed until the discharge rate can be increased.

- G. Observe the manometer or magnahelic differential pressure gauge reading. As the new filter bags become coated with dust, the efficiency of the filtering action increases, and the differential pressure across the filter bags will also increase. Slowly bring the collector to full load and note the final pressure drop across the filter bags. Never allow the pressure drop across the filter bags to exceed 17" w.g. maximum or filter bags may collapse.
- H. Check the main airflow with a pitot tube, or equivalent measuring device, to establish initial conditions. If the main airflow must be adjusted up or down to suit the process, repeat step 2-H above.

SHUT-DOWN PROCEDURES

1. Dust control systems

Reverse start-up procedure, shut down fan, then after 5 or 10 minute delay, shut down the reverse air fan and sweep arm drive motor.

2. Pneumatic systems

Reverse start-up procedure, shut down fan, then after 5 or 10 minute delay, shut down the reverse air fan and sweep arm drive motor.

TROUBLESHOOTING THE DUST COLLECTOR

I. Excessive pressure drop across filter bags

The differential pressure gauge or manometer on your dust collector should read 6" w.g. or less. Higher readings and/or steadily increasing readings are an indication that the main airflow through the dust collector may be restricted, and a potential process problem such as poor suction at duct pickup points may exist. In extreme cases (over 17" w.g.) filter bags will be damaged. Check the following:

A. Pressure Gauge

Check the differential pressure gauge or manometer and the tubing leading to the dust collector for proper operation. Disconnect the lines at the gauge or manometer and clear with compressed air. Look for loose fittings, cracked, broken, or pinched tubing. Make sure the gauge is zeroed or that the manometer is level, zeroed and contains the correct fluid.

B. Bags Loaded with Dust

If the cleaning system is not operating properly refer to the section titled "Troubleshooting the Cleaning System".

A condition known as blinding. If the dust is dry, see paragraph 1-4; if the dust is wet, see paragraphs 5 and 6.

1. Dust Not Discharging from the Hopper

Check hopper for over-loading or bridging across the dust discharge. Correct by repairing dust discharge equipment, replacing with higher capacity equipment, or installing hopper vibrators, etc. as required to keep the hopper clear.

2. Air Flow too High

If the main airflow is too high to allow dust to drop off of the filter bags, an excessive pressure drop across the dust collector will result and dust will build up in the system. In many cases this high pressure drop in turn leads to a reduction in the main air flow so that it is necessary to remove the dust accumulation from the filter bags (and the rest of the system) before measuring the main air flow volume.

TROUBLESHOOTING THE DUST COLLECTOR (continued)

Visually inspect the bags for heavy caking; if caking is evident, see the note below and take the necessary action to clean the bags. Next, measure the main airflow with a pitot tube or equivalent device and compare with the original volume for which the unit was designed. If the flow is too high, cut back the main fan to prevent a recurrence of the problem.

3. Particle Size and Dust Load

If possible, compare the dust particle size and loading with the original design specifications. Finer dust may cause a higher pressure drop. Do not hesitate to call the factory; we have experience with many kinds of dust.

4. Bags Too Tight

Bags that have shrunk on their cages may not flex sufficiently during the compressed air pulse to loosen caked dust. If the bags were cleaned or laundered, pull a bag tight around its cage; you should be able to “gather” a small fold of material between your fingers.

5. Water Leaks

Inspect the dust collector housing and ductwork for holes, cracks, or loose gasketing where water could enter the collector.

6. Condensation

If moisture has been condensing inside the collector, check the dew point temperature of the incoming air stream. It may be necessary to insulate the collector and/or the ductwork leading to the collector to keep surface temperatures above the dew point and prevent condensation of the filter bags.

NOTE: Collectors that have had blinded or caked bags can possibly be put into service by running the pulsing air system for 15 to 30 minutes with a 10 second timer “off time” and without the main fan or blower. If the pressure drop is not lower when the main fan is started again, take the bags out of the collector and remove the caked dust by special dry-cleaning. Make sure the timer “off time” has been reset to specifications prior to re-start. Information pertaining to filter bag cleaning may be obtained by calling your CAMCORP sales representative.

TROUBLESHOOTING THE DUST COLLECTOR (continued)

II. Extremely Low Pressure Drop

A. Pressure Gauge

Check the differential pressure gauge or manometer and the tubing leading to the dust collector as in I-A of this section.

B. Holes in Filter Bags or Bags Incorrectly Installed.

Inspect the filter bags for holes, rips, tears, or excessive wear. Make sure that the filter bags were installed correctly according to the “Bag & Cage Installation” section.

C. Ductwork and Dampers

Inspect the ductwork to and from the dust collector for air leaks or blockage. Make sure that any dampers in the system are correctly positioned to allow air to flow through the dust collector.

D. Leaks in the Housing

Check the tube sheets (flat steel sheets from which the filter bags are suspended) and the dust collector housing for holes, cracks or loose gasketing that would permit air to bypass the dust collector or filter bags.

III. Continuous Flow of Dust in the Clean Air Exhaust (Primary Dusting)

A. Holes in the Filter Bags or Bags Incorrectly Installed

Inspect the filter bags as in II-B this section.

B. Holes in the Tube Sheets

Check the tube sheets for holes, cracks, or loose bolts that would permit dusty air to bypass the filter bags.

IV. Puff of dust in the clean air exhaust after each pulse (secondary dusting)

A. Worn filter bags

Inspect the filter bags for wear. Thin bags may not stop fine dust when flexed by a compressed air pulse.

TROUBLESHOOTING THE DUST COLLECTOR (continued)

B. Residual Dust

If dust has gotten into the clean air plenum because of a dropped or torn bag, hole in tube sheet, etc., the reverse air may stir up the dust and allow it to escape into the clean air exhaust. Residual dust may also be driven down inside the filter bags by the reverse air; if the filter bags are filled with several inches of dust, clean both the clean air plenum and the filter bags to avoid further problems.

V. Short Filter Bag Life

This is often a complicated problem to diagnose and we recommend calling the factory for advice. The following list may be helpful in performing some preliminary check:

A. Temperature

Operating Temperature above the recommended limit of the filter bag material (220 degrees F max.)

B. Chemical Attack

Bag material degrades due to attack from certain chemicals in the dust or gasses in the air stream.

C. High Moisture

High moisture content in the collector may cause certain filter bag material to shrink or degrade (more rapidly at elevated temperatures).

D. Localized abrasion

Abrasion of the bags at the dusty air inlet; a dust impingement baffle may be required.

E. Internal Bag Supports Gone Bad

Corroded, rusted or broken filter cages can cause excessive bag wear. Stainless steel or coated cages are available.

TROUBLESHOOTING THE CLEANING MECHANISM

1. Fan - If the fan is not operating properly please refer to the New York Blower manual located in this IOM manual.
2. Sweep Arm Drive – Motor not rotating.
 - A. Remove the motor from the gear drive and check for proper operation. If the motor does not rotate, repair or replace.
 - B. If the motor does rotate properly check for binding or roughness in the gear drive. Repair or replace one or both gear boxes as necessary.
3. Sweep Arm Drive – Motor rotating and sweep arm not rotating or rotating intermittently.
 - A. Enter the clean air plenum and check for obstructions in the path of the rotating sweep arm. Remove any obstructions
 - B. Verify that the sweep arm is rotating parallel to the tubesheet and that the nozzles do not strike the cage tops and cause the sweep arm to stop. If this is not the case call the factory.
 - C. Verify that the torque limiting clutch on the small sprocket is slipping.
 - D. Verify that the chain is not binding. If it is then check the sprocket alignment.
 - E. Disconnect the drive chain. The sweep arm should rotate freely and with no binding or roughness. If binding is experienced grease the rotary union. If the binding or roughness continues inspect the bearing and replace if necessary.

SAFETY RECOMMENDATIONS

Because this unit may be under pressure, do not attempt to open any device doors or panels while fans or blowers are running.

If your unit is equipped with a discharge auger or an airlock, be sure chain guards are installed before start-up and servicing is attempted only after electrical power is locked out.

While servicing the filter, it is very important that there are no open flames, welding or grinding sparks. Dust laden air could be highly explosive and extreme care must be taken.

Before entering any dust collector:

1. Run cleaning mechanism 20 minutes with the fan off to clean filter bags.
2. Discharge solids from hopper.
3. Lock out electrical power on all rotating equipment.
4. On toxic operation, purge collector housing and install a blank in the inlet duct.
5. Install catwalks and safety cables.
6. Secure access doors in an open position or remove doors.
7. Use buddy system.
8. Wear a respirator.
9. Use common sense.

ROUTINE MAINTENANCE

A. Inspection

Frequency will vary as widely as there are operating conditions. In general proceed as follows:

1. Daily – Check unit differential pressure.
2. Weekly – Verify that the sweep arm drive and reverse air fan are operating properly.
3. Monthly – Lubricate fan, rotary valve and screw conveyor. Check seals on latter two for dust loss.
4. Quarterly – On Top Access Units, check for dust accumulation in clean air plenum.

B. Repairs

1. Filter bags – Generally replacement, although some applications can be laundered.
2. Rotary Valves – Usually a matter of periodic seal and blade replacement. More detailed information is supplied with the valve.
3. Screw Conveyors – Periodic replacement of “V” belts and shaft seals. Inspect hanger bearings during filter bag change. Failure will be detected by the squeal.
4. Fans – “V” belt tension and replacement of bearings if running rough. Make sure rotor balance is maintained.

COMPONENT IOM MANUALS

MORSE RAIDER WORM GEAR SPEED REDUCER (Maintenance).....	1-8
MARTIN TORQUE LIMITER CLUTCH	7-10
NEW YORK BLOWER PRESSURE BLOWER (IOM)	11-16



Emerson Power Transmission
P O Box 687
MAYSVILLE, KY 41056
Phone: 800-626-2093
www.emerson-ept.com

FORM
8721
March 2003

**MAINTENANCE INSTRUCTIONS
FOR WORM GEAR
SPEED REDUCERS**

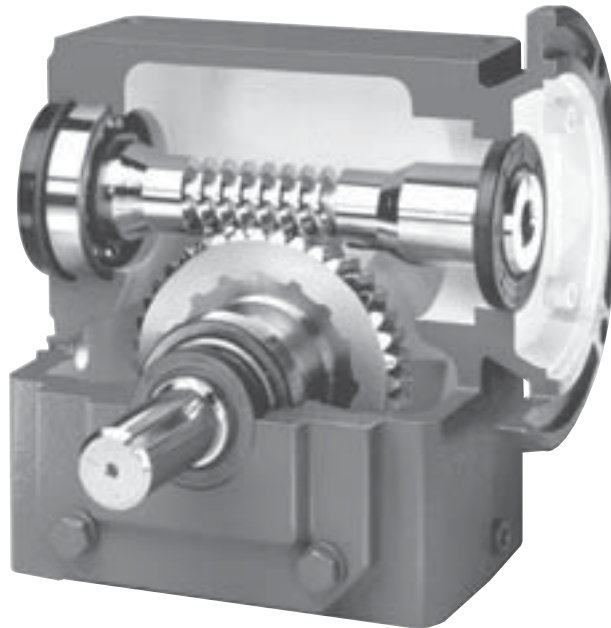

Center Distances

**1.33, 1.54, 1.75, 2.06, 2.37, 2.62, 3.00, 3.25
3.75, 4.50, 5.16 and 6.00**

EMERSON
POWER
TRANSMISSION™



EMERSON™
Industrial Automation

INTRODUCTION

The following instructions apply to RAIDER® Worm Gear Speed Reducers. When ordering parts or requesting information be sure to provide all the data stamped on the reducer nameplate.

EQUIPMENT REQUIRED

In addition to standard Mechanic's tools, the following equipment is required: arbor press, wheel puller, torque wrench, dial indicator, seal driver, bluing, adhesive sealant, snap ring pliers for internal and external rings.

GENERAL INSTRUCTIONS

Housings - Clean external surfaces of reducer before removing seal cages and end covers to prevent dirt from falling into the unit. Record mounting dimensions of accessories for reference when reassembling. If it is necessary to remove the reducer from its operating area, disconnect all connected equipment and lift reducer from its foundation.

Seals - Replacement of all seals is recommended when a unit is disassembled. However, if seals are not to be replaced, protect seal lips by wrapping shaft with plastic tape coated with oil or grease before removing or replacing seal cage assembly. Clean the shaft but do not use any abrasive material on the shaft surface polished by the seal.

▲CAUTION If the reducer is painted, extreme care should be taken to mask the shaft extensions and rubber surface of the seals. Paint on the shaft adjacent to the seal or on the seal lip will cause oil leakage.

CAPSCREW TIGHTENING TORQUES

Capscrew Size	Torque (Ft. Lbs)
1/4 - 20	6.25
5/16 - 18	13
3/8 - 16	20
7/16 - 14	35
1/2 - 13	50
5/8 - 11	90

Table 1

TO CHANGE OUTPUT SHAFT DIRECTION

To change the hand of a unit from left hand to right hand, or vice versa, the following instructions apply:

1. Remove drain plug and drain oil from unit.
2. Remove end cover and seal cage capscrews; then while supporting output shaft remove end cover and shims from the unit. (The shims may be between the seal cage/end cover and housing, or between the bearing outer race and seal cage/end cover - do not remove the bearing race unless it is to be replaced).



3. Remove output shaft and seal cage together from extension side.

NOTE: Keep all shims with their respective seal cage and end cover.

4. Reassemble unit per instructions later in this manual.

UNIT DISASSEMBLY

1. Remove **drain plug** and drain oil from unit.
2. **Low speed shaft** (gear shaft) removal:
 - A. Remove end cover and seal cage capscrews.
 - B. With a firm hold on the output extension remove end cover and shims (The shims may be between the seal cage/end cover and housing, or between the bearing outer race and seal cage/end cover - do not remove the bearing race unless it is to be replaced).
 - C. Carefully slide output shaft assembly and seal cage out extension side.
 - D. Slide seal cage off low speed shaft using caution to prevent damage to seal lips.
 - E. Wire or tie the shims to their mating end cover and seal cages. (This only applied if the shims are between the seal cage/end cover and housing). They will be available for reference when assembling the unit. Some units are factory assembled with internal shims so this note may not apply.

	<p>▲WARNING</p> <p>High voltage and rotating parts may cause serious or fatal injury.</p> <p>Turn off power to install or service.</p> <p>Operate with guards in place.</p> <p>Read and follow all instructions in this manual.</p>	
---	--	---

▲WARNING Disconnect all before adjusting units

3. High speed shaft (worm shaft) removal:

C-Flange units *1.33 C.D. through 3.25 C.D.:*

Use a small chisel to make a groove in the stamped steel cover opposite the motor flange. Pry off the cover. Remove internal snap ring from housing bore. Remove motor flange. Using a plastic hammer, gently tap on the motor end of the shaft to feed worm shaft assembly through housing and out.

3.75 C.D. through 6.00 C.D.:

Remove motor flange. Remove seal cage opposite motor face. Keep shims with seal cage for reassembly. Remove bearing nut and washers from end opposite motor. Using a plastic hammer, gently tap the shaft on the motor end. Push shaft assembly through housing until rear bearing outer race is free. Slide bearing inner-races off the shaft and remove worm through front of housing. If a press is available, pressing the shaft out is preferable.

Basic units *1.33 C.D. through 3.25 C.D.:*

Use a small chisel to make a groove in the stamped steel cover opposite the motor flange. Pry off the cover. Remove internal snap ring from housing bore. Remove motor flange. Using a plastic hammer, gently tap on the extension end of the shaft, to feed worm shaft assembly through housing and out. On units with C.D. of 1.33, 1.54, 2.63, and 3.00, front bearing will remain in housing bore. Use soft tool and plastic hammer to tap bearing out extension end of housing from rear. Be sure to tap on outer-race of bearing. If a press is available, pressing this bearing out is preferable.

3.75 C.D. through 6.00 C.D.:

Remove front and rear seal cages. Keep shims with seal cages for reassembly. Remove bearing nut and washers from end opposite extension. Using a plastic hammer, gently tap the shaft on extension end. Push shaft assembly through housing until rear bearing outer-race is free. Slide bearing inner-races off shaft. Reverse direction and push shaft through extension end of housing and out. If a press is available, pressing the shaft out is preferable.

PARTS SERVICE

1. **Housing** – Clean inside of housing with kerosene or solvent and then dry.
2. **Seal cages and end cover** – Remove dirt from joint faces, wipe clean and dry.
3. **Air vent** – Wash in kerosene, blow clean and dry.
4. **Seals** – To replace seals without dismantling reducer refer to steps C through F below. To replace seals when the entire reducer is dismantled and coupling hubs, sprockets, pulleys, pinions, keys, etc. have been removed the following instructions apply:

Note: Replacement of all seals is recommended when a unit is disassembled. New seals will leak if the seal lips are damaged or if seal's rubbing surface on the shaft has been altered. Protect seal lips at all times. Clean the shaft but do not use any abrasive material on the shaft surface polished by the seal.

- A. Block up seal cages and press or drive out seal.
- B. Remove old sealing compound from seal seat in cage if it is present. If a seal with rubber coating on the outside diameter is used, no sealant is necessary. If no rubber coating is on seal outside diameter, coat seal cage bore with adhesive sealant immediately before assembly.
To prevent possible damage to seal lips, do not reassemble seals until high speed and low speed shafts have been reassembled to the housing. Then see steps E and F below.
- C. See Figures 1 through 4 – To replace seals without dismantling reducer, proceed as follows:
Do not damage shaft; new seals will leak if seal contacting surface is marred. Use punch and place two or more holes in steel casing of seal, Figure 1. (The steel casing may be rubber coated) Insert sheet metal screws, leaving the heads sufficiently exposed so they can be pried up or grasped with pliers, Figure 2. Do not drill holes because chips may get into the unit.

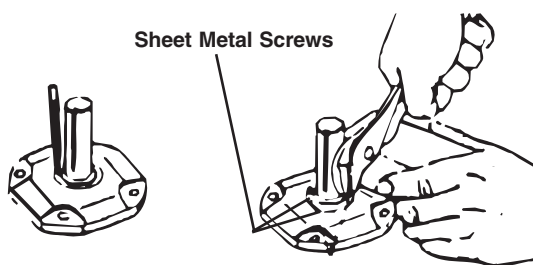

Figure 1

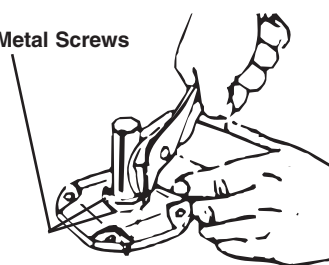

Figure 2

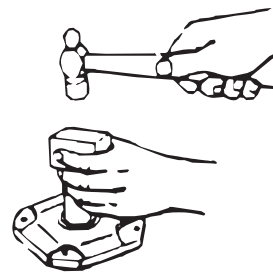

Figure 3

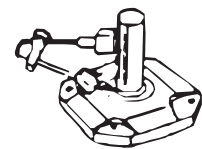

Figure 4

▲ WARNING Disconnect all power before adjusting units

- D. Work seal loose. Be careful to keep all metal or dirt particles from entering unit. Remove old sealing compound from seal seat if it is present. Also remove burrs and sharp edges from shaft. Clean with rag moistened with solvent. Do not use abrasive material on shaft seal contacting surface.
- E. Protect seal lips when handling; seal leakage will result if these are damaged. If a seal with rubber coating on the outside diameter (O.D.) is used, no sealant is necessary. If no rubber coating is on seal O.D., coat seal cage bore with adhesive sealant. Coat seal lips with oil and carefully work seal into position. Before sliding seal into position, protect seal lips from shaft keyway edges by wrapping shaft with plastic tape coated with oil. Position garter spring toward the inside of the unit. Place a square faced pipe or tube against the seal O.D. and drive or press seal until fully seated as shown in Figure 3. Do not strike seal directly.
- F. For best performance, seat the seal square with shaft within .005" at 180°. Check with dial indicator as shown in Figure 4, Page 3, or with a straight edge and feelers, or square and feelers. To straighten a cocked seal, place tubing over the seal and tap the tube lightly at a point diametrically opposite the low point on the seal. Do Not strike seal directly.

5. **Bearings –**

- A. Wash all bearings per bearing manufacturers recommendations and then dry.
- B. Inspect bearings carefully and replace those that are worn or questionable.
Note: Replacement of all bearings is recommended.
- C. Use a wheel puller or press to remove worm shaft bearings. Apply force to inner race only – not to cage or outer race.
- D. Use a wheel puller or press to remove taper bearing inner races.
- E. To replace tapered bearing inner races and all ball bearings, heat bearings in an oil bath or oven to maximum of 290° F (143° C). Slide high speed shaft bearings onto the oiled shaft until seated against the shoulder or snap ring of the shaft. Slide low speed shaft bearing onto the oiled shaft against the gear spacer.
- F. Thoroughly coat all bearings with lubrication oil.

6. **Worm, gear and shafts**

- A. Worm and high speed shaft – since all worms are integral with the high speed shaft, any wear or damage to the worm will necessitate replacing both.
- B. Press shaft out of bronze worm gear. To reassemble gear and low speed shaft, freeze shaft or heat gear. Do not exceed 200° F (93° C). Insert key into the shaft keyway and press shaft into oiled gear bore.
Note: It is advisable to replace both the worm and worm gear should either of the assemblies require replacement.

UNIT REASSEMBLY

1. **Preliminary**

- A. Check to see that all worn parts have been replaced, gear and bearings coated with oil and all parts cleaned. Remove all foreign matter from unit feet. The feet must be flat and square with each other.
- B. Before starting to reassemble reducer, clean old shims or replace with new shims of equal thickness.

2. **High Speed Shaft (Worm Shaft) Assembly**

C-Flange units *1.33 C.D. through 3.25 C.D.:*

Lubricate Bearing Bores of Housing. Press bearing onto end of worm shaft flush to shoulder (or snap ring). Lock bearing onto shaft with external snap ring. Insert shaft assembly from opposite motor end into housing until seated against shoulder in bore. Lock shaft assembly into housing bore with internal snap ring. Coat outside diameter of stamped steel end cover with adhesive sealant (except, if end cover is rubber coated DO NOT use sealant) and press into input bore opposite motor flange until flush with housing.

C-Flange units *3.75 C.D. through 6.00 C.D.:*

Apply adhesive sealant to both housing input faces. Sub-assemble the two bearing inner-races onto rear of worm shaft and secure with lock nut and washers. Insert shaft assembly into rear bore of housing along with the first bearing outer-race. With plastic hammer gently tap end of shaft until bearing outer-race is seated against shoulder in housing bore. If a press is available, pressing the assemble in is preferable. Press the final bearing outer race in and install the rear seal cage. Adjust end play per instructions below (Item 3C). Install motor flange.

Basic units *1.75 , 2.06, 2.37 and 3.25 C.D.:*



Lubricate Bearing Bores of Housing. Sub-assemble the rear bearing onto worm shaft. Lock rear bearing onto shaft with external snap ring. Insert shaft assembly from opposite extension end into housing until bearing is seated against shoulder in bore. Lock shaft assembly in housing bore with internal snap ring. Coat outside diameter of stamped steel endcover with adhesive sealant (except, if end cover is rubber coated DO NOT use sealant) and press into input bore opposite extension, until flush with housing.

1.33 , 1.54, 2.62 and 3.00 C.D.:

Lubricate Bearing Bores of Housing. Sub-assemble the rear bearing onto worm shaft. Lock rear bearing onto shaft with external snap ring. Insert shaft assembly from opposite extension end into housing until bearing is seated against shoulder in bore. Lock shaft assembly in housing bore with internal snap ring. Press front bearing into extension side of housing until seated against shoulder or snap ring on the worm shaft. Coat outside diameter of stamped steel endcover with adhesive sealant (except, if end cover is rubber coated DO NOT use sealant) and press into input bore opposite extension, until flush with housing.

3.75 through 6.00 C.D.:

Apply adhesive sealant to both housing input faces. Press extension side bearing inner-race onto worm shaft. Insert worm shaft into extension side bore of housing. Hold worm shaft in place and slip bearing inner-race onto shaft until seated against shoulder. Press rear bearing outer-race into housing bore opposite extension until seal cage can be installed. Install seal cage. Adjust end play per instructions below (Item 3C).

3. Low Speed Shaft (Gear Shaft) Assembly

- A. Determine output shaft direction.
- B. Assemble low speed shaft assembly, seal cage, and end cover with shims on both seal cage and end cover. Torque capscrews to torques listed in Table 1. Rotate the input shaft to seat output bearings.
- C. Moving the shaft back and forth by hand, check axial float with dial indicator as shown in Figure 5. Axial float must be .0005 - .003" with .0005 being the absolute minimum. Do not preload bearings. If the axial float is not as specified, add or subtract required shims under end cover or behind bearing outer race, inside the cover, depending on the unit.
- D. Remove output shaft with seal cage and apply bluing to several teeth on the gear. Worm thread and gear teeth must be clean of oil. Reassemble output shaft and seal cage with output key facing up.
- E. Use a rag to apply hand pressure to the output shaft and rotate the high speed shaft both directions until the gear teeth with bluing have gone through gear mesh several times. Return output shaft to original position. Remove output shaft and seal cage to inspect contact. Compare with Figure 6. If contact is not correct, move assembly in the direction shown in Figure 6 by adjusting the shims. Maintain the same total shim thickness so the bearing end play is not affected. Repeat Steps D a E until contact pattern is acceptable.
- F. Recheck axial float with dial indicator.
- G. When contact pattern is correct, tighten seal cage and end cover capscrews to torques listed in Table 1.

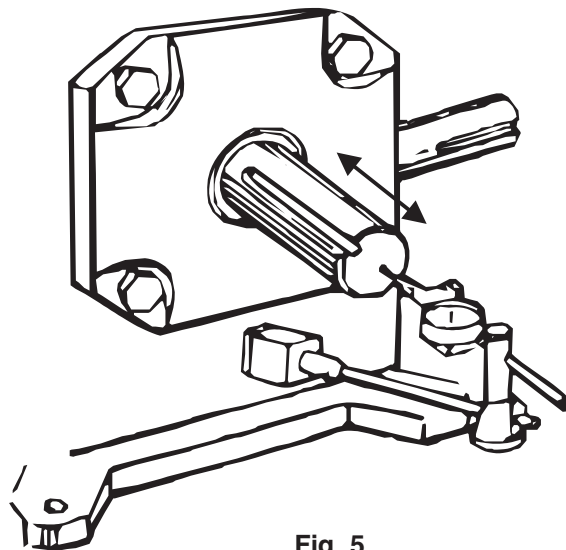

Fig. 5

▲WARNING Disconnect all power before adjusting units

4. **Seals** - To reassemble seals to unit, see Parts Service Steps on Page 3.
5. **Motorized Coupling Adapter**
Reassemble using the original dimensions determined under "General Instructions" on Page 2.
6. **Final Inspection**
 - A. Turn the gear train by hand as a final check.
 - B. Re-install reducer and accessories.
 - C. Fill reducer with the recommended oil to the appropriate level. See the installation instructions supplied with the reducer.
 - D. Spin test for three minutes and check for noise, leakage or rapid temperature rise.



Fig. 6b: ACCEPTABLE

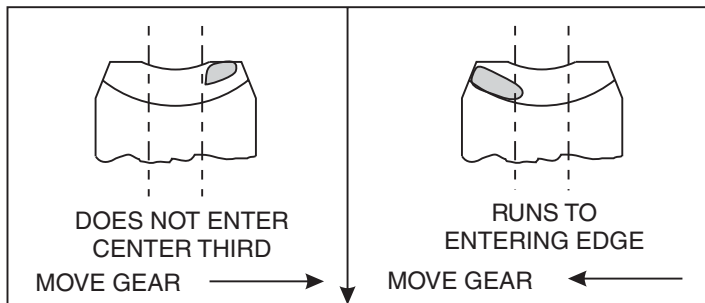

Fig. 6c: UNACCEPTABLE

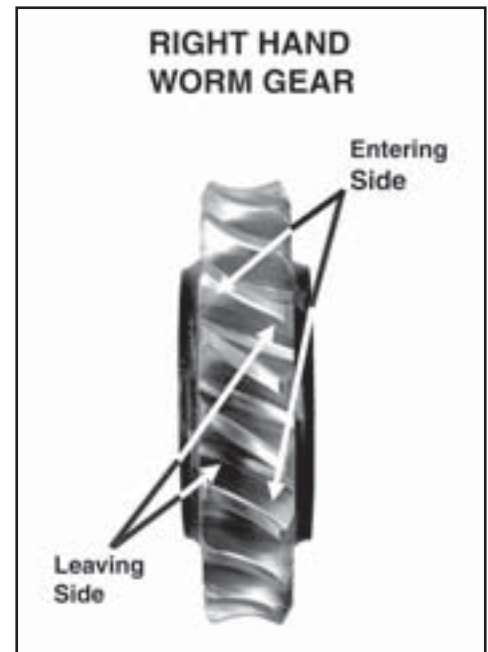

Fig. 6a: Entering and Leaving Sides

PREVENTATIVE MAINTENANCE

1. After first week, check all external capscrews and plugs for tightness.
2. Periodically, check oil level when gears are at rest. Add oil if needed. Do not fill above the recommended level because leakage and overheating may result.

Emerson Power Transmission
P.O. Box 687
Maysville, Kentucky 41056
TEL: 800-626-2093



Martin

SPROCKET & GEAR, INC.

TORQUE LIMITER CLUTCH DRIVE OVERLOAD PROTECTION



Now in Stock at All **Martin** Facilities
Also Stock Plate Sprockets Bored to
Size and Face Ground for Torque Limiters

Martin TORQUE-LIMITER clutch offers thrifty overload protection that's easy to adjust.

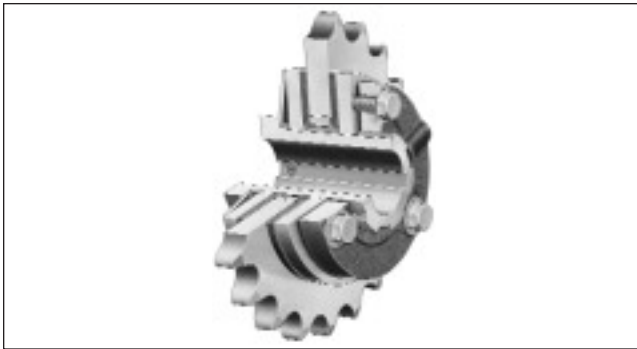

Here is low cost protection for your machinery . . . a torque limiting clutch that is easy to install.

Torque-Limiter clutches feature an exclusive "Easy-Set Adjustment." With "Easy-Set," torque adjustment is accomplished quickly! The need for hammer and block, brute strength and spanner wrenches is eliminated.

These simple steps and the job is done:

1. Snug up the adjusting nut, finger tight, locate set screw over nearest spline notch and tighten. See table at right.
2. Tighten three cap screws until heads bottom — with a small wrench; this gives maximum torque.
3. For less torque — back off the cap screws, loosen the set screw, back off adjusting nut to one of the six spline notches as required, and retighten set screw and cap screws.

"Easy-Set Adjustment" not only simplifies installation, it provides solid support for pressure plates by compression at their peripheries.

The Torque-Limiter clutch gives machinery permanent protection against overloads during starting, reversing or driving — by slipping at any desired load. It resumes driving without resetting when the overload is relieved. It is simple in design, compact, efficient and built for long life. It provides low cost torque limiting service for a wide variety of applications. No lubrication . . . minimum maintenance.

Starting shock from electric motors is a major cause of maintenance of moving parts. Torque-Limiter clutches provide a cushion by slipping until the torque drops to a pre-set level. They can be set to reduce shock loads on motors and driven equipment during reversing or inching. They provide mechanical protection against breakage due to sudden overload — by slipping when the pre-set torque limit is reached.

Torque-Limiter clutches may be used with a sprocket, gear, sheave, flange or other driven member. It is recommended that the rubbing sides of the driven member be ground to provide a smooth rubbing surface of 65 to 125 micro-inches. See torque rating table on following page.

The driven member is mounted on an oil-impregnated bushing and clamped between two, high quality friction discs by spring pressure. Each Torque-Limiter unit, completely assembled, contains one spring. Higher torque ratings can be obtained by the use of a second spring nested within the original spring. See rating table on following page.

When an overload occurs, the driven member slips between long-life, clutch-type friction discs. After slipping has started, it will continue at approximately 90% of the torque setting, due to the lower coefficient of friction when slipping, until the overload condition has been corrected.

TORQUE-LIMITER CLUTCH CALIBRATION

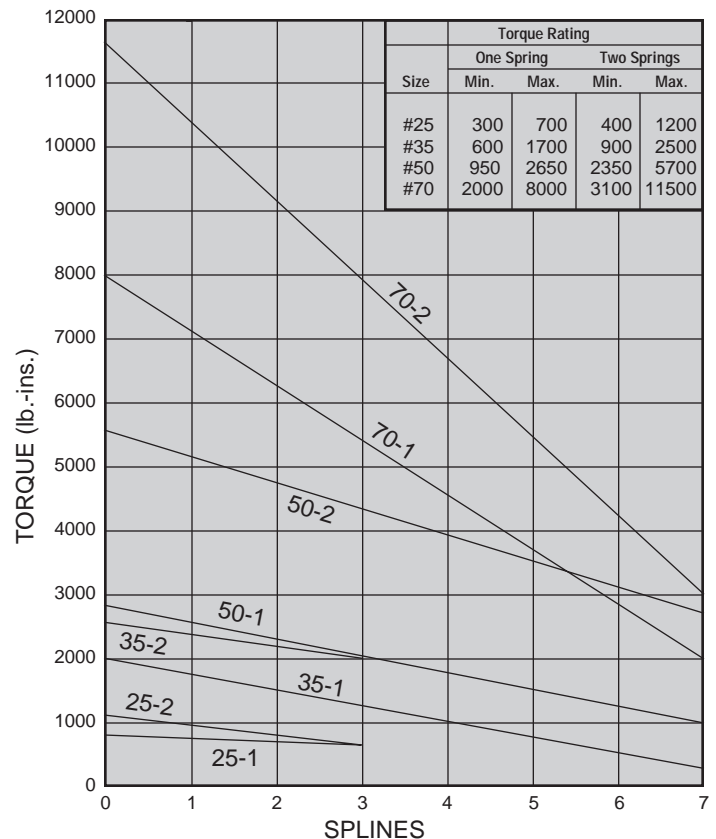

Note:

Graph indicates approximate rated torque vs number of splines adjusting nut is backed off from finger tight.

Torque-Limiter Clutches



TORQUE-LIMITER CLUTCHES

Each assembled unit contains one spring. Higher ratings can be obtained by ordering a second spring to nest in the original one. Bushings need to be ordered separately if required.

The rubbing sides of the center member should be ground parallel — 65 to 125 micro-inches.

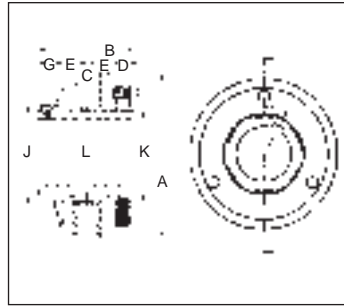

Stock Plate Sprockets with Ground Face and Bored to Fit the **Martin** Torque Limiter

UNIT TT25

Sprocket Size
35TTA25-25
35TTA26-25
40TTA20-25
40TTA22-25
40TTA24-25
40TTA28-25
40TTA30-25
50TTA17-25
50TTA21-25
50TTA22-25

UNIT TT35

Sprocket Size
35TTA35-35
35TTA40-35
40TTA28-35
40TTA30-35
40TTA32-35
50TTA22-35
50TTA24-35
50TTA25-35
50TTA26-35
60TTA18-35
60TTA20-35

Torque-Limiter Clutch Ratings

Size No.	Avg. Wt.	Torque Rating ▲ (Pound-Inches)				C										K +.000 -.002 Spline O. D.	L +.003 -.000 Spkt. Bore
		With One Spring		With Two Springs**		A	B	Min.		D	E	G	H	J			
		Min.	Max.	Min.	Max.			Min.	Max.								
TT25	1	300	700	400	1200	2½	1¾	¾	1½	2/16	3/16	3/16	2/16	1½	1.368	1.631/1.628	
TT35	2.5	600	1700	900	2500	3½	2½	¾	¾	5/16	3/8	3/8	3/8	1 1/16	1.675	2.006/2.003	
TT50	6	950	2650	2350	5700	5	2½	¾	¾	5/8	7/16	7/16	4/8	2 1/8	2.625	3.008/3.005	
TT70	18	2100	8000	3100	11500	7	3½	¾	1½	5/8	3/4	3/4	2/2	4	3.811	4.197/4.194	

▲ Using a center member with rubbing sides ground parallel — 65 to 125 micro-inches. Center member must be clean and free from oil, rust, etc.

** Second spring may be nested in one originally furnished. Order if required.

◆ Nominal for maximum torque setting. For minimum torque setting, add 3/64 for No. 25; 5/64 for No. 35; 3/32 for Nos. 50 and 70. When two springs are used this dimension is increased approximately 1/16" on Nos. 25, 35 and 50 — 3/32" on No. 70.

Stock Bores — Torque Limiters (No KW I-SS†)

Size No.	Stock Bore	Max. Bore	
		Std. KW*	Shallow KW*
TT25	½	¾	1
TT35	¾	1 1/16	1 1/4
TT50	1	1 1/4	2
TT70	1 1/8	2 1/4	3

† Additional SS See List Price Alterations

* KW To Be Cut Central w/Threaded Spline

Standard Keyways

Torque-Limiter Bore	Keyway	Torque-Limiter Bore	Keyway
½-¾	1/8 x 1/8	1 1/16-1 1/4	3/8 x 3/8
¾-1	3/16 x 3/16	1 1/8-2 1/4	1/2 x 1/2
1 1/16-1 1/4	1/4 x 1/8	2 1/8-2 3/4	5/8 x 5/8
1 1/8-1 1/2	5/16 x 5/16	3 1/16-3	3/4 x 3/4

Bored to Size Torque Limiters w/Std. KW & I-SS†

Size No.	Finished Bores												
	½	¾	1	1 1/8	1 1/4	1 1/2	1 3/4	2	2 1/8	2 1/4	2 1/2	2 3/4	
TT25													
TT35			1										
TT50				1	1 1/8	1 1/4	1 1/2	1 3/4	2				
TT70									1 1/8	1 1/2	1 3/4	2	2 1/8

† KW Same as Std. Listed in Tables Above. Additional S.S. See List Price

Unit Size	Min. Allowable Sprocket Teeth and Length of Bushing Req'd for Chain Number											
	Sprocket Pitch	35	41	40	50	60	80	100	120	140	160	
TT25	Min. Teeth	STK. >	25	19	19	16
	Bush. Lght. Req'd.	MTO ψ	25	19	19	16
TT35	Min. Teeth	STK. >	35	25	26	21	18	15
	Bush. Lght. Req'd.	MTO ψ	33	25	26	21	18	15
TT50	Min. Teeth	STK. >	48	35	35	29	25	19
	Bush. Lght. Req'd.	MTO ψ	46	35	35	29	25	19
TT70	Min. Teeth	STK. >	48	38	33	26	21	18	16	14
	Bush. Lght. Req'd.	MTO ψ	48	38	33	26	21	18	16	14

★ Min. number of teeth on sprocket stocked by factory which can be used w/Torque-Limiter clutch.

ψ Min. number of teeth on made-to-order sprocket which will permit chain to clear friction disc.

* Use one 3/8" long bushing and one 1/2" long.

◆ Use two 1/2" long bushings.

UNIT TT50

Sprocket Size
40TTA35-50
50TTA30-50
50TTA32-50
60TTA25-50
60TTA26-50
60TTA28-50
60TTA30-50
80TTA20-50
80TTA22-50
80TTA24-50

UNIT TT70

Sprocket Size
60TTA36-70
80TTA26-70
80TTA28-70
80TTA30-70
80TTA36-70
100TTA22-70
100TTA24-70

SPARE PARTS

TT25 TT50 TT35 TT70	QTY. REG.*
PRESSURE PLATE	2
FRICTION DISC	2
ADJ. NUT ASSY. & S.S.	1
ADJ. TENSION NUT	3
HUB	1

* PER UNIT



WARNING & SAFETY REMINDER

Safety must be considered a basic factor in machinery operation at all times. Most accidents are the result of carelessness or negligence. All rotating power transmission products are potentially dangerous and must be guarded by the contractor, installer, purchaser, owner, and user as required by applicable laws, regulations, standards, and good safety practice. Additional specific information must be obtained from other sources including the latest editions of American Society of Mechanical Engineers; Standard A.N.S.I. B15.1. A copy of this standard may be obtained from the American Society of Mechanical Engineers at 345 East 47th Street, New York, NY 10017 (212-705-7722).

It is the responsibility of the contractor, installer, purchaser, owner, and user to install, maintain, and operate the parts or components manufactured and supplied by  Sprocket & Gear, Inc., in such a manner as to comply with the Williams-Steiger Occupational Safety Act and with all state and local laws, ordinances, regulations, and the American National Standard Institute Safety Code.

CAUTION

Guards, access doors, and covers must be securely fastened before operating any equipment.

If parts are to be inspected, cleaned, observed, or general maintenance performed, **the motor driving the part or components is to be locked out electrically in such a manner that it cannot be started by anyone**, however remote from the area. Failure to follow these instructions may result in personal injury or property damage.

WARNING

NOTE: CATALOG DIMENSIONS

Every effort is made to keep all catalog dimensions and styles current in the catalog, however from time to time, it is necessary because of manufacturing changes to alter stock products dimensionally.

If any stock product dimension or style shown in this catalog is critical to your application please consult factory for certification.



The
New York Blower
Company®

7660 QUINCY STREET—WILLOWBROOK, ILLINOIS 60521-5596
TEL: (630) 794-5700 • FAX: (630) 794-5776 • WEB: <http://www.nyb.com> • E-MAIL: nyb@nyb.com

INSTALLATION
MAINTENANCE,
OPERATING
INSTRUCTIONS

IM-140

PRESSURE BLOWERS TYPE HP PRESSURE BLOWERS



⚠ WARNING

THIS FAN HAS MOVING PARTS THAT CAN CAUSE SERIOUS BODILY INJURY. BEFORE OPERATING OR STARTING MAINTENANCE READ THE INSTALLATION AND MAINTENANCE INSTRUCTIONS AND THE AMCA SAFETY PRACTICES MANUAL PROVIDED WITH THIS FAN.

DURING OPERATION

- 1. KEEP BODY, HANDS, AND FOREIGN OBJECTS AWAY FROM THE INLET, THE OUTLET, AND THE OTHER MOVING PARTS OF THE FAN SUCH AS SHAFTS, BELTS, AND PULLEYS.**
- 2. DO NOT OPERATE AT EXCESSIVE SPEEDS OR TEMPERATURES.**

BEFORE STARTING MAINTENANCE WORK:

LOCK POWER SUPPLY IN OFF POSITION AND IMMOBILIZE FAN WHEEL.

98-0250

A WORD ABOUT SAFETY

The above **WARNING** decal appears on all **nyb** fans. Air moving equipment involves electrical wiring, moving parts, sound, and air velocity or pressure which can create safety hazards if the equipment is not properly installed, operated and maintained. To minimize this danger, follow these instructions as well as the additional instructions and warnings on the equipment itself.

All installers, operators and maintenance personnel should study AMCA Publication 410, "Recommended Safety Practices for Air Moving Devices", which is included as part of every shipment. Additional copies can be obtained by writing to New York Blower Company, 7660 Quincy St., Willowbrook, IL 60521.

ELECTRICAL DISCONNECTS

Every motor driven fan should have an independent disconnect switch to isolate the unit from the electrical supply. It should be near the fan and must be capable of being locked by maintenance personnel while servicing the unit, in accordance with OSHA procedures.

MOVING PARTS

All moving parts must have guards to protect personnel. Safety requirements vary, so the number and type of guards needed to meet company, local and OSHA standards must be determined and specified by the user. Never start a fan without having all safety guards installed. Check regularly for damaged or missing guards and do not operate any fan with guards removed. Fans can also become dangerous because of potential "windmilling", even though all electrical power is disconnected. Always block the rotating assembly before working on any moving parts.

SOUND

Some fans can generate sound that could be hazardous to exposed personnel. It is the responsibility of the system designer and user to determine sound levels of the system, the degree of personnel exposure, and to comply with applicable safety requirements to protect personnel from excessive noise. Consult **nyb** for fan sound power level ratings.

AIR PRESSURE AND SUCTION

In addition to the normal dangers of rotating machinery, fans present another hazard from the suction created at the fan inlet. This suction can draw materials into the fan where they become high velocity projectiles at the outlet. It can also be extremely dangerous to persons in close proximity to the inlet, as the forces involved can overcome the strength of most individuals. Inlets and outlets that are not ducted should be screened to prevent entry and discharge of solid objects.

ACCESS DOORS

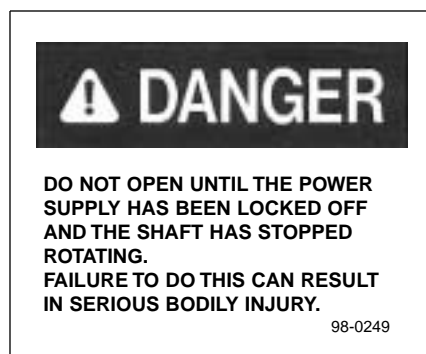

⚠ DANGER

DO NOT OPEN UNTIL THE POWER SUPPLY HAS BEEN LOCKED OFF AND THE SHAFT HAS STOPPED ROTATING. FAILURE TO DO THIS CAN RESULT IN SERIOUS BODILY INJURY.

98-0249

The above **DANGER** decal is placed on all **nyb** cleanout doors. These doors, as well as access doors to the duct system, should never be opened while the fan is in operation. Serious injury could result from the effects of air pressure or suction.

Bolted doors must have the door nuts or fasteners securely tightened to prevent accidental or unauthorized opening.

RECEIVING AND INSPECTION

The fan and accessories should be inspected on receipt for any shipping damage. Turn the wheel by hand to see that it rotates freely and does not bind. If dampers or shutters are provided, check these accessories for free operation of all moving parts.

F.O.B. factory shipping terms require that the receiver be responsible for inspecting the equipment upon arrival. Note damage or shortages on the Bill of Lading and file any claims for damage or loss in transit. **nyb** will assist the customer as much as possible; however, claims must be originated at the point of delivery.

HANDLING AND STORAGE

Fans should be lifted by the base, mounting supports, or lifting eyes only. Never lift a fan by the wheel, shaft, motor, motor bracket, housing inlet, outlet, or any fan part not designed for lifting. A spreader should always be used to avoid damage.

On a direct drive Arrangement 8 fan, lifting holes are provided in the motor base to assist in handling the fan assembly. These lifting holes should be used in conjunction with the lifting eyes when lifting and positioning the fan onto its foundation. A heavy round steel bar or appropriate fixture can be passed through the lifting holes to simplify attachment of the lifting device. Be sure to follow all local safety codes when moving heavy equipment.

Whenever possible, fans and accessories should be stored in a clean, dry location to prevent rust and corrosion of steel components. If outdoor storage is necessary, protection should be provided. Cover the inlet and outlet to prevent the accumulation of dirt and moisture in the housing. Cover motors with waterproof material. Refer to the bearing section for further storage instructions.

Check shutters for free operation and lubricate moving parts prior to storage. Inspect the stored unit periodically. **Rotate the wheel by hand every two weeks to redistribute grease on internal bearing parts.**

FAN INSTALLATION

nyb wheels are dynamically balanced when fabricated. Complete assembled fans are test run at operating speeds to check the entire assembly for conformance to **nyb** vibration limits. Nevertheless, all units must be adequately supported for smooth operation. **Ductwork or stacks should be independently supported as excess weight may distort the fan housing and cause contact between moving parts.** Where vibration isolators are used, consult the **nyb** certified drawing for proper location and adjustment.

Slab-Mounted Units

A correctly designed and level concrete foundation provides the best means of installing floor-mounted fans. The mass of the base must maintain the fan/driver alignment, absorb normal vibration, and resist lateral loads. The overall dimensions of the concrete base should extend at least six inches beyond the base of the fan. The weight of the slab should be two to three times the weight of the rotating assembly, including the motor. The foundation requires firmly anchored fasteners such as the anchor bolts shown in Figure 1.

Move the fan to the mounting location and lower it over the anchor bolts, leveling the fan with shims around the bolts. Fasten the fan securely. When grout is used, shim the fan at least 3/4-inch from the concrete base. (See Figure 1.) When isolation is used, check the **nyb** certified drawing for installation instructions.

Elevated Units

When an elevated or suspended structural steel platform is used, it must have sufficient bracing to support the unit load and prevent side sway. The platform should be of welded construction to maintain permanent alignment of all members.

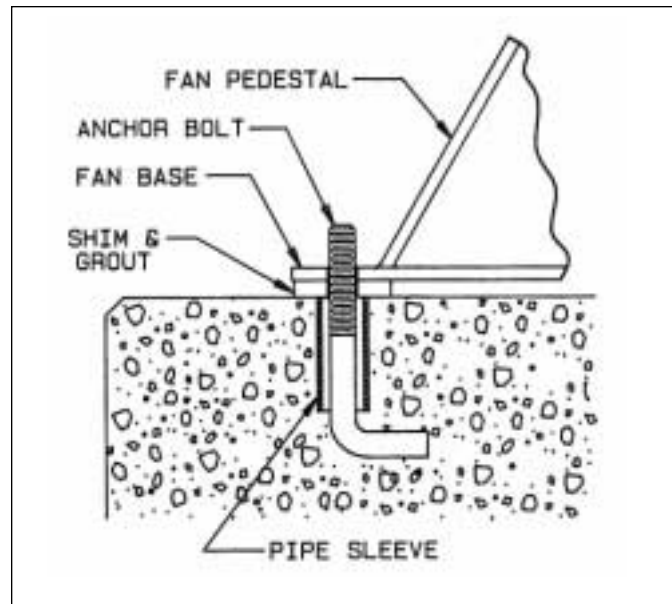

Figure 1

V-BELT DRIVE

Installation

1. Remove all foreign material from the fan and motor shafts. Coat shafts with machine oil for easier mounting. Mount the belt guard backplate at this time if partial installation is required prior to sheave mounting.
2. Mount sheaves on shafts after checking sheave bores and bushings for nicks or burrs. Avoid using force. If resistance is encountered, lightly polish the shaft with emery cloth until the sheave slides on freely. Tighten tapered bushing bolts sequentially so that equal torque is applied to each.
3. Adjust the motor on its base to a position closest to the fan shaft. Install belts by working each one over the sheave grooves until all are in position. Never pry the belts into place. On **nyb** packaged fans, sufficient motor adjustment is provided for easy installation of the proper size belts.
4. Adjust sheaves and the motor shaft angle so that the sheave faces are in the same plane. Check this by placing a straightedge across the face of the sheaves. Any gap between the edge and sheave faces indicates misalignment. Important: This method is only valid when the width of the surface between the belt edge and the sheave face is the same for both sheaves. When they are not equal, or when using adjustable-pitch sheaves, adjust so that all belts have approximately equal tension. Both shafts should be at the right angles to the center belt.

Belt Tensioning

1. Check belt tension with a tensioning gage and adjust using the motor slide base. Excess tension shortens bearing life while insufficient tension shortens belt life, can reduce fan performance and may cause vibration. The lowest allowable tension is that which prevents slippage under full load. Belts may slip during start-up, but slipping should stop as soon as the fan reaches full speed. For more precise tensioning methods, consult the drive manufacturer's literature.
2. Recheck setscrews, rotate the drive by hand and check for rubbing, then complete the installation of the belt guard.

- Belts tend to stretch somewhat after installation. Recheck tension after several days of operation. Check sheave alignment as well as setscrew and/or bushing bolt tightness.

COUPLING

Coupling alignment should be checked after installation and prior to start up. Alignment is set at the factory, but shipping, handling, and installation can cause misalignment. Also check for proper coupling lubrication. For details on lubrication and for alignment tolerances on the particular coupling supplied, see the manufacturer's installation and maintenance supplement in the shipping envelope.

Installation

Most **nyb** fans are shipped with the coupling installed. In cases where the drive is assembled after shipping, install the coupling as follows:

- Remove all foreign material from fan and motor shafts and coat with machine oil for easy mounting of coupling halves.
- Mount the coupling halves on each shaft, setting the gap between the faces specified by the manufacturer. Avoid using force. If mounting difficulty is encountered, lightly polish the shaft with emery cloth until the halves slide on freely.

Alignment

- Align the coupling to within the manufacturer's limits for parallel and angular misalignment (see Figure 2). A dial indicator or laser can also be used for alignment where greater precision is desired. Adjustments should be made by moving the motor to change shaft angle, and by the use of foot shims to change motor shaft height. Do not move the fan shaft or bearing.
- When correctly aligned, install the flexible element and tighten all fasteners in the coupling and motor base. Lubricate the coupling if necessary.
- Recheck alignment and gap after a short period of operation, and recheck the tightness of all fasteners in the coupling assembly.

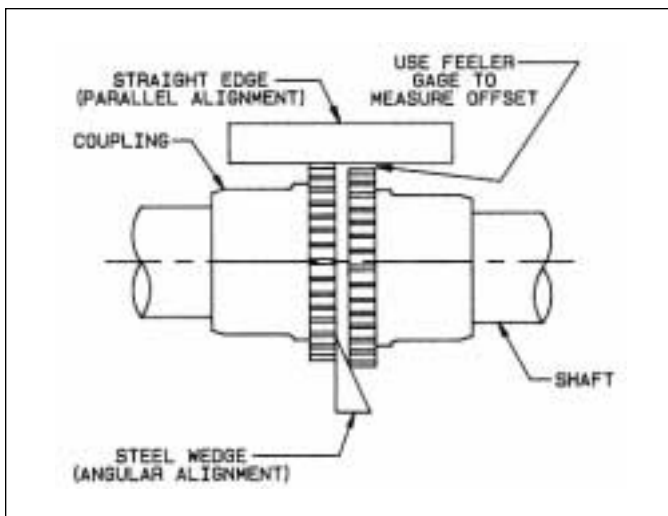

Figure 2

START-UP

Safe operation and maintenance includes the selection and use of appropriate safety accessories for the specific installation. This is the responsibility of the system designer and requires consideration of equipment location and accessibility as well as adjacent components. All safety accessories must be installed properly prior to start-up.

Safe operating speed is a function of system temperature and wheel design. Do not under any circumstances exceed the maximum safe fan speed published in the **nyb** engineering supplement, which is available from your **nyb** field sales representative.

⚠ CAUTION

BEFORE INITIAL OPERATION:

1. **TIGHTEN ALL SET SCREWS IN FAN WHEEL.**
2. **TIGHTEN ALL SET SCREWS IN BEARINGS.**
3. **REPEAT AFTER 8 HOURS OF OPERATION.**
4. **REPEAT AGAIN AFTER TWO WEEKS OPERATION.**

98-0271

Procedure

- If the drive components are not supplied by **nyb**, verify with the manufacturer that the starting torque is adequate for the speed and inertia of the fan.
- Inspect the installation prior to starting the fan. Check for any loose items or debris that could be drawn into the fan or dislodged by the fan discharge. Check the interior of the fan as well. Turn the wheel by hand to check for binding.
- Check drive installation and belt tension.
- Check the tightness of all setscrews, nuts and bolts. When furnished, tighten hub setscrews with the wheel oriented so that the setscrew is positioned underneath the shaft.
- Install all remaining safety devices and guards. Verify that the supply voltage is correct and wire the motor. "Bump" the starter to check for proper wheel rotation.
- Use extreme caution when testing the fan with ducting disconnected. Apply power and check for unusual sounds or excessive vibration. If either exists, see the section on Common Fan Problems. To avoid motor overload, do not run the fan for more than a few seconds if ductwork is not fully installed. On larger fans, normal operating speed may not be obtained without motor overload unless ductwork is attached. Check for correct fan speed and complete installation. Ductwork and guards must be fully installed for safety.
- Setscrews should be rechecked after a few minutes, eight hours and two weeks of operation (see Tables 1 & 2 for correct tightening torques).

NOTE: Shut the fan down immediately if there is any sudden increase in fan vibration.

Table 1 - WHEEL SETSCREW TORQUES

Setscrew Size Diameter (in.)	Carbon Steel Setscrew Torque*	
	lb.-in.	lb.-ft.
1/2	600	50
5/8	--	97
3/4	--	168

* Stainless Steel setscrews are not hardened and should not be tightened to more than 1/2 the values shown.

Table 2 - BEARING SETSCREW TORQUE, lb.-in.

Setscrew Diameter	Manufacturer				
	Link-Belt	Sealmaster	SKF	McGill	Dodge
1/4	90	65	50	85	--
5/16	185	125	165	165	160

Note: Split pillow block bearings are fixed to the shaft with tapered sleeves and generally do not have setscrews.

FAN MAINTENANCE

nyb fans are manufactured to high standards with quality materials and components. Proper maintenance will ensure a long and trouble-free service life.

Do not attempt any maintenance on a fan unless the electrical supply has been completely disconnected and locked. In many cases, a fan can windmill despite removal of all electrical power. The rotating assembly should be blocked securely before attempting maintenance of any kind.

The key to good fan maintenance is regular and systematic inspection of all fan parts. Inspection frequency is determined by the severity of the application and local conditions. Strict adherence to an inspection schedule is essential.

Regular fan maintenance should include the following:

1. Check the fan wheel for any wear or corrosion, as either can cause catastrophic failures. Check also for the build-up of material which can cause unbalance resulting in vibration, bearing wear and serious safety hazards. Clean or replace the wheel as required.
2. Check the V-belt drive for proper alignment and tension (see section on V-belt drives). If belts are worn, replace them as a set, matched to within manufacturer's tolerances. Lubricate the coupling of direct-drive units and check for alignment (see section on couplings).
3. Lubricate the bearings, but do not over lubricate (see the bearing section for detailed specifications).
4. Ceramic-felt shaft seals require no maintenance, although worn seals should be replaced. When lip-type shaft seals are provided, lubricate them with "NEVER-SEEZ" or other anti-seize compound.
5. During any routine maintenance, all setscrews and bolts should be checked for tightness. See the table for correct torques.
6. When installing a new wheel, the proper wheel-to-inlet clearance must be maintained (see Figure 3).

WHEEL BALANCE

Airstreams containing particulate or chemicals can cause abrasion or corrosion of the fan parts. This wear is often uneven and can lead to significant wheel unbalance over time. When such wear is discovered, a decision must be made as to whether to rebalance or replace the wheel.

The soundness of all parts should be determined if the original thickness of components is reduced. Be sure there is no hidden structural damage. The airstream components should also be cleaned to remove any build-up of foreign material. Specialized equipment can be used to rebalance a cleaned wheel that is considered structurally sound.

Balance weights should be rigidly attached at a point that will not interfere with the housing nor disrupt airflow. Remember that centrifugal forces can be extremely high at the outer radius of a fan wheel. Welding is the preferred method of balance weight attachment. Be sure to ground the welder directly to the fan wheel. Otherwise, the welding current could pass through the fan bearings and damage them.

WHEEL-INLET CLEARANCE

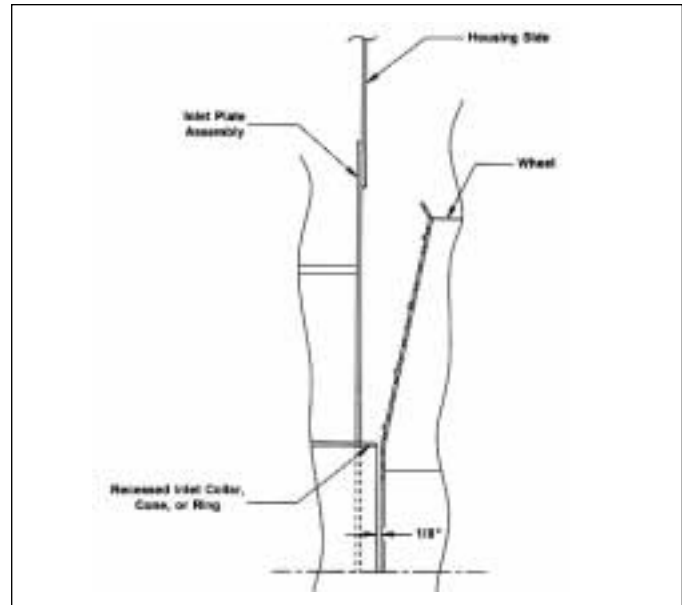

Figure 3

BEARINGS

Storage

Any stored bearing can be damaged by condensation caused by temperature variations. Therefore, **nyb** fan bearings are filled with grease at the factory to exclude air and moisture. Such protection is adequate for shipment and subsequent immediate installation.

For long term or outdoor storage, mounted bearings should be regreased and wrapped with plastic for protection. **Rotate the fan wheel by hand at least every two weeks to redistribute grease on internal bearing parts.** Each month the bearings should be purged with new grease to remove condensation, since even a filled bearing can accumulate moisture. Use caution when purging, as excessive pressure can damage the seals. Rotate the shaft while slowly adding grease.

Operation

Check the setscrew torque before start-up (see table for correct values). Since bearings are completely filled with grease at the factory, they may run at an elevated temperature during initial operation. Surface temperatures may reach 180°F. and grease may bleed from the bearing seals. This is normal and no attempt should be made to replace lost grease. Bearing surface temperatures will decrease when the internal grease quantity reaches a normal operating level. Relubrication should follow the recommended schedule.

Lubrication

Use the table for relubrication scheduling according to operating speed and shaft diameter. Bearings should be lubricated with a premium quality lithium-based grease conforming to NLGI Grade 2. Examples are:

Mobil - Mobilith AW2 Chevron - Amolith #2
 Texaco - Premium RB Shell - Alvania #2

These greases are for bearing surface temperatures of 40°F. to 180°F. For surface temperatures of 181°F. to 230°F. use Mobilith SHC220.

Do not use "high temperature" greases, as many are not formulated to be compatible with fan bearings.

Add grease to the bearing while running the fan or rotating the shaft by hand. Be sure all guards are in place if lubrication is performed while the fan is operating. Add just enough grease to cause a slight purging at the seals. Except on split pillowblocks. Completely filled bearings will run hotter until a sufficient amount of grease is purged out of the seals.

Split pillowblock bearings (Link-Belt P-LB6800 & P-LB6900, SKF SAF 22500, Dodge SAF-XT) should be cleaned and repacked at approximately every eighth lubrication interval. This requires removal of the bearing cap. Clean out old grease and repack the bearing with fresh grease. Pack the bearing fully and fill the housing reservoir to the bottom of the shaft on both sides of the bearing. Replace the bearing cap, being careful not to mix caps as they are not interchangeable from one bearing to another. **Do not over lubricate.**

BEARING LUBRICATION INTERVAL [months]

RPM Shaft	1 - 500	501- 1000	1001- 1500	1501- 2000	2001- 2500	2501- 3000	3001- 3500	3501- 4000
1 7/16	6	6	5-6	4-6	4-6	3-5	2-4	2-4
	6	4	4	2	2	1	1	1
1 11/16	6	6	4-6	4-6	2-4	2-4	2	1-2
	6	4	2	1	1	1	1-2	1-2
2 3/16			6	4-6	4	2-4	2	--
2 7/16			6	4-6	4	2-4	2	--
2 15/16			4-6	4-6	2-4	2	1-2	--

Ball Bearings & Split Split Pillowblock →  ← Non-Split Pillowblock Spherical Roller Bearings

NOTE:

- These are general recommendations only; specific manufacturer's recommendations may vary slightly.
- Assumes clean environment, -20°F. to 120°F.
 - Consult The New York Blower Company for operation below -20°F. ambient.
 - Ambient temperatures greater than 120°F. will shorten bearing life.
 - Under extremely dirty conditions, lubricate more frequently.
- Assumes horizontal mounting configuration. For vertically mounted applications, lubricate twice as frequently.

COMMON FAN PROBLEMS

Excessive Vibration

A common complaint regarding industrial fans is "excessive vibration". **nyb** is careful to ensure that each unit is precisely balanced prior to shipment; however, there are many other causes of vibration including:

- Loose mounting bolts, setscrews, bearings or couplings.
- Misalignment or excessive wear of couplings or bearings.
- Misaligned or unbalanced motor.
- Bent shaft due to mishandling or material impact.
- Accumulation of foreign material on the wheel.
- Excessive wear or erosion of the wheel.
- Excessive system pressure or restriction of airflow due to closed dampers.
- Inadequate structural support, mounting procedures or materials.
- Externally transmitted vibration.

Inadequate Performance

- Incorrect testing procedures or calculations.
- Fan running too slowly.
- Fan wheel rotating in wrong direction or installed backwards on shaft.
- Wheel not properly centered relative to inlet cone.
- Damaged or incorrectly installed cut off sheet or diverter.
- Poor system design, closed dampers, air leaks, clogged filters, or coils.
- Obstructions or sharp elbows near inlets.
- Sharp deflection of airstream at fan outlet.

Excessive Noise

- Fan operating near "stall" due to incorrect system design or installation.
- Vibration originating elsewhere in the system.
- System resonance or pulsation.
- Improper location or orientation of fan intake and discharge.
- Inadequate or faulty design of supporting structures.
- Nearby sound reflecting surfaces.
- Loose accessories or components.
- Loose drive belts.
- Worn bearings.

Premature Component Failure

- Prolonged or major vibration.
- Inadequate or improper maintenance.
- Abrasive or corrosive elements in the airstream or surrounding environment.
- Misalignment or physical damage to rotating components or bearings.
- Bearing failure from incorrect or contaminated lubricant or grounding through the bearings while arc welding.
- Excessive fan speed.
- Extreme ambient or airstream temperatures.
- Improper belt tension.
- Improper tightening of wheel setscrews.

REPLACEMENT PARTS

It is recommended that only factory-supplied replacement parts be used. **nyb** fan parts are built to be fully compatible with the original fan, using specific alloys and tolerances. These parts carry a standard **nyb** warranty.

When ordering replacement parts, specify the part name, **nyb** shop and control number, fan size, type, rotation (viewed from drive end), arrangement and bearing size or bore. Most of this information is on the metal nameplate attached to the fan base.

For assistance in selecting replacement parts, contact your local **nyb** representative or visit: <http://www.nyb.com>.

Example: Part required: Wheel/shaft assembly
 Shop/control number: B-10106-100
 Fan description: Size 2206A10 Pressure Blower
 Rotation: Clockwise
 Arrangement: 4

Suggested replacement parts include:

Wheel	Component parts: Damper
Shaft ●	Motor
Bearings*	Coupling*
Shaft Seal*	Sheaves*
	V-Belts*

● For Arrangement 1/8 fan only.

SPECIFY ROTATION AS VIEWED FROM DRIVE SIDE



ARROW INDICATES COUNTER CLOCKWISE ROTATION

**Arrangement 4
Pressure Blower**

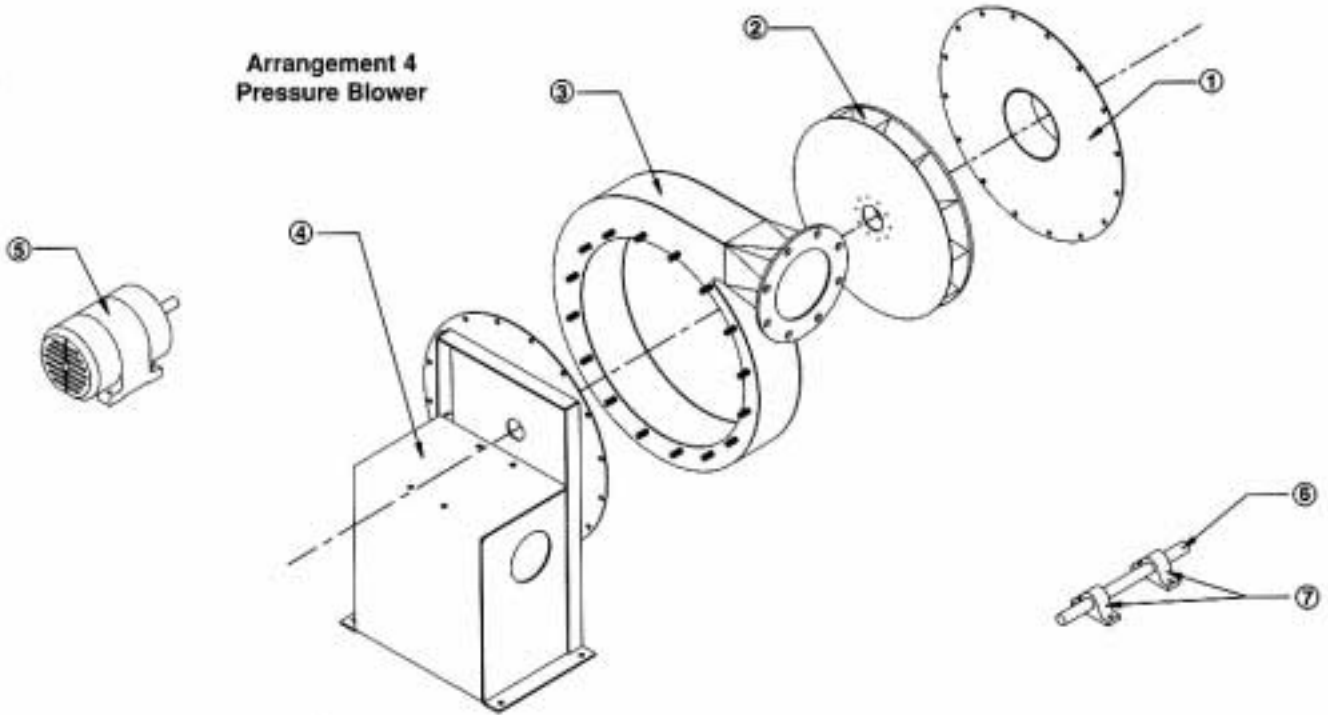

**Arrangement 4
Type HP
Pressure Blower**

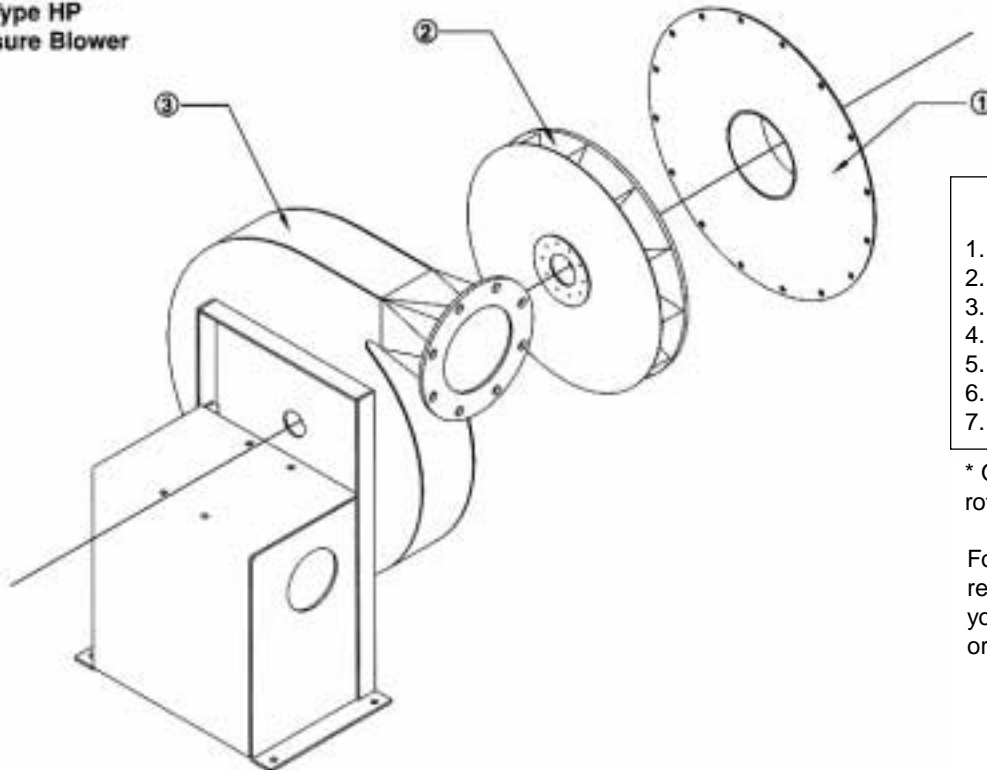

Parts List

- 1. Inlet Plate Assembly
- 2. Wheel*
- 3. Housing*
- 4. Pedestal Assembly
- 5. Motor
- 6. Shaft
- 7. Bearings

* Order for parts must specify rotation.

For assistance in selecting replacement parts, contact your local **nyb** representative or visit: <http://www.nyb.com>.