

"HV" SERIES CYCLONE
MODELS HV51 TO HV144

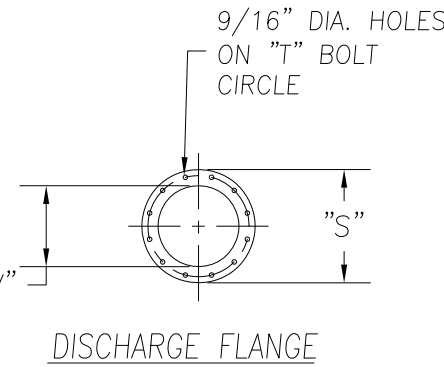

- STANDARD FEATURES**
1. ALL WELDED 12GA. OR 10GA. CONSTRUCTION
 2. TOOL-LESS CLEAN-OUT PORT
 3. MATERIAL: CARBON STEEL, STAINLESS STEEL, ALUMINUM
 4. PAINT: STANDARD IS WHITE OR ENVIROGREEN INDUSTRIAL ENAMEL

- OPTIONAL FEATURES**
1. STRUCTURAL SUPPORTS
 2. FLANGED INLET AND OUTLET
 3. FLANGED CONSTRUCTION
 4. WEAR LINER

CAMCORP MODELS HV51 TO HV144

MODEL NUMBER	CFM RANGE	DIMENSIONS (INCHES)																				EST. INSTALLED WT.		
		A	B	C	D	E	F	G	H	J	K	L	M	N	P	R	S	T	V	W	X		Y	Z
HV51	6,258-8,867	51	206	60	75	22 1/2	49 1/2	24	25 1/2	25 1/2	13	31 1/2	34 1/2	169	6	29 3/4	14 1/2	12 5/8	10	13	16	31	195	1,300
HV54	7,217-10,220	54	214	64 1/2	75	25	49 1/2	26	27	27	13 1/2	33	36	173 1/2	6	31 1/4	14 1/2	12 5/8	10	15	18	31	201 3/4	1,435
HV60	8,604-12,192	60	240 1/2	75 1/2	89	26 1/2	49 1/2	29	30	30	15	36	39	195 1/2	6	34 1/4	14 1/2	12 5/8	10	15	19	37	227 1/4	1,697
HV68	11,063-15,696	68	270	91	101	29	49 1/2	33	34	34	17	40	43	220 1/2	6	38 1/4	14 1/2	12 5/8	10	17	21	42	255 1/2	2,100
HV74	13,275-18,811	74	292	102	108	32 1/2	49 1/2	36	37	37	18 1/2	43	46	237	6	41 1/4	14 1/2	12 5/8	10	19	24	45	276	2,370
HV85	17,745-25,145	85	333 1/2	122 1/2	125	36 1/2	49 1/2	41	42	42 1/2	21	48 1/2	51 1/2	271	6	46 1/4	14 1/2	12 5/8	10	22	27	52	315	3,105
HV96	22,886-32,430	96	378	117 1/2	142	41 1/2	77	47	48	48	24	54	57	307	6	52 1/4	21 1/4	19 1/2	16	25	31	59	357	5,580
HV108	28,675-40,632	108	422 1/2	140	159	46 1/2	77	53	54	54	27	60	63	343	6	58 1/4	21 1/4	19 1/2	16	28	35	66	399	6,890
HV120	35,603-50,450	120	469	162 1/2	178	51 1/2	77	59	60	60	30	66	69	380 1/2	6	64 1/4	21 1/4	19 1/2	16	32	39	74	442 1/2	8,395
HV132	42,733-60,533	132	513	185	195	56	77	65	66	66	33	72	75	416 1/2	6	70 1/4	21 1/4	19 1/2	16	34	42	81	484 1/2	9,690
HV144	50,533-71,605	144	557 1/2	207 1/2	212	61	77	71	72	72	36	78	81	452 1/2	6	76 1/4	21 1/4	19 1/2	16	37	46	88	526 1/2	11,372

9732 PFLUMM, LENEXA, KS 66215 PHONE: 913-831-0740 • FAX: 913-831-9271

TITLE: "HV" SERIES CYCLONE
MODELS HV51 TO HV144

DATE: 08/16/99	DRN BY: DOTY	DWG. NO.: CYCLONE-HV	P.S.: 24-00	REV.: #2
-------------------	-----------------	-------------------------	----------------	-------------