

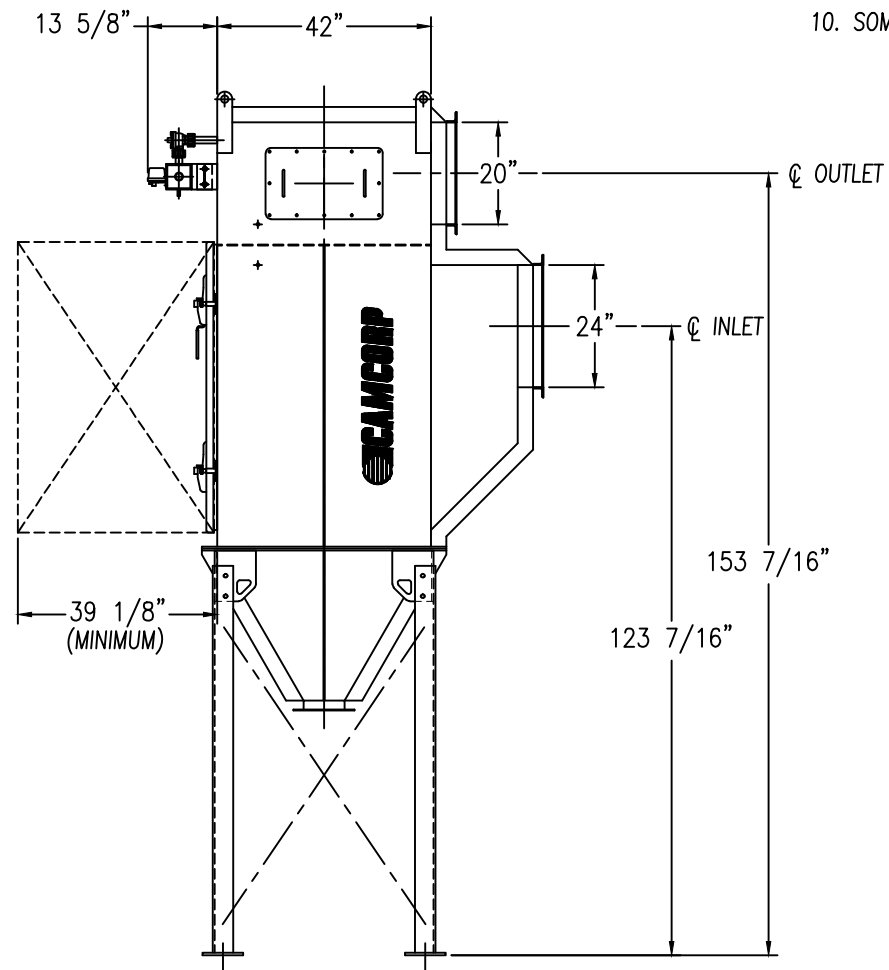

STANDARD FEATURES

1. ALL WELDED HEAVY-DUTY CARBON STEEL CONSTRUCTION
2. HOUSING RATED FOR: +/-25" W.C.
3. INTERIOR DIRTY AIR PLENUM PRIMED ONLY
4. EXTERIOR PRIMED & FINISHED PAINTED WHITE INDUSTRIAL ENAMEL
5. (4) CARTRIDGE ELEMENTS FACTORY INSTALLED
STANDARD 1,300 SQ.FT. OF 80/20 CELLULOSE/SYNTHETIC BLEND FILTER MEDIA
OPTIONAL 980 SQ.FT. OF POLY-EL SPUN BOND POLYESTER FILTER MEDIA
6. APPROX. AIR CONSUMPTION OF 2.5 SCF PER VALVE PER PULSE OF CLEAN, DRY, OIL FREE COMPRESSED AIR AT 80-90 PSIG
7. NEMA 4 ELECTRICAL ENCLOSURES (TIMER ENCLOSURE SHIPS LOOSE FOR REMOTE MOUNTING)
8. 120/1/60 VAC REQUIRED
9. ESTIMATED INSTALLED WEIGHT = 1,885 LBS
10. SOME FIELD ASSEMBLY REQUIRED

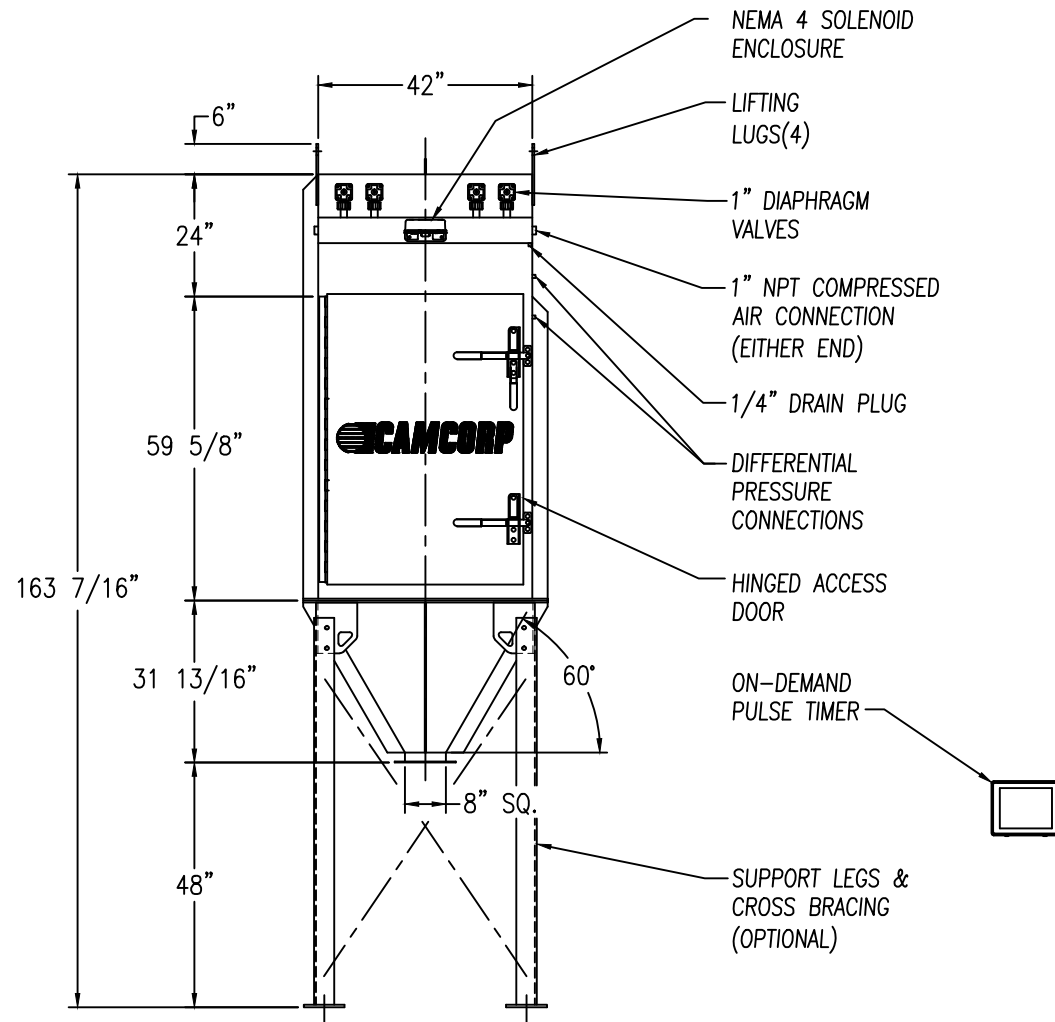

OPTIONAL FEATURES

1. STRUCTURAL SUPPORTS
2. SERVICE PLATFORMS
3. EXPLOSION VENTING
4. EXPLOSION-PROOF ELECTRICALS
5. HIGHER PRESSURE/VACUUM RATINGS
6. FILTER MEDIAS/PRE-FILTER OVERBAGS

REV 1	REISSUED	DB
		
CAMCORP INC. <small>www.camcorpinc.com PHONE: 913-831-0740 FAX: 913-831-9271</small>		
TITLE: VERTICAL CARTRIDGE DUST COLLECTOR MODEL CA4-1D-SH		
DATE: 9/01/09	DRN BY: DB	DWG. NO.: CAT-CA4-1D-SH
P.S.:	REV.:	1