

HIGH INLET WITH INTERNAL BAFFLES

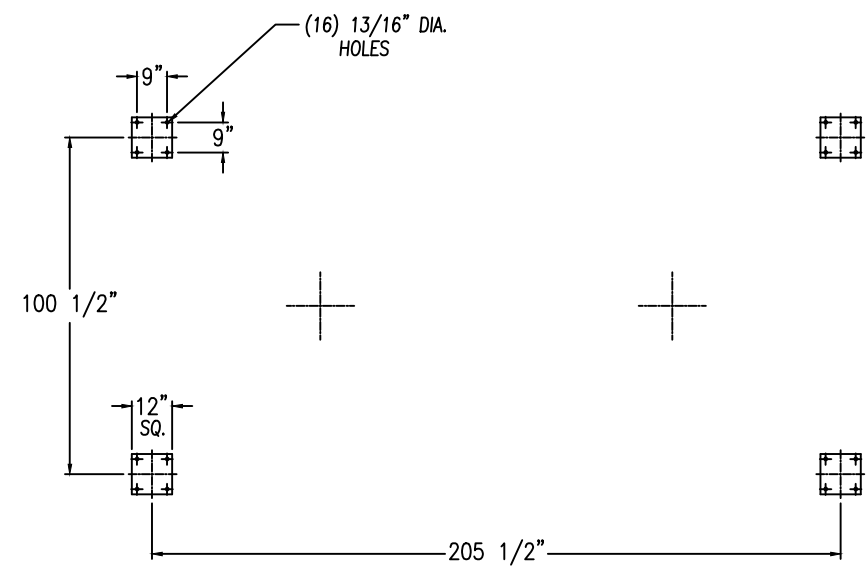

ANCHOR PLAN

STANDARD FEATURES

1. ALL WELDED HEAVY-DUTY CARBON STEEL CONSTRUCTION
2. HOUSING RATED FOR: +/-25" W.C.
3. INTERIOR DIRTY AIR PLENUM PRIMED ONLY
4. EXTERIOR PRIMED & FINISHED PAINTED WHITE INDUSTRIAL ENAMEL
5. (50) CARTRIDGE ELEMENTS FACTORY INSTALLED
STANDARD 16,250 SQ.FT. OF 80/20 CELLULOSE/SYNTHETIC BLEND FILTER MEDIA
OPTIONAL 12,250 SQ.FT. OF POLY-EL SPUN BOND POLYESTER FILTER MEDIA
6. APPROX. AIR CONSUMPTION OF 12.0 SCF PER VALVE PER PULSE OF CLEAN, DRY, OIL FREE COMPRESSED AIR AT 80-90 PSIG
7. NEMA 4 ELECTRICAL ENCLOSURES (TIMER ENCLOSURE SHIPS LOOSE FOR REMOTE MOUNTING)
8. 120/1/60 VAC REQUIRED
9. ESTIMATED INSTALLED WEIGHT = 12,470 LBS
10. SOME FIELD ASSEMBLY REQUIRED

OPTIONAL FEATURES

1. STRUCTURAL SUPPORTS
2. SERVICE PLATFORMS
3. EXPLOSION VENTING
4. EXPLOSION-PROOF ELECTRICALS
5. HIGHER PRESSURE/VACUUM RATINGS
6. FILTER MEDIAS/PRE-FILTER OVERBAGS

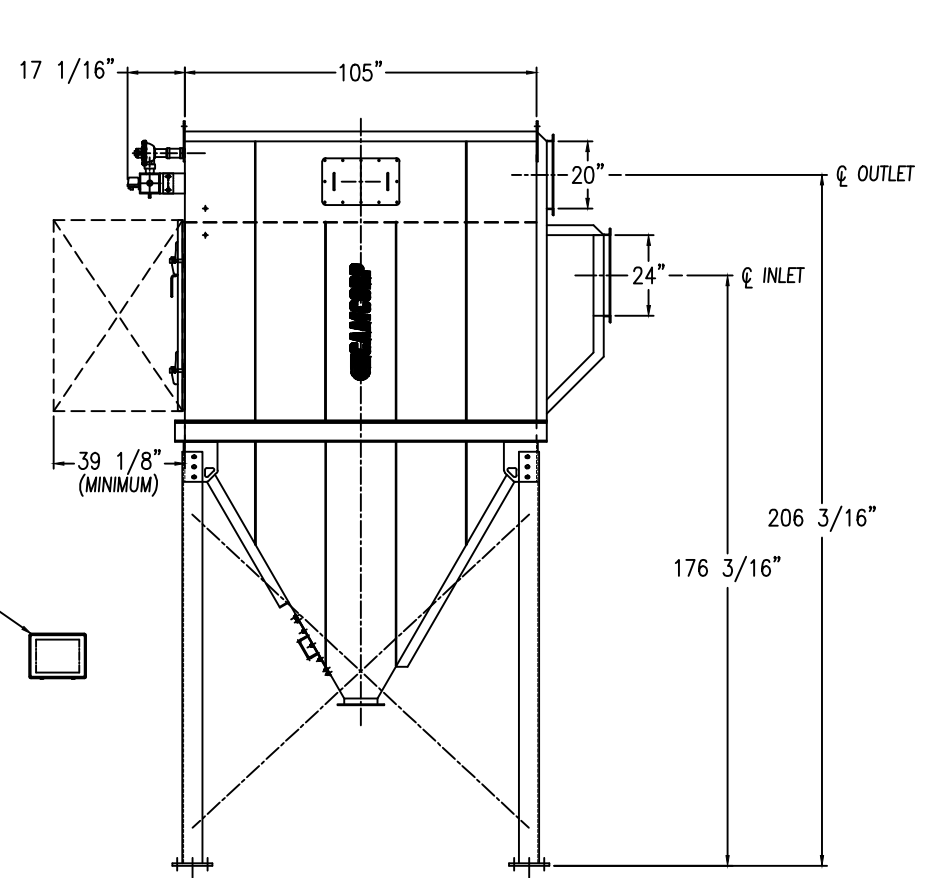
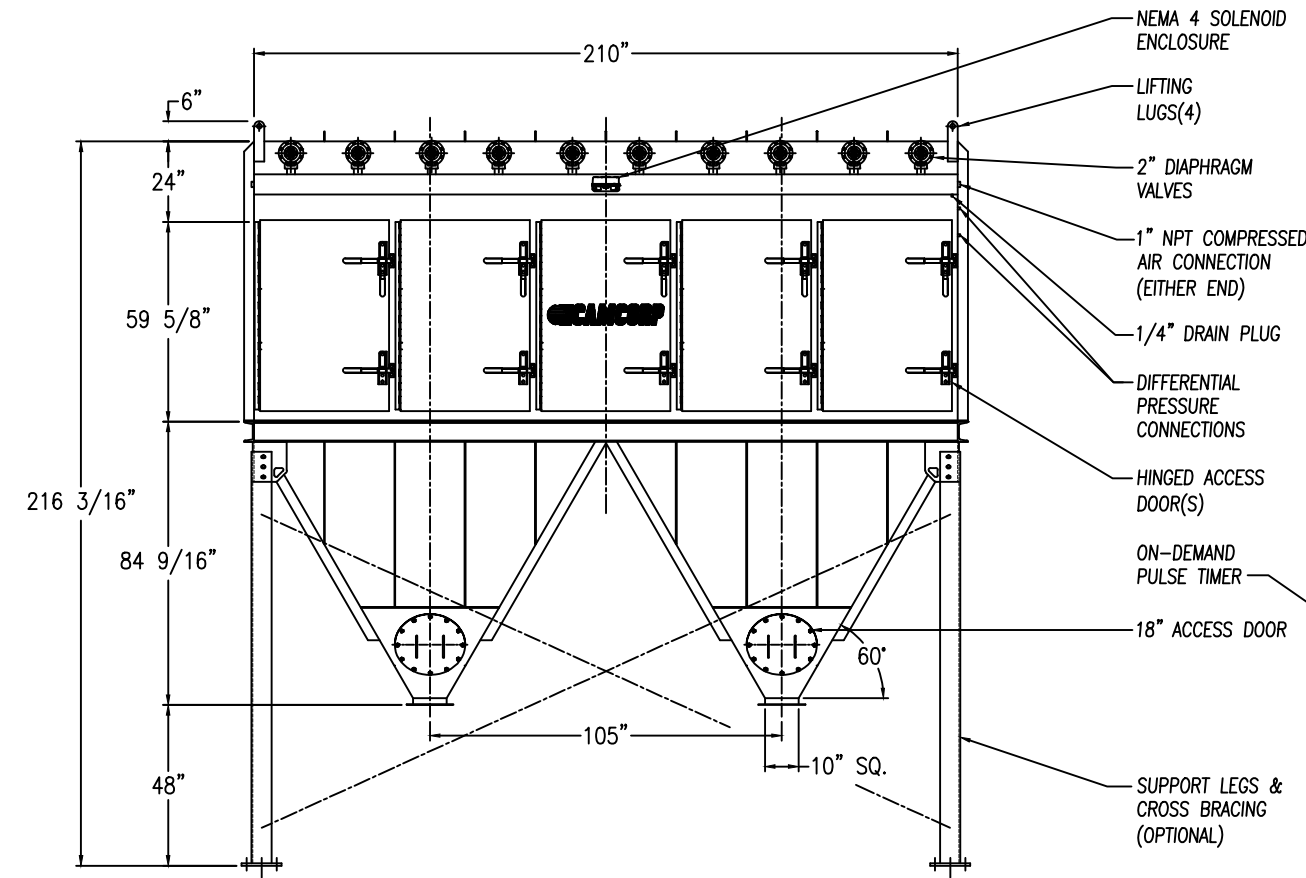

REV 1	REISSUED	DB
 CAMCORP INC. <small>PHONE: 913-831-0740 • FAX: 913-831-9271</small>		
TITLE: VERTICAL CARTRIDGE DUST COLLECTOR MODEL CA50-5D-MH		
DATE: 9/01/09	DRN BY: DB	DWG. NO.: CAT-CA50-5D-MH
P.S.:	REV.:	1