

STANDARD FEATURES

1. ALL WELDED HEAVY-DUTY CARBON STEEL CONSTRUCTION
2. HOUSING RATED FOR: +/-25" W.C.
3. INTERIOR DIRTY AIR PLENUM PRIMED ONLY
4. EXTERIOR PRIMED & FINISHED PAINTED WHITE INDUSTRIAL ENAMEL
5. (6) CARTRIDGE ELEMENTS FACTORY INSTALLED
STANDARD 1,950 SQ.FT. OF 80/20 CELLULOSE/SYNTHETIC BLEND FILTER MEDIA
OPTIONAL 1,470 SQ.FT. OF POLY-EL SPUN BOND POLYESTER FILTER MEDIA
6. APPROX. AIR CONSUMPTION OF 2.5 SCF PER VALVE PER PULSE OF CLEAN, DRY, OIL FREE COMPRESSED AIR AT 80-90 PSIG
7. NEMA 4 ELECTRICAL ENCLOSURES (TIMER ENCLOSURE SHIPS LOOSE FOR REMOTE MOUNTING)
8. 120/1/60 VAC REQUIRED
9. ESTIMATED INSTALLED WEIGHT = 2,550 LBS
10. SOME FIELD ASSEMBLY REQUIRED

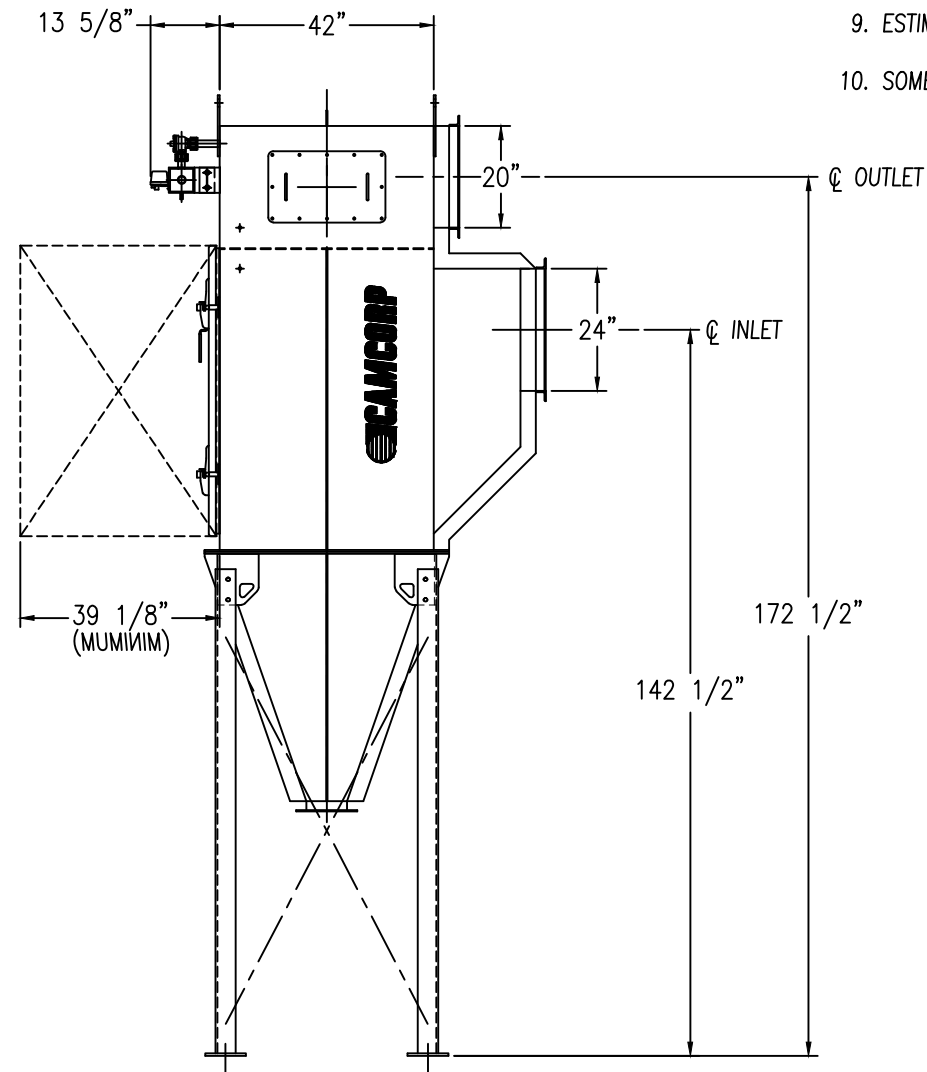
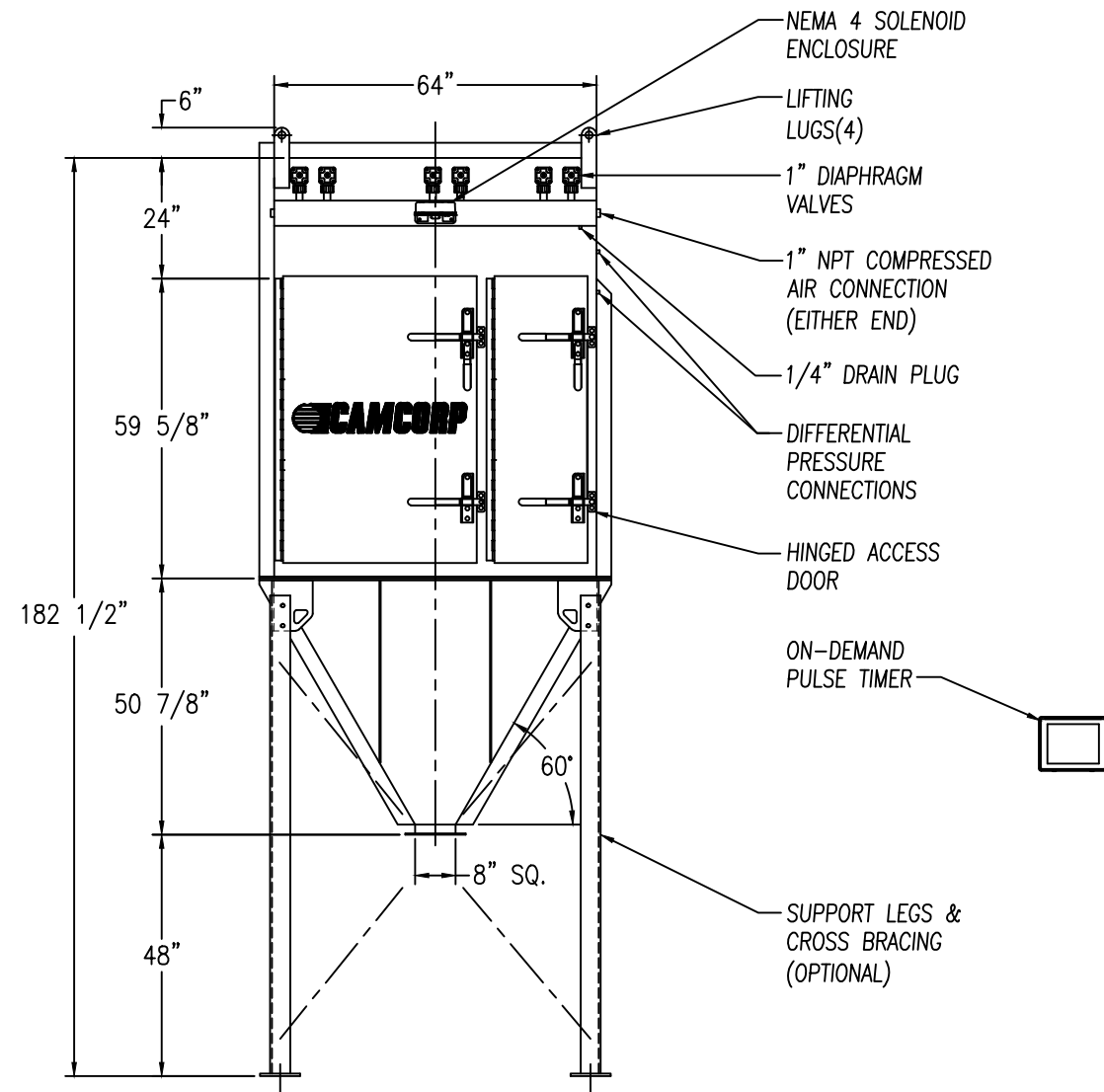

OPTIONAL FEATURES

1. STRUCTURAL SUPPORTS
2. SERVICE PLATFORMS
3. EXPLOSION VENTING
4. EXPLOSION-PROOF ELECTRICALS
5. HIGHER PRESSURE/VACUUM RATINGS
6. FILTER MEDIAS/PRE-FILTER OVERBAGS

CAMCORP

www.camcorpinc.com

CAMCORP INC.
PHONE: 913-831-0740 • FAX: 913-831-9271

TITLE: VERTICAL CARTRIDGE DUST COLLECTOR
MODEL CA6-1.5D-SH

DATE: 05/11/10	DRN BY: DB	DWG. NO.: CAT-CA6-1.5D-SH	P.S.:	REV.:
-------------------	---------------	------------------------------	-------	-------