

CAMCORP MODELS 6PRT37 TO 10PRT180								
MODEL NUMBER	FILTER MEDIA (SQ. FT.)	QUAN. OF BAGS	BAG LENGTH (IN FT.)	NO. OF VALVES	DIMENSIONS (INCHES)			EST. INSTALLED WT.
					A	B	C	
6PRT37	355	37	6	7	144 1/2	62	47	2462
8PRT37	474		8		168 1/2			2836
6PRT44	422	44	6	8	150 1/4	68	52	2821
8PRT44	563		8		174 1/4			3236
6PRT52	499	52	6	8	156	72	57	3788
8PRT52	667		8		180			4354
6PRT61	586	61	6	9	162	79	62	4322
8PRT61	781		8		186			4942
6PRT70	682	70	6	9	169 3/4	87	69	5263
8PRT70	909		8		193 3/4			5984
6PRT80	768	80	6	10	173 1/4	90	72	5792
8PRT80	1024		8		197 1/4			6548
6PRT91	874	91	6	11	189	96	77	6648
8PRT91	1165		8		213			7464
10PRT91	1456	102	10	11	137	104	84	8284
8PRT102	1306		8		221			8370
10PRT102	1632	10	245	9264				
8PRT114	1459	114	8	12	224 5/8	108	87	8851
10PRT114	1824		10		248 5/8			9792
8PRT127	1626	127	8	13	229 3/8	113	91	9568
10PRT127	2032		10		253 3/8			10565
8PRT140	1792	140	8	13	237 3/8	121	98	10608
10PRT140	2240		10		261 3/8			11680
8PRT154	1971	154	8	14	240 3/4	124	101	11369
10PRT154	2464		10		264 3/4			12485
8PRT169	2163	169	8	15	246 1/2	130	106	12245
10PRT169	2704		10		270 1/2			13426
8PRT180	2304	180	8	16	248 7/8	132	108	12647
10PRT180	2880		10		272 7/8			13860

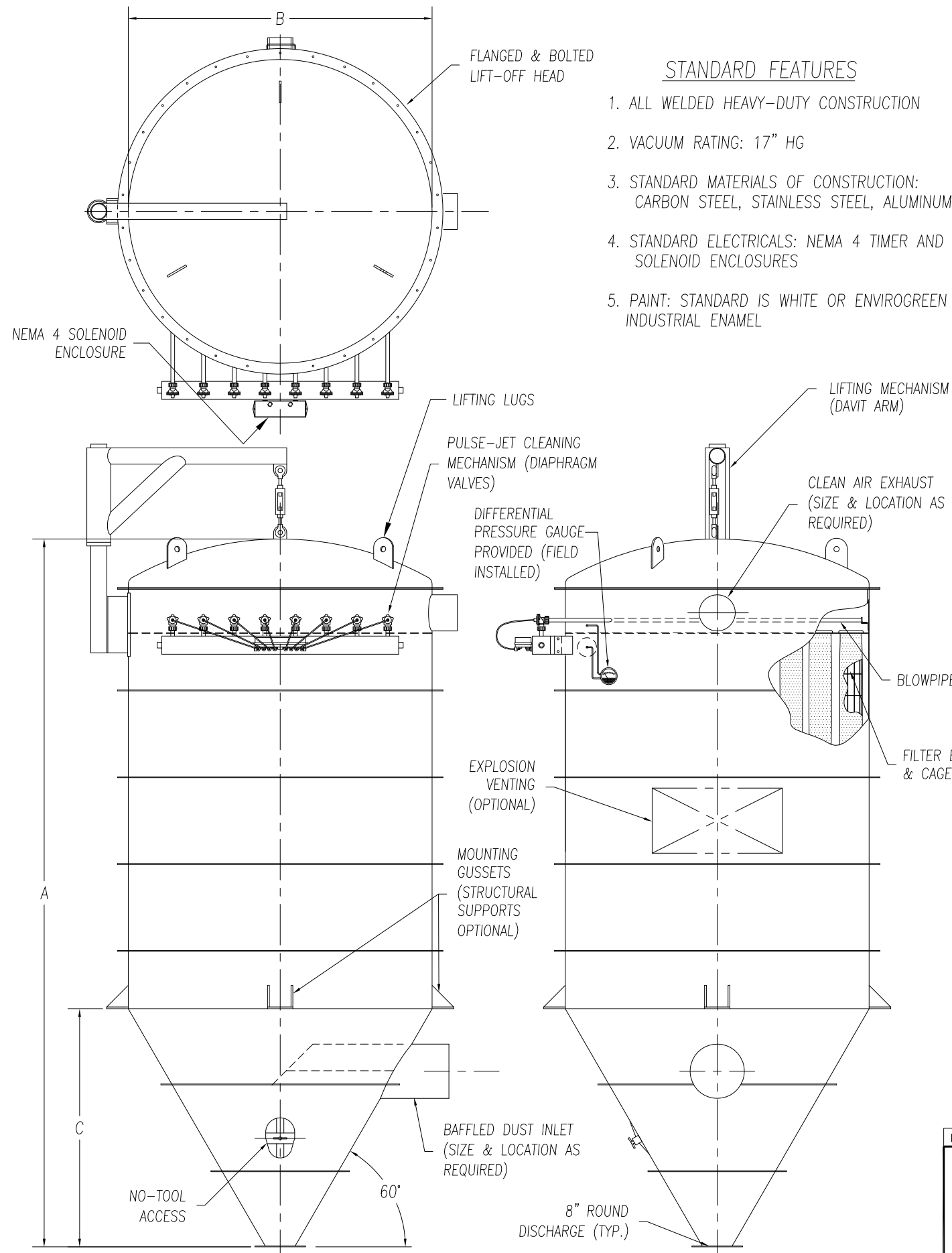

STANDARD FEATURES

1. ALL WELDED HEAVY-DUTY CONSTRUCTION
2. VACUUM RATING: 17" HG
3. STANDARD MATERIALS OF CONSTRUCTION: CARBON STEEL, STAINLESS STEEL, ALUMINUM
4. STANDARD ELECTRICALS: NEMA 4 TIMER AND SOLENOID ENCLOSURES
5. PAINT: STANDARD IS WHITE OR ENVIROGREEN INDUSTRIAL ENAMEL

OPTIONAL FEATURES

1. STRUCTURAL SUPPORTS
2. SERVICE PLATFORMS
3. EXPLOSION VENTING
4. EXPLOSION-PROOF ELECTRICALS
5. HIGHER PRESSURE/VACUUM RATING
6. BIN VENT STYLE
7. WIDE BAG SPACING
8. WALK-IN CLEAN AIR PLENUM

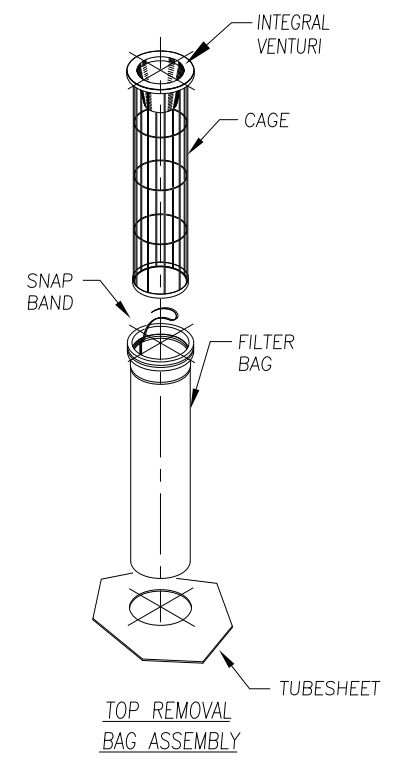

TOP REMOVAL BAG PNEUMATIC RECEIVER (37 TO 180 BAGS)

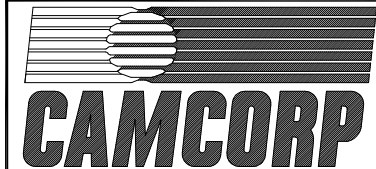
REV. 1	10/04/01	CHG'D OUTLET
 CAMCORP <small>9732 PFLUMM, LENEXA, KS 66215 PHONE: 913-831-0740 • FAX: 913-831-9271</small>		
TITLE: TOP REMOVAL BAG PNEUMATIC RECEIVER MODEL 6PRT37 TO 10PRT180 (37 TO 180 BAG)		
DATE: 8-10-99	DRN BY: DES	DWG. NO.: CAT-PRT2
P.S.: 36-00	REV.: #1	