

CAMCORP MODELS 45SFPRB37-35P TO 84SFPRB180-45P

MODEL NUMBER	FILTER AREA (SQ. FT.)			QUAN. OF CARTS	CARTRIDGE LENGTH (INCHES)	DIMENSIONS (INCHES)				EST. INSTALLED WT.
	35 PLEATS	45 PLEATS	60 PLEATS			A	B	C	D	
45SFPRB114	2519	3237	4377	114	45	177 5/8	108	87	90 5/8	7159
60SFPRB114	3534	4548	6053		60	193 5/8			106 5/8	7796
84SFPRB114	5107	6486	N/A		84	216 5/8			129 5/8	8671
45SFPRB127	2806	3607	4877	127	45	182 3/8	113	91	91 3/8	7939
60SFPRB127	3937	5067	6743		60	197 3/8			106 3/8	8613
84SFPRB127	5689	7226	N/A		84	221 3/8			130 3/8	9535
45SFPRB140	3094	3976	5376	140	45	190 3/8	121	98	92 3/8	8871
60SFPRB140	4340	5586	7434		60	205 3/8			107 3/8	9595
84SFPRB140	6272	7966	N/A		84	229 3/8			131 3/8	10587
45SFPRB154	3403	4373	5913	154	45	193 3/4	124	101	92 3/4	9327
60SFPRB154	4774	6144	8177		60	208 3/4			107 3/4	10080
84SFPRB154	6899	8762	N/A		84	232 3/4			131 3/4	11106
45SFPRB169	3735	4799	6489	169	45	199 1/2	130	106	93 1/2	10081
60SFPRB169	5239	6743	8974		60	214 1/2			108 1/2	10878
84SFPRB169	7571	9616	N/A		80	238 1/2			132 1/2	11961
45SFPRB180	3978	5112	6912	180	45	201 7/8	132	108	93 7/8	10439
60SFPRB180	5580	7182	9558		60	216 7/8			108 7/8	11256
84SFPRB180	8064	10242	N/A		80	240 7/8			132 7/8	12365

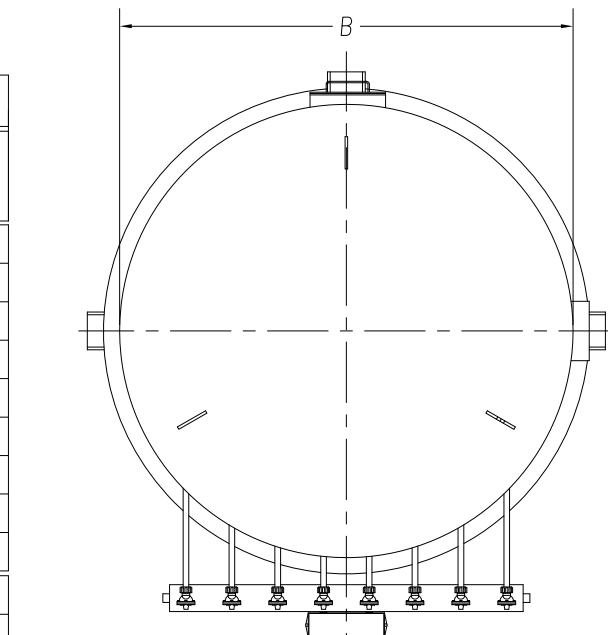

- STANDARD FEATURES**
1. ALL WELDED HEAVY-DUTY CONSTRUCTION
 2. VACUUM RATING: 17" HG
 3. STANDARD MATERIALS OF CONSTRUCTION: CARBON STEEL, STAINLESS STEEL, ALUMINUM
 4. STANDARD ELECTRICALS: NEMA 4 TIMER AND SOLENOID ENCLOSURES
 5. PAINT: STANDARD IS WHITE OR ENVIROGREEN INDUSTRIAL ENAMEL

- OPTIONAL FEATURES**
1. STRUCTURAL SUPPORTS
 2. SERVICE PLATFORMS
 3. EXPLOSION VENTING
 4. EXPLOSION-PROOF ELECTRICALS
 5. HIGHER PRESSURE/VACUUM RATING
 6. BIN VENT STYLE
 7. WIDE CARTRIDGE SPACING

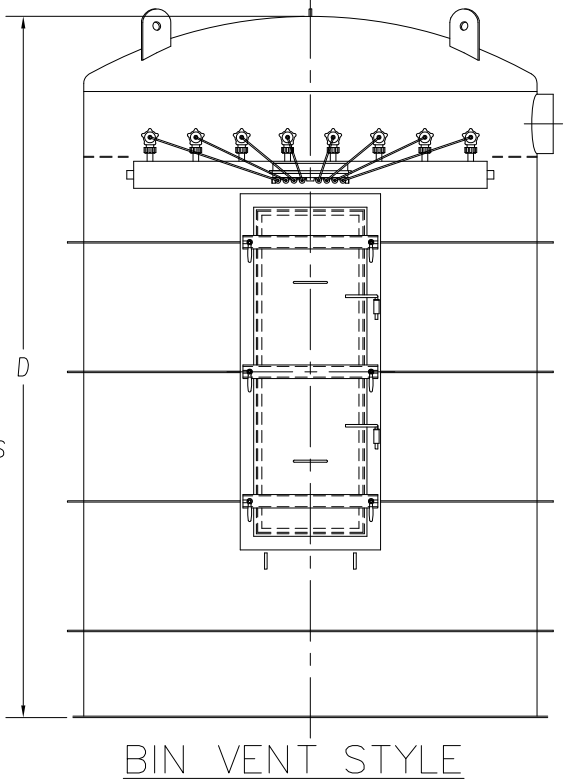
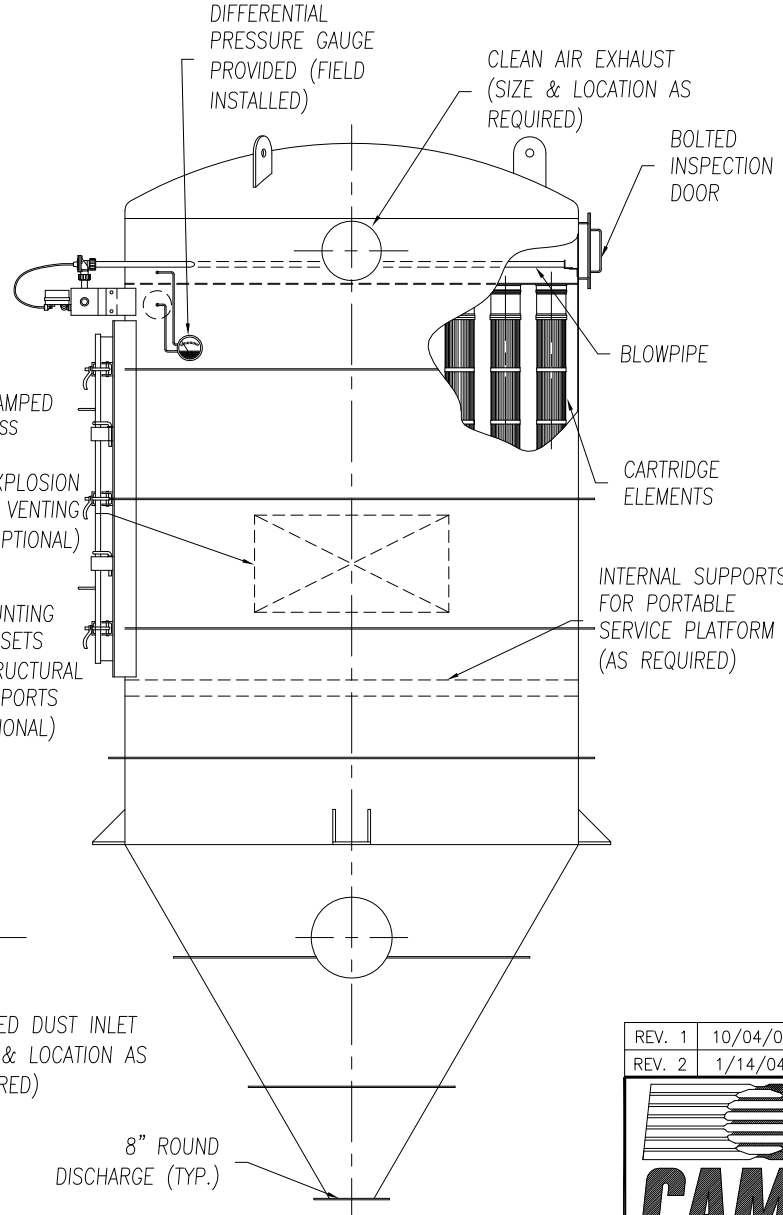
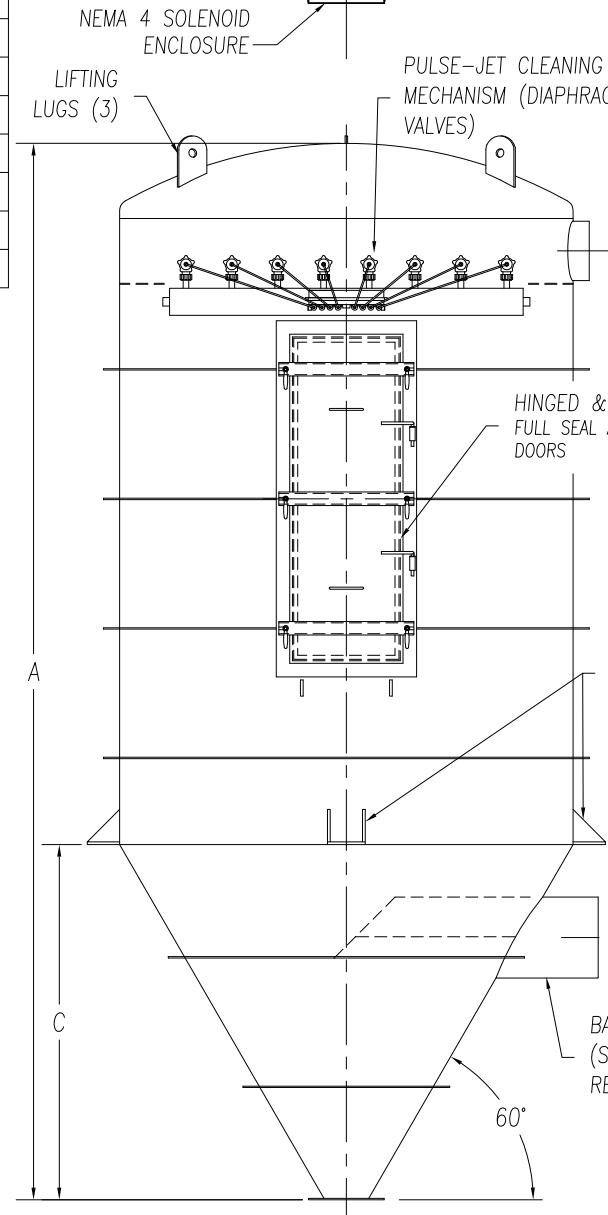
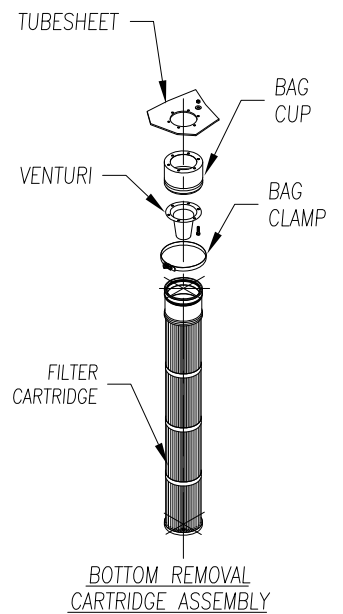

BOTTOM REMOVAL CARTRIDGE PNEUMATIC RECEIVER (114 TO 180 CARTRIDGES)

REV. 1	10/04/01	ADDED DRAWINGS, CHG'D. TITLE
REV. 2	1/14/04	CHG'D. FILTER AREA SQ. FT.

CAMCORP
 9732 PFLUMM, LENEXA, KS 662153 PHONE: 913-831-0740 • FAX: 913-831-9271

TITLE: BOTTOM REMOVAL CARTRIDGE PNEUMATIC RECEIVER
 MODEL 45SFPRB114 TO 84SFPRB180 (114 TO 180 CARTRIDGE)

DATE: 8-10-99	DRN BY: DES	DWG. NO.: CAT-SFPRB2r02	P.S.: 36-00	REV.: #1
---------------	-------------	-------------------------	-------------	----------