

CAMCORP MODELS 8TRW8X64 TO 16TRW12X256									
MODEL NUMBER	FILTER MEDIA (SQ. FT.)	QUAN. OF BAGS	BAG LENGTH (IN FT.)	DIMENSIONS (INCHES)					EST. INSTALLED WT.
				A	B	C	D	E	
8TRW8X64	819	64	8	251	71 1/2	71 1/2	55	100	4082
8TRW10X64	1024		10	299				124	4718
8TRW12X64	1229		12	347				148	5590
8TRW8X72	922	72	8	258 1/2	71 1/2	80	62 1/2	100	5021
8TRW10X72	1152		10	306 1/2				124	5686
8TRW12X72	1382		12	354 1/2				148	6687
8TRW8X80	1024	80	8	266	71 1/2	88 1/2	70	100	5431
8TRW10X80	1280		10	314				124	6145
8TRW12X80	1536		12	362				148	7201
9TRW8X81	1037	81	8	258 1/2	80	80	62 1/2	100	5545
9TRW10X81	1296		10	306 1/2				124	6261
9TRW12X81	1555		12	354 1/2				148	7385
9TRW8X90	1152	90	8	266	80	88 1/2	70	100	5983
9TRW10X90	1440		10	314				124	6749
9TRW12X90	1728		12	362				148	7933
9TRW8X99	1267	99	8	273 1/2	80	97	77 1/2	100	6439
9TRW10X99	1584		10	321 1/2				124	7255
9TRW12X99	1901		12	369 1/2				148	8552
10TRW8X100	1280	100	8	266	88 1/2	88 1/2	70	100	6406
10TRW10X100	1600		10	314				124	7223
10TRW12X100	1920		12	362				148	8464
10TRW8X110	1408	110	8	273 1/2	88 1/2	97	77 1/2	100	6882
10TRW10X110	1760		10	321 1/2				124	7751
10TRW12X110	2112		12	369 1/2				148	9109
10TRW8X120	1536	120	8	280 1/2	88 1/2	105 1/2	84 1/2	100	7334
10TRW10X120	1920		10	328 1/2				124	8245
10TRW12X120	2304		12	376 1/2				148	9680
11TRW8X121	1549	121	8	273 1/2	97	97	77 1/2	100	7341
11TRW10X121	1936		10	321 1/2				124	8270
11TRW12X121	2323		12	369 1/2				148	9735
11TRW8X132	1690	132	8	280 1/2	97	105 1/2	84 1/2	100	7814
11TRW10X132	2112		10	328 1/2				124	8786
11TRW12X132	2534		12	376 1/2				148	10331
12TRW8X144	1843	144	8	280 1/2	105 1/2	105 1/2	84 1/2	100	8270
12TRW10X144	2304		10	328 1/2				124	9280
12TRW12X144	2765		12	376 1/2				148	10891
12TRW8X156	1997	156	8	288	105 1/2	114	92	100	8954
12TRW10X156	2496		10	336				124	10022
12TRW12X156	2995		12	384				148	11694
13TRW8X169	2163	169	8	288	114	114	92	100	9453
13TRW10X169	2704		10	336				124	10538
13TRW12X169	3245		12	384				148	12312
13TRW8X182	2330	182	8	295 1/2	114	122 1/2	99 1/2	100	10019
13TRW10X182	2912		10	343 1/2				124	11202
13TRW12X182	3494		12	391 1/2				148	13062

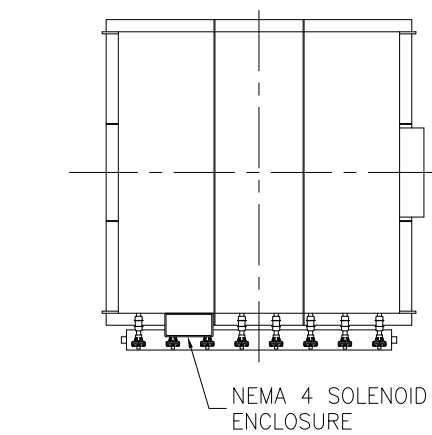

### STANDARD FEATURES

1. ALL WELDED HEAVY-DUTY CONSTRUCTION
2. PRESSURE/VACUUM RATING: +/-20"W.C.
3. STANDARD MATERIALS OF CONSTRUCTION: CARBON STEEL, STAINLESS STEEL, ALUMINUM
4. STANDARD ELECTRICALS: NEMA 4 TIMER AND SOLENOID ENCLOSURES
5. PAINT: STANDARD IS WHITE OR ENVIROGREEN INDUSTRIAL ENAMEL

### OPTIONAL FEATURES

1. STRUCTURAL SUPPORTS
2. SERVICE PLATFORMS
3. EXPLOSION VENTING
4. EXPLOSION-PROOF ELECTRICALS
5. HIGHER PRESSURE/VACUUM RATING
6. WIDE BAG SPACING

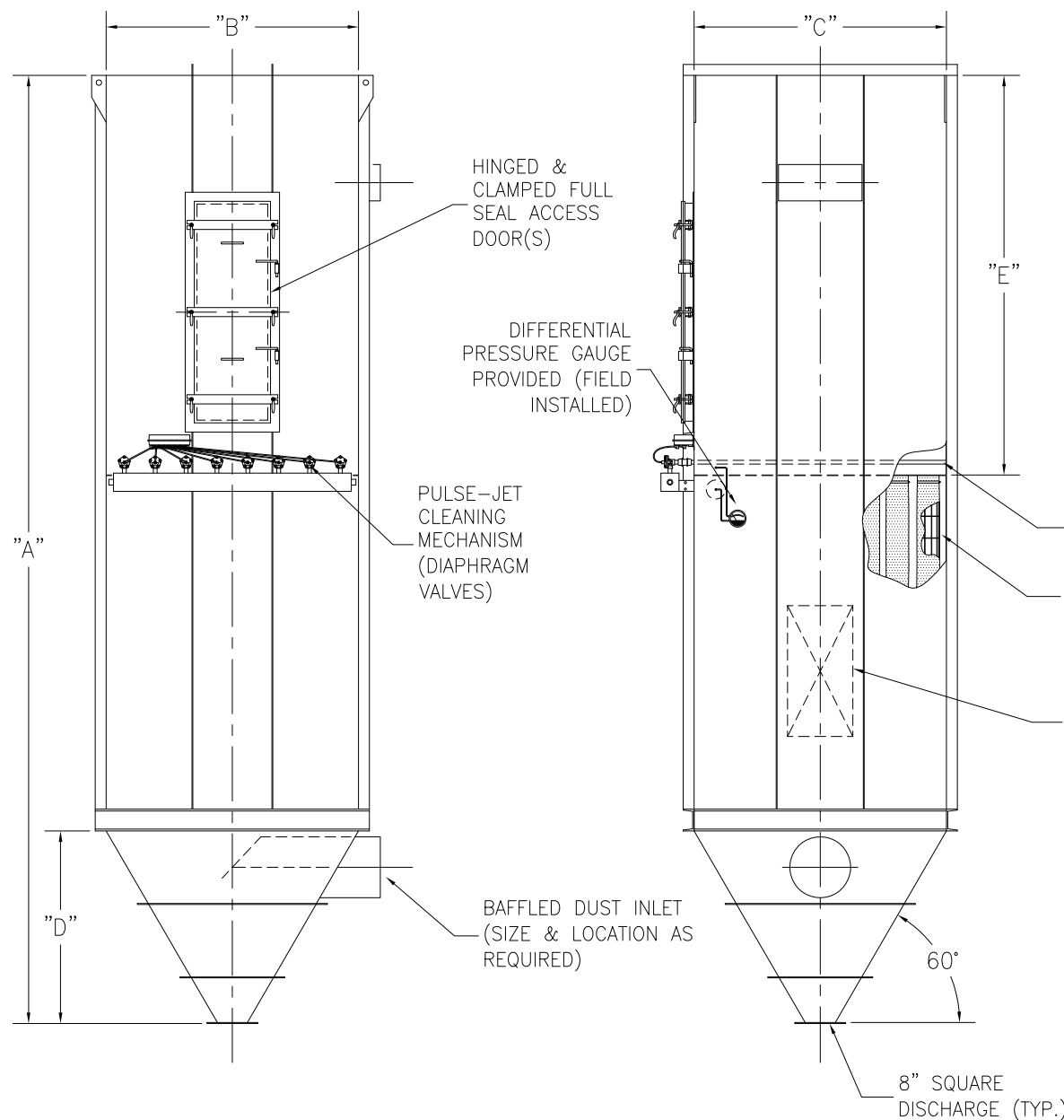
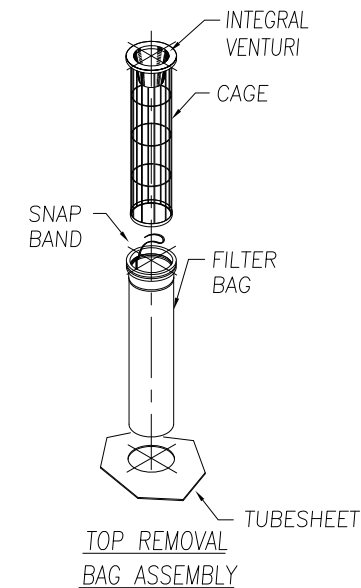

WALK-IN BAG REMOVAL  
DUST COLLECTOR  
( 64 TO 182 BAGS )

9732 PFLUMM, LENEXA, KS. 66215      PHONE: 913-831-0740      FAX: 913-831-9271

TITLE: WALK-IN TOP REMOVAL BAG DUST COLLECTORS  
MODEL 8TRW8X64 TO 12TRW12X182 (64 TO 182 BAGS)

DATE: 10/29/01	DRN BY: DOTY	DWG. NO.: CAT-WIT1	P.S.: 48-00	REV.:
-------------------	-----------------	-----------------------	----------------	-------