

("P") 7/16" DIA. HOLES
EQUALLY SPACED ON "R" DIA. B.C.

INLET/OUTLET FLANGE DETAIL

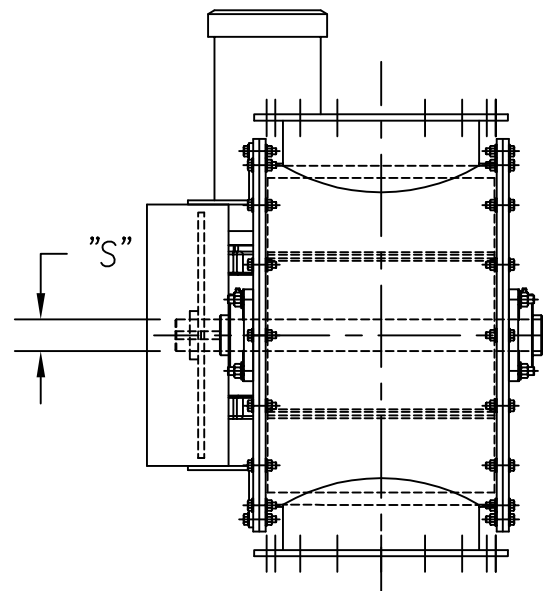
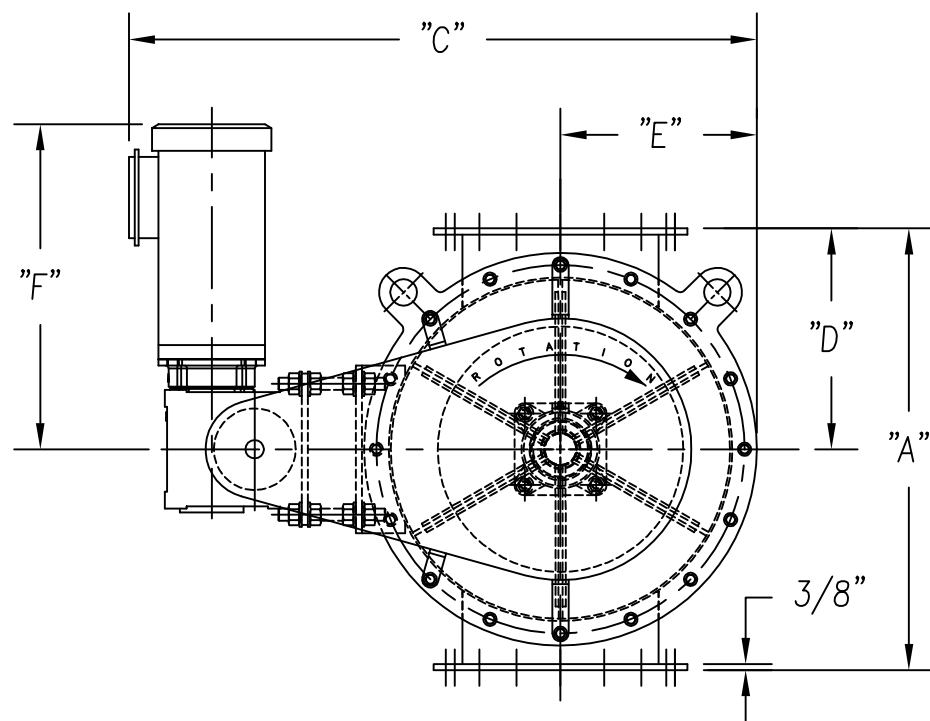

CAMCORP MODELS 8FR TO 30FR

MODEL NUMBER	DIMENSIONS (INCHES)																CFR	MIN MAX RPM	STANDARD HP	EST. WT. LBS.
	A	B	C	D	E	F	G	H	J	K	L	M	N	P	R	S				
8FR	19	19 1/2	29 1/8	9 1/2	8	17 1/2	5 3/4	7 7/8	11 5/8	10 5/8	4	8	11 1/2	8	10	1 1/2	0.64	12-24	3/4	250
10FR	23	22	34 1/4	11 1/2	10	20	6 5/8	8 7/8	13 1/8	10 5/8	4	10	13 1/2	12	12	1 15/16	1.40	12-24	1	400
12FR	27	24 3/8	38 3/8	13 1/2	12	20	7 13/16	10 1/16	14 5/16	10 5/8	4	12	15 1/2	12	14	1 15/16	2.50	12-24	1-1/2	500
14FR	27	27 3/8	41 3/4	13 1/2	12	22 3/4	9 5/16	11 9/16	15 13/16	12 3/8	4	14	17 1/2	16	16	1 15/16	3.00	12-24	2	550
16FR	33 1/4	31 1/2	48	16 5/8	15 1/8	22 3/4	9 13/16	12 9/16	18 15/16	14 3/8	6	16	19 1/2	16	18	2 7/16	5.60	12-24	2	870
20FR	37 1/4	35 7/8	52	18 5/8	17 1/8	22 3/4	12	14 3/4	21 1/8	14 3/8	6	20	23 1/2	24	22	2 7/16	9.10	12-24	3	1020
24FR	43 1/4	39 7/8	58	21 5/8	20 1/8	22 3/4	14	16 3/4	23 1/8	14 7/8	6	24	27 1/2	24	26 1/8	2 7/16	15.50	12-24	3	1250
30FR	61 1/2	46 1/2	79 5/8	30 3/4	29	23 1/2	17	20 1/2	26	16 1/4	6	30	33 1/2	32	32 1/8	2 15/16	42.40	12-24	5	2150

STANDARD FEATURES

1. HOUSING: ALL WELDED CARBON STEEL, ROUND FLANGED INLET AND OUTLET, REMOVABLE SIDE PLATES, LIFTING LUGS.
2. ROTOR: STEEL, 6-VANE OPEN END, SANDWICHED FLEXIBLE NEOPRENE BLADES, 4-BOLT FLANGE BEARINGS.
3. DRIVE: TEFC RATED C-FACE MOTOR, RIGHT-ANGLE HEAVY-DUTY GEAR REDUCER, INDUSTRIAL ROLLER CHAIN DRIVE, TOTALLY ENCLOSED OSHA DRIVE GUARD.
4. PAINT: STANDARD IS WHITE OR ENVIROGREEN INDUSTRIAL ENAMEL (GUARD: SAFETY YELLOW).

OPTIONAL FEATURES

1. STAINLESS STEEL CONSTRUCTION.
2. SQUARE FLANGED INLET AND OUTLET.
3. ALTERNATIVE FLEXIBLE BLADE MATERIALS.
4. EXP. PROOF RATED C-FACE MOTOR.
5. EXTENDED TAIL SHAFT.
6. ALTERNATIVE PAINT COLORS AVAILABLE.

3	ADDED 14" AIRLOCK	DC	4/25/14
2	REVERSED ROTATION ARROW	DS	10/22/09
1	ADDED 8" AIRLOCK	DB	8/24/05
REV	DRAWING STATUS	BY	DATE

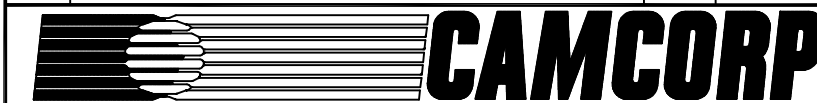

9732 PFLUMM, LENEXA, KS 66215 PHONE: 913-831-0740 FAX: 913-831-9271

This drawing and the solutions/designs are the property of CAMCORP, Inc. and are furnished only for informational purposes on a confidential basis. Reproduction, publishing, or other disclosures are on a "NEED TO KNOW" basis only. Any other reproduction requires written authorization by a corporate officer.

TITLE: "FR" SERIES FABRICATED AIRLOCKS
MODEL 8FR TO 30FR

DATE: 4/25/05	DRAWN: DB	DRAWING NUMBER: AIRLOCK-FR	REVISION: 3
---------------	-----------	----------------------------	-------------