

TUBE & PIPE

Vacuum Bends

Standard 45° Y's

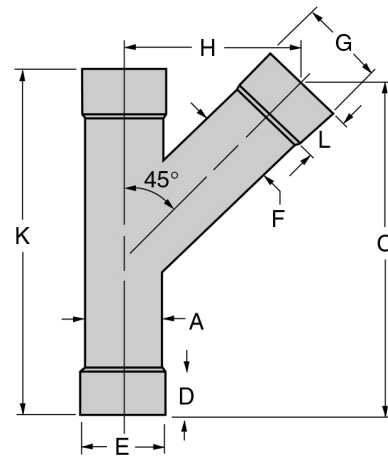

SIZE (IN.)	A-O.D. (IN.)	GAUGE	C (IN.)	D (IN.)	E-I.D. (IN.)	F-O.D. (IN.)	GAUGE	G-I.D. (IN.)	H (IN.)	K (IN.)	L (IN.)
2 ½	2 ½	16	9-9/32	1 ¼	2 ½	2 ½	16	2 ½	4-11/16	9 ½	1 ¼
2 ½ x 2 ½	2 ½	16	9-9/32	1 ¼	2 ½	2 ½	16	2 ½	4 ⅞	10	1 ¼
2 ½	2 ½	16	10-5/32	1 ¼	2 ½	2 ½	16	2 ½	5-3/16	10	1 ¼
3 x 2 ½	3	16	9-17/32	1 ¼	3	2 ½	16	2 ½	5 ⅝	10 ½	1 ¼
3 x 2 ½	3	16	10-13/32	1 ¼	3	2 ½	16	2 ½	5-7/16	10 ½	1 ¼
3	3	16	11-19/32	1 ¼	3	3	16	3	5-29/32	11 ½	1 ¼
3 ½ x 2 ½	3 ½	16	9-25/32	1 ¼	3 ½	2 ½	16	2 ½	5 ⅜	11	1 ¼
3 ½ x 2 ½	3 ½	16	10-21/32	1 ¼	3 ½	2 ½	16	2 ½	5-11/16	11	1 ¼
3 ½ x 3	3 ½	16	11-27/32	1 ¼	3 ½	3	16	3	6-5/32	13	1 ¼
3 ½	3 ½	16	12-31/32	1 ¼	3 ½	3 ½	16	3 ½	6-9/16	13	1 ¼
4 x 2 ½	4	16	10-1/32	1 ¼	4	2 ½	16	2 ½	5 ⅝	12	1 ¼
4 x 2 ½	4	16	10-29/32	1 ¼	4	2 ½	16	2 ½	5-15/16	12	1 ¼
4 x 3	4	16	12-3/29	1 ¼	4	3	16	3	6-13/32	12	1 ¼
4 x 3 ½	4	16	13-7/32	1 ¼	4	3 ½	16	3 ½	6-13/16	14	1 ¼
4	4	16	14-11/32	1 ¼	4	4	16	4	7 ¼	14	1 ¼
5 x 2 ½	5	16	10-17/32	1 ½	5	2 ½	16	2 ½	6 ⅝	13	1 ¼
5 x 2 ½	5	14	11-13/32	1 ½	5	2 ½	16	2 ½	6-7/16	13	1 ¼
5 x 3	5	14	12-19/32	1 ½	5	3	16	3	6-29/32	15 ½	1 ¼
5 x 3 ½	5	14	13-23/32	1 ½	5	3 ½	16	3 ½	7-5/16	15 ½	1 ¼
5 x 4	5	14	14-27/32	1 ½	5	4	16	4	7 ¾	15 ½	1 ¼
5	5	14	17-9/16	1 ½	5	5	14	5	9	18 ½	1 ½
6 x 2 ½	6	14	11-1/32	1 ½	6	2 ½	16	2 ½	6 ⅝	15	1 ¼
6 x 2 ½	6	14	11-29/32	1 ½	6	2 ½	16	2 ½	6-15/16	15	1 ¼
6 x 3	6	14	13-3/32	1 ½	6	3	16	3	7-13/32	15	1 ¼
6 x 3 ½	6	14	14-7/32	1 ½	6	3 ½	16	3 ½	7-13/16	17	1 ¼
6 x 4	6	14	15-11/32	1 ½	6	4	16	4	8 ¼	17	1 ¼
6 x 5	6	14	18-1/16	1 ½	6	5	14	5	9 ½	21	1 ½
6	6	14	20-25/32	1 ½	6	6	14	6	10-25/32	21	1 ½

TUBE & PIPE

Vacuum Bends

Standard 45° Y's

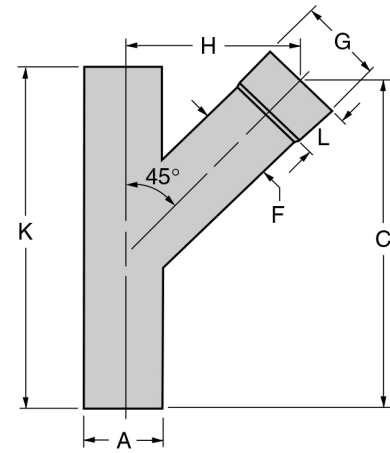

SIZE (IN.)	A-O.D. (IN.)	GAUGE	C (IN.)	F-O.D. (IN.)	GAUGE	G-I.D. (IN.)	H (IN.)	K (IN.)	L (IN.)
8 x 2 1/8	8	14	12-1/32	2 1/8	16	2 1/8	7 5/8	18	1 1/4
8 x 2 1/2	8	14	12-29/32	2 1/2	16	2 1/2	7-15/16	18	1 1/4
8 x 3	8	14	14-3/32	3	16	3	8-13/32	18	1 1/4
8 x 3 1/2	8	14	15-7/32	3 1/2	16	3 1/2	8-13/16	21	1 1/4
8 x 4	8	14	16-11/32	4	16	4	9 1/4	21	1 1/4
8 x 5	8	14	19-1/16	5	14	5	10 1/2	24	1 1/2
8 x 6	8	14	21-25/32	6	14	6	11-25/32	24	1 1/2
8	8	14	27	8	14	8	14-5/32	29	-
10 x 2 1/8	10	+	13-1/32	2 1/8	16	2 1/8	8 5/8	21	1 1/4
10 x 2 1/2	10	+	13-29/32	2 1/2	16	2 1/2	8-15/16	21	1 1/4
10 x 3	10	+	15-3/32	3	16	3	9-13/32	21	1 1/4
10 x 3 1/2	10	+	16-7/32	3 1/2	16	3 1/2	9-13/16	24	1 1/4
10 x 4	10	+	17-11/32	4	16	4	10 1/4	24	1 1/4
10 x 5	10	+	20-1/16	5	14	5	11 1/2	24	1 1/2
10 x 6	10	+	22 3/4	6	14	6	12-25/32	28	1 1/2
10 x 8	10	+	28	8	14	-	15-5/32	32	-
10	10	+	34-11/16	10	12	-	18 5/8	36	-
12 x 2 1/8	12	+	14-1/32	3 1/2	16	2 1/8	9 5/8	24	1 1/4
12 x 2 1/2	12	+	14-29/32	4	16	2 1/2	9-31/32	24	1 1/4
12 x 3	12	+	16-3/32	5	14	3	10-13/32	24	1 1/2
12 x 3 1/2	12	+	17-7/32	2 1/8	16	3 1/2	10-13/16	27	1 1/4
12 x 4	12	+	18-11/32	2 1/2	16	4	11 1/4	27	1 1/4
12 x 5	12	+	21-1/16	3	16	5	12 1/2	27	1 1/2
12 x 6	12	+	23 3/4	3 1/2	16	6	13-25/32	31	1 1/2
12 x 8	12	+	29	4	16	-	16-5/32	35	-
12 x 10	12	+	35-11/16	5	14	-	19 5/8	39	-
12	12	+	40 3/4	6	14	-	21-27/32	43	-

When ordering, specify type of material: Carbon Steel, Zinc Galv. Coated Steel, Stainless Steel, Aluminum. Bell or Straight Ends – 2 1/8" through 6". Straight ends only – 8" and up. + Consult factory

CAMCORP

A MEMBER OF THE SCHEUCH GROUP

ALL STATED SPECIFICATIONS ARE SUBJECT TO CHANGE WITHOUT NOTICE OR OBLIGATION. VISIT CAMCORPINC.COM FOR THE LATEST INFORMATION.

standard45Y 07/19 ©CAMCORP, INC.