

WEIGHTED RELIEF VALVES



Description

A weighted relief valve (WRV) protects your blower package by allowing excess air pressure to relieve at a predetermined set point. This design is very efficient, consistent and it will provide years of maintenance free operation. The weighted relief valve is easily installed in the vertical position on the discharge side of the silencer. The valve body is available in 2", 3", or 4" NPT connection sizes. The set point is controlled by removable weights which are available in either 0.5 PSI or 1.0 PSI increments.

Pressure models have standard male NPT connections. Available from 1 PSIG through 29 PSIG with a calibrated 0.5 PSIG increment per removable disc.

Vacuum canisters have standard female NPT connections. Available from 2" Hg through 30" Hg with a calibrated 1" Hg increment per removable disc.

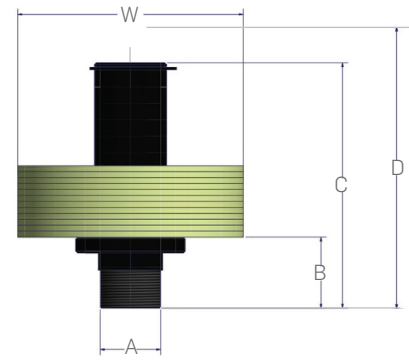

VALVE ASSEMBLY				
PART NUMBER	NPT A	DIM B	DIM C	DIM D
2WRV	2"	2.31	7.81	9.25
3WRV	3"	3.18	8.70	9.75
4WRV	4"	3.34	9.83	10.5

WEIGHTS	
PART NUMBER	DIAMETER W
2W05PSI	6.75
2W1PSI	9.12
3W05PSI	10.50
3W1PSI	14.37
4W05PSI	13.50
4W1PSI	18.50